

EXHIBIT 1



Contract Number: BF-20246516

TRAIL CONSTRUCTION AND MAINTENANCE AGREEMENT

BNSF File No.: BF-20246516
Mile Post 7.68
Line Segment 235
U.S. DOT Number 980785P
Lakes Subdivision

This Agreement (“**Agreement**”), is executed to be effective as of _____, _____ (“**Effective Date**”), by and between **BNSF RAILWAY COMPANY**, a Delaware corporation (“**BNSF**”) and the **City of Duluth**, a political subdivision of the State of Minnesota (“**Agency**”).

RECITALS

WHEREAS, BNSF owns and operates a line of railroad in and through the City of Duluth, State of Minnesota;

within the existing easement granted to the city of Duluth on November 15th, 1982

WHEREAS, in the interest of aiding public safety, the Agency is undertaking a project to relocate the existing trail crossing, located at BNSF Line Segment **235** and Milepost **7.68**, and designated by D.O.T. No. 980785P, by reconstructing the trail to pass within the existing easement across the BNSF right-of-way granted to the city of Duluth on November 15th, 1982 as indicated on the plans in Exhibit A, attached hereto and incorporated herein; and

WHEREAS, the Agency also desires BNSF to install a new crossing surface for the trail with a new concrete and rubber crossing surface; and

WHEREAS, the Agency is paying for the acquisition and installation of the new crossing surface; and

WHEREAS, the BNSF agrees to purchase and install, at AGENCY’S sole expense, the new crossing surface described in the scope of work herein, and upon the terms and conditions set forth below; and

WHEREAS, the Agency agrees to purchase and enter into a trail permit with BNSF, further outlined in Exhibit E; and



Contract Number: BF-20246516

NOW, THEREFORE, in consideration of the mutual covenants and agreements of the parties contained herein, the receipt and sufficiency of which are hereby acknowledged, the parties agree as follows:

ARTICLE I – SCOPE OF WORK

- 1) The term "**Project**" as used herein includes any and all work related to the trail construction by Agency and installation of new crossing surfaces at U.S. D.O.T No. 980785P, (hereinafter referred to as the "**Crossing**") by BNSF, more particularly described on the Exhibit A, including, but not limited to, any and all changes to telephone, telegraph, signal and electrical lines and appurtenances, temporary and permanent track work, fencing, grading, alterations to or new construction of drainage facilities, preliminary and construction engineering and contract preparation.

ARTICLE II – RAILROAD OBLIGATIONS

In consideration of the covenants of Agency set forth herein and the faithful performance thereof, BNSF agrees as follows:

- 1) BNSF will furnish all labor, materials, tools, and equipment for railroad work required for the construction of the Project, such railroad work and the estimated cost thereof being as shown on Exhibit D attached hereto and made a part hereof. In the event construction on the Project has not commenced within six (6) months following the Effective Date, BNSF may, in its sole and absolute discretion, revise the cost estimates set forth in said Exhibit D. In such event, the revised cost estimates will become a part of this Agreement as though originally set forth herein. Any item of work incidental to the items listed on Exhibit D not specifically mentioned therein may be included as a part of this Agreement upon written approval of Agency, which approval will not be unreasonably withheld. Construction of the Project must include the following railroad work by BNSF:
 - A. Procurement of materials, equipment and supplies necessary for the railroad work;
 - B. Preliminary engineering, design, and contract preparation;
 - C. Furnishing of flagging services during construction of the Project as required and set forth in further detail on Exhibit C, attached to this Agreement and made a part hereof;



Contract Number: BF-20246516

- D. Furnishing engineering and inspection as required in connection with the construction of the Project;
 - E. Removal and disposal of the existing crossing surfaces from the Crossing
 - F. Installation of two 16-foot concrete crossing surfaces for the two tracks complete with new rail, ties, ballast, fasteners, along with appropriate surfacing, to carry the improved roadway and sidewalks
 - G. Make such changes in the alignment, location and elevation of its telephone, telegraph, signal and/or wire lines and appurtenances along, over or under the tracks, both temporary and permanent, as may become necessary by reason of the construction of the Project.
- 2) BNSF will do all railroad work set forth in Article II, Section 2 above on an **actual cost** basis, when BNSF, in its sole discretion, determines it is required by its labor agreements to perform such work with its own employees working under applicable collective bargaining agreements.
 - 3) Agency agrees to reimburse BNSF for work of an emergency nature caused by Agency or Agency's contractor in connection with the Project which BNSF deems is reasonably necessary for the immediate restoration of railroad operations, or for the protection of persons or BNSF property. Such work may be performed by BNSF without prior approval of Agency and Agency agrees to fully reimburse BNSF for all such emergency work.
 - 4) BNSF may charge Agency for insurance expenses, including self-insurance expenses, when such expenses cover the cost of Employer's Liability (including, without limitation, liability under the Federal Employer's Liability Act) in connection with the construction of the Project. Such charges will be considered part of the actual cost of the Project, regardless of the nature or amount of ultimate liability for injury, loss or death to BNSF's employees, if any.
 - 5) During the construction of the Project, BNSF will send Agency progressive invoices detailing the costs of the railroad work performed by BNSF under this Agreement. Agency must reimburse BNSF for completed force-account work within thirty (30) days of the date of the invoice for such work. Upon completion of the Project, BNSF will send Agency a detailed invoice of final costs, segregated as to labor and materials for each item in the recapitulation shown on Exhibit D. Pursuant to this section and Article IV, Section 7 herein, Agency must pay the final invoice within



Contract Number: BF-20246516

ninety (90) days of the date of the final invoice. BNSF will assess a finance charge of .033% per day (12% per annum) on any unpaid sums or other charges due under this Agreement which are past its credit terms. The finance charge continues to accrue daily until the date payment is received by BNSF, not the date payment is made or the date postmarked on the payment. Finance charges will be assessed on delinquent sums and other charges as of the end of the month and will be reduced by amounts in dispute and any unposted payments received by the month's end. Finance charges will be noted on invoices sent to Agency under this section.

ARTICLE III – AGENCY OBLIGATIONS

In consideration of the covenants of BNSF set forth herein and the faithful performance thereof, Agency agrees as follows:

- 1)** Agency must furnish to BNSF plans and specifications for the Project. Said plans (reduced size 11" x 17"), showing the plan and profile of the roadway work on BNSF right-of-way and marked as Exhibit A, attached hereto and made a part hereof, must be submitted to BNSF for the development of railroad cost estimates.
- 2)** Agency must make any required application and obtain all required permits, including the trail permit marked as Exhibit E, and approvals for the construction of the Project.
- 3)** Agency must acquire all rights of way necessary for the construction of the Project.
- 4)** Agency must make any and all arrangements, in compliance with BNSF's Utility Accommodation Manual (<http://www.bnsf.com/communities/faqs/pdf/utility.pdf>), for the installation or relocation of wire lines, pipe lines and other facilities owned by private persons, companies, corporations, political subdivisions or public utilities other than BNSF which may be necessary for the construction of the Project.
- 5)** Agency must construct the Project as shown on the attached Exhibit A and do all work ("Agency's Work") provided for in the plans and specifications for the Project, except railroad work that will be performed by BNSF hereunder. Agency must furnish all labor, materials, tools and equipment for the performance of Agency's Work. The principal elements of Agency's Work are as follows:
 - A.** Design and Reconstruction/Construction of the trail;
 - B.** Installation of a pavement marking stop bar in accordance with the Manual on Uniform Traffic Control Devices (hereinafter called, "MUTCD");



Contract Number: BF-20246516

- C. Installation of advance warning signs in accordance with the MUTCD
 - D. Perform all necessary grading and paving, including backfill of excavations and restoration of disturbed vegetation on BNSF's right-of-way;
 - E. Provide suitable drainage, both temporary and permanent;
 - F. Provide all barricades, lights, flagmen or traffic control devices necessary for preventing vehicular traffic from using a portion of the Crossing, during the installation of the concrete crossing surfaces, and also during the installation of the Crossing Signal Equipment.
 - G. Construct asphalt/concrete trail surface on approaches to each track. Trail surface will match elevation of the Main (and Siding) Track crossing surface(s) and remain level to a point at least thirty (30) feet from nearest rail. Any concrete headers will be constructed no closer than 5'-6" (preferably 6'-0") from centerline of each track to provide for a minimum of 11'-0" (preferably 12'-0") opening for track and railroad crossing surface;
 - H. Provide and place six (6) to twelve (12) inch wide section of asphalt between roadway concrete headers (and sidewalks) and the new concrete crossing surfaces, including that portion of the trail located between the Main Track and Siding Track.
 - I. Job site cleanup including removal of all construction materials, concrete debris, surplus soil, refuse, contaminated soils, asphalt debris, litter and other waste materials to the satisfaction of BNSF;
- 6) The Agency must have advanced railroad crossing signs and standard pavement markings in place at the crossing shown on Exhibit A (if the same are required by the MUTCD) prior to the acceptance of this Project by the Agency.
- 7) The Agency must give BNSF's Manager Public Projects written notice to proceed ("**Notice to Proceed**") with the railroad portion of the work after receipt of necessary funds for the Project. BNSF will not begin the railroad work (including, without limitation, procurement of supplies, equipment or materials) until written Notice to Proceed is received from Agency.
- 8) The Agency's Work must be performed by Agency or Agency's contractor in a manner that will not endanger or interfere with the safe and timely operations of BNSF and its facilities.



Contract Number: BF-20246516

- 9) For any future inspection or maintenance, either routine or otherwise, performed by subcontractors on behalf of the Agency, Agency shall require the subcontractors to comply with the provisions of the attached Exhibit C and execute the agreement attached hereto as Exhibit C-1. Prior to performing any future maintenance with its own personnel, Agency shall: comply with all of BNSF's applicable safety rules and regulations; require any Agency employee performing maintenance to complete the safety training program at the BNSF's Internet Website "www.contractororientation.com"; notify BNSF when, pursuant to the requirements of Exhibit C, a flagger is required to be present; procure, and have approved by BNSF's Risk Management Department, Railroad Protective Liability insurance.
- 10) Agency must require its contractor(s) to notify BNSF's Roadmaster at least thirty (30) calendar days prior to requesting a BNSF flagman in accordance with the requirements of Exhibit C attached hereto. Additionally, Agency must require its contractor(s) to notify BNSF's Manager of Public Projects thirty (30) calendar days prior to commencing work on BNSF property or near BNSF tracks.
- 11) Agency must include the following provisions in any contract with its contractor(s) performing work on said Project:
 - A. The Contractor is placed on notice that fiber optic, communication and other cable lines and systems (collectively, the "Lines") owned by various telecommunications companies may be buried on BNSF's property or right-of-way. The locations of these Lines have been included on the plans based on information from the telecommunications companies. The contractor will be responsible for contacting BNSF and the telecommunications companies and notifying them of any work that may damage these Lines or facilities and/or interfere with their service. The contractor must also mark all Lines shown on the plans or marked in the field in order to verify their locations. The contractor must also use all reasonable methods when working in the BNSF right-of-way or on BNSF property to determine if any other Lines (fiber optic, cable, communication or otherwise) may exist.
 - B. Failure to mark or identify these Lines will be sufficient cause for BNSF's engineering representative Steve Muellner at 715-394-1235 to stop construction at no cost to the Agency or BNSF until these items are completed.
 - C. The Contractor will be responsible for the rearrangement of any facilities or Lines determined to interfere with the construction. The Contractor must cooperate fully with any telecommunications company(ies) in performing such rearrangements.



Contract Number: BF-20246516

D. In addition to the liability terms contained elsewhere in this Agreement, the contractor hereby indemnifies, defends and holds harmless BNSF for, from and against all cost, liability, and expense whatsoever (including, without limitation, attorney's fees and court costs and expenses) arising out of or in any way contributed to by any act or omission of Contractor, its subcontractors, agents and/or employees that cause or in any way or degree contribute to (1) any damage to or destruction of any Lines by Contractor, and/or its subcontractors, agents and/or employees, on BNSF's property or within BNSF's right-of-way, (2) any injury to or death of any person employed by or on behalf of any telecommunications company, and/or its contractor, agents and/or employees, on BNSF's property or within BNSF's right-of-way, and/or (3) any claim or cause of action for alleged loss of profits or revenue by, or loss of service by a customer or user of such telecommunication company(ies). **THE LIABILITY ASSUMED BY CONTRACTOR WILL NOT BE AFFECTED BY THE FACT, IF IT IS A FACT, THAT THE DAMAGE, DESTRUCTION, INJURY, DEATH, CAUSE OF ACTION OR CLAIM WAS OCCASIONED BY OR CONTRIBUTED TO BY THE NEGLIGENCE OF BNSF, ITS AGENTS, SERVANTS, EMPLOYEES OR OTHERWISE, EXCEPT TO THE EXTENT THAT SUCH CLAIMS ARE PROXIMATELY CAUSED BY THE INTENTIONAL MISCONDUCT OR GROSS NEGLIGENCE OF BNSF.**

13) Agency must require compliance with the obligations set forth in this agreement, including Exhibit C and Exhibit C-1, and incorporate in each prime contract for construction of the Project, or the specifications therefor (i) the provisions set forth in Article III and IV; and (ii) the provisions set forth in Exhibit C and Exhibit C-1, attached hereto and by reference made a part hereof.

14) Except as otherwise provided below in this Section 13, all construction work performed hereunder by Agency for the Project will be pursuant to a contract or contracts to be let by Agency, and all such contracts must include the following:

A. All work performed under such contract or contracts within the limits of BNSF's right-of-way must be performed in a good and workmanlike manner in accordance with plans and specifications approved by BNSF;

B. Changes or modifications during construction that affect safety or BNSF operations must be subject to BNSF's approval;

C. No work will be commenced within BNSF's right-of-way until each of the prime contractors employed in connection with said work must have (i) executed and delivered to BNSF an agreement in the form of Exhibit C-1, and (ii) delivered to and secured BNSF's approval of the required insurance; and



Contract Number: BF-20246516

- D. If it is in Agency's best interest, Agency may direct that the construction of the Project be done by day labor under the direction and control of Agency, or if at any time, in the opinion of Agency, the contractor has failed to prosecute with diligence the work specified in and by the terms of said contract, Agency may terminate its contract with the contractor and take control over the work and proceed to complete the same by day labor or by employing another contractor(s) provided; however, that any contractor(s) replacing the original contractor(s) must comply with the obligations in favor of BNSF set forth above and, provided further, that if such construction is performed by day labor, Agency will, at its expense, procure and maintain on behalf of BNSF the insurance required by Exhibit C-1.
- E. To facilitate scheduling for the Project, Agency shall have its contractor give BNSF's Roadmaster 30 days advance notice of the proposed times and dates for work windows. BNSF and Agency's contractor will establish mutually agreeable work windows for the Project. BNSF has the right at any time to revise or change the work windows, due to train operations or service obligations. BNSF will not be responsible for any additional costs and expenses resulting from a change in work windows. Additional costs and expenses resulting from a change in work windows shall be accounted for in the contractor's expenses for the Project.
- 15) Agency must advise the appropriate BNSF Manager Public Projects, in writing, of the completion date of the Project within thirty (30) days after such completion date. Additionally, Agency must notify BNSF's Manager Public Projects, in writing, of the date on which Agency and/or its Contractor will meet with BNSF for the purpose of making final inspection of the Project.
- 16) **TO THE FULLEST EXTENT PERMITTED BY LAW, AGENCY HEREBY RELEASES, INDEMNIFIES, DEFENDS AND HOLDS HARMLESS BNSF, ITS AFFILIATED COMPANIES, PARTNERS, SUCCESSORS, ASSIGNS, LEGAL REPRESENTATIVES, OFFICERS, DIRECTORS, SHAREHOLDERS, EMPLOYEES AND AGENTS FOR, FROM AND AGAINST ANY AND ALL CLAIMS, LIABILITIES, FINES, PENALTIES, COSTS, DAMAGES, LOSSES, LIENS, CAUSES OF ACTION, SUITS, DEMANDS, JUDGMENTS AND EXPENSES (INCLUDING, WITHOUT LIMITATION, COURT COSTS AND ATTORNEYS' FEES) OF ANY NATURE, KIND OR DESCRIPTION OF ANY PERSON (INCLUDING, WITHOUT LIMITATION, THE EMPLOYEES OF THE PARTIES HERETO) OR ENTITY DIRECTLY OR INDIRECTLY ARISING OUT OF, RESULTING FROM OR RELATED TO (IN WHOLE OR IN PART) (I) THE USE, OCCUPANCY OR PRESENCE OF AGENCY, ITS CONTRACTORS, SUBCONTRACTORS, EMPLOYEES OR AGENTS IN, ON, OR ABOUT THE CONSTRUCTION SITE, (II) THE PERFORMANCE, OR FAILURE TO**



Contract Number: BF-20246516

PERFORM BY THE AGENCY, ITS CONTRACTORS, SUBCONTRACTORS, EMPLOYEES, OR AGENTS, ITS WORK OR ANY OBLIGATION UNDER THIS AGREEMENT, (III) THE SOLE OR CONTRIBUTING ACTS OR OMISSIONS OF AGENCY, ITS CONTRACTORS, SUBCONTRACTORS, EMPLOYEES, OR AGENTS IN, ON, OR ABOUT THE CONSTRUCTION SITE, (IV) AGENCY'S BREACH OF THE TEMPORARY CONSTRUCTION LICENSE OR EASEMENT GRANTED TO AGENCY PURSUANT TO ARTICLE II OF THIS AGREEMENT, (V) ANY RIGHTS OR INTERESTS GRANTED TO AGENCY PURSUANT TO THE TEMPORARY CONSTRUCTION LICENSE OR EASEMENT DISCUSSED IN ARTICLE II OF THIS AGREEMENT, (VI) AGENCY'S OCCUPATION AND USE OF BNSF'S PROPERTY OR RIGHT-OF-WAY, INCLUDING, WITHOUT LIMITATION, SUBSEQUENT MAINTENANCE OF THE STRUCTURE BY AGENCY, OR (VII) AN ACT OR OMISSION OF AGENCY OR ITS OFFICERS, AGENTS, INVITEES, EMPLOYEES OR CONTRACTORS OR ANYONE DIRECTLY OR INDIRECTLY EMPLOYED BY ANY OF THEM, OR ANYONE THEY CONTROL OR EXERCISE CONTROL OVER. THE LIABILITY ASSUMED BY AGENCY WILL NOT BE AFFECTED BY THE FACT, IF IT IS A FACT, THAT THE DAMAGE, DESTRUCTION, INJURY OR DEATH WAS OCCASIONED BY OR CONTRIBUTED TO BY THE NEGLIGENCE OF BNSF, ITS AGENTS, SERVANTS, EMPLOYEES OR OTHERWISE, EXCEPT TO THE EXTENT THAT SUCH CLAIMS ARE PROXIMATELY CAUSED BY THE INTENTIONAL MISCONDUCT OR GROSS NEGLIGENCE OF BNSF.

ARTICLE IV – JOINT OBLIGATIONS

IN CONSIDERATION of the premises, the parties hereto mutually agree to the following:

- 1) All work contemplated in this Agreement must be performed in a good and workmanlike manner and each portion must be promptly commenced by the party obligated hereunder to perform the same and thereafter diligently prosecuted to conclusion in its logical order and sequence. Furthermore, any changes or modifications during construction which affect BNSF will be subject to BNSF's approval prior to the commencement of any such changes or modifications.
- 2) The work hereunder must be done in accordance with the Exhibit A and the detailed plans and specifications approved by BNSF.
- 3) Agency must require its contractor(s) to reasonably adhere to the Project's construction schedule for all Project work. The parties hereto mutually agree that BNSF's failure to complete the railroad work in accordance with the construction



Contract Number: BF-20246516

schedule due to inclement weather or unforeseen railroad emergencies will not constitute a breach of this Agreement by BNSF and will not subject BNSF to any liability. Regardless of the requirements of the construction schedule, BNSF reserves the right to reallocate the labor forces assigned to complete the railroad work in the event of an emergency to provide for the immediate restoration of railroad operations of either BNSF or its related railroads, or to protect persons or property on or near any BNSF owned property. BNSF will not be liable for any additional costs or expenses resulting from any such reallocation of its labor forces. The parties mutually agree that any reallocation of labor forces by BNSF pursuant to this provision and any direct or indirect consequences or costs resulting from any such reallocation will not constitute a breach of this Agreement by BNSF.

- 4) BNSF will have the right to stop construction work on the Project if any of the following events take place: (i) Agency (or any of its contractors) performs the Project work in a manner contrary to the plans and specifications approved by BNSF; (ii) Agency (or any of its contractors), in BNSF's opinion, prosecutes the Project work in a manner that is hazardous to BNSF property, facilities or the safe and expeditious movement of railroad traffic; (iii) the insurance described in the attached Exhibit C-1 is canceled during the course of the Project; or (iv) Agency fails to pay BNSF for the Temporary Construction License or the Easement pursuant to Article II, Section 1 of this Agreement. The work stoppage will continue until all necessary actions are taken by Agency or its contractor to rectify the situation to the satisfaction of BNSF's Division Engineer or until proof of additional insurance has been delivered to and accepted by BNSF. In the event of a breach of (i) this Agreement, (ii) the Temporary Construction License, or (iii) the Easement, BNSF may immediately terminate the Temporary Construction License or the Easement. Any such work stoppage under this provision will not give rise to any liability on the part of BNSF. BNSF's right to stop the work is in addition to any other rights BNSF may have including, but not limited to, actions or suits for damages or lost profits. In the event that BNSF desires to stop construction work on the Project, BNSF agrees to immediately notify the following individual in writing:

City of Duluth Director Public Works and Utilities
411 W. First Street, Room 211B
Duluth, MN 55802
jbenning@duluthmn.gov, (218) 730-5105

- 5) Agency must supervise and inspect the operations of all Agency contractors to ensure compliance with the plans and specifications approved by BNSF, the terms of this Agreement and all safety requirements of BNSF. If BNSF determines that proper supervision and inspection are not being performed by Agency personnel at any time



Contract Number: BF-20246516

during construction of the Project, BNSF has the right to stop construction (within or adjacent to its operating right-of-way). Construction of the Project will not proceed until Agency corrects the situation to BNSF's reasonable satisfaction. If BNSF feels the situation is not being corrected in an expeditious manner, BNSF will immediately notify the City of Duluth Director Public Works and Utilities (Jbenning@duluthmn.gov, (218) 730-5105) for appropriate corrective action.

- 6) Pursuant to this section and Article II, Section 6 herein, Agency must reimburse BNSF in full for the **actual costs** of all work performed by BNSF under this Agreement (including taxes, such as applicable sales and use taxes, business and occupation taxes, and similar taxes), as set forth in Article IV, Section 6 herein. BNSF's Share must be paid upon completion of the Project.
- 7) All expenses detailed in statements sent to Agency pursuant to Article II, Section 6 herein will comply with the terms and provisions of the Title 23 U.S. Code, Title 23 Code of Federal Regulations, and the Federal-Aid Policy Guide, U.S. Department of Transportation, as amended from time to time, which manual is hereby incorporated into and made a part of this Agreement by reference. The parties mutually agree that BNSF's preliminary engineering, design, and contract preparation costs described in Article II, Section 2 herein are part of the costs of the Project even though such work may have preceded the date of this Agreement.
- 8) The construction of the Project will not commence until Agency gives BNSF's Manager Public Projects thirty (30) days prior written notice of such commencement. The commencement notice will reference BNSF's file number and D.O.T. Crossing No. and must state the time that construction activities will begin.
- 9) In addition to the terms and conditions set forth elsewhere in this Agreement, BNSF and the Agency agree to the following terms upon completion of construction of the Project:
 - A. Agency will own and be fully responsible for repairs, maintenance, future construction or reconstruction of the trail crossing, including the portion of roadway located between the tracks.
 - B. Agency will maintain the elevation of the trail approaches to match the elevation on the railroad track crossing surfaces and to be no more than three (3) inches above or six (6) inches below top-of-rail elevation at a distance measured thirty (30) feet from the nearest rail.



Contract Number: BF-20246516

- C. Agency will maintain the advanced railroad crossing warning signs and pavement markings and agrees to hold harmless and indemnify BNSF for any claims, damages or losses, in whole or in part, caused by or due to the Agency's failure to maintain the advanced warning signs and markings or other requirements of the MUTCD.
 - D. Agency will do nothing and permit nothing to be done in the maintenance of the trail crossing, which will interfere with or endanger facilities of BNSF.
 - E. It is expressly understood by Agency and BNSF that any right to install utilities will be governed by a separate permit or license agreement between the parties hereto.
 - F. BNSF will operate and maintain the new crossing surface in proper condition. Agency must reimburse BNSF for the costs of maintaining the new crossing surface within thirty (30) days of the date of any invoice for such costs. In the event the Agency fails to reimburse BNSF pursuant to this provision, finance charges will be added on any unpaid amounts pursuant to Article II, Section 6 above.
 - G. Notwithstanding the preceding provision, if any regulations, ordinances, acts, rules or other laws subsequently passed or amended by the Agency or any other governmental or legislative authority increase the Agency's portion of maintenance cost under this Agreement, BNSF will receive the benefit of any such regulations, ordinances, acts, rules or other laws and the Agency's increased portion of maintenance costs will be incorporated into and made a part of this Agreement.
 - H. If a railway or other improvement project necessitates rearrangement, relocation, or alteration of the new crossing surface installed hereunder, the costs for such rearrangement, relocation or alteration will be the responsibility of the party requesting such changes.
- 10) Agency must notify and obtain prior authorization from BNSF's Manager of Public Projects before entering BNSF's right-of-way for **Inspection and Maintenance** purposes and the BNSF Manager of Public Projects will determine if flagging is required. If the construction work hereunder is contracted, Agency must require its prime contractor(s) to comply with the obligations set forth in Exhibit C and Exhibit C-1, as the same may be revised from time to time. Agency will be responsible for its contractor(s) compliance with such obligations.



Contract Number: BF-20246516

- 11) Any books, papers, records and accounts of the parties hereto relating to the work hereunder or the costs or expenses for labor and material connected with the construction will at all reasonable times be open to inspection and audit by the agents and authorized representatives of the parties hereto, as well as the State of Minnesota and the Federal Highway Administration, for a period of one (1) year from the date of the final BNSF invoice under this Agreement.
- 12) The covenants and provisions of this Agreement are binding upon and inure to the benefit of the successors and assigns of the parties hereto. Notwithstanding the preceding sentence, neither party hereto may assign any of its rights or obligations hereunder without the prior written consent of the other party.
- 13) In the event construction of the Project does not commence within 18 months of the Effective Date, this Agreement will become null and void.
- 14) Neither termination nor expiration of this Agreement will release either party from any liability or obligation under this Agreement, whether of indemnity or otherwise, resulting from any acts, omissions or events happening prior to the date of termination or expiration.
- 15) To the maximum extent possible, each provision of this Agreement will be interpreted in such a manner as to be effective and valid under applicable law. If any provision of this Agreement is prohibited by, or held to be invalid under, applicable law, such provision will be ineffective solely to the extent of such prohibition or invalidity and the remainder of the provision will be enforceable.
- 16) This Agreement (including exhibits and other documents, manuals, etc. incorporated herein) is the full and complete agreement between BNSF and Agency with respect to the subject matter herein and supersedes any and all other prior agreements between the parties hereto.
- 17) Any notice provided for herein or concerning this Agreement must be in writing and will be deemed sufficiently given when sent by certified mail, return receipt requested, to the parties at the following addresses:

BNSF:	BNSF's Manager Public Projects <u>80 44th Ave NE</u> <u>Minneapolis, MN 55421</u>
-------	--



Contract Number: BF-20246516

Agency: City of Duluth Director Public Works and Utilities
411 W. First Street, Room 211B
Duluth, MN 55802

SIGNATURE PAGE FOLLOWS



Contract Number: BF-20246516

IN WITNESS WHEREOF, the parties hereto have caused this Agreement to be executed and attested by its duly qualified and authorized officials as of the day and year first above written.

BNSF RAILWAY COMPANY

By: _____

Printed Name: _____

Title: _____

WITNESS:

**AGENCY
City of Duluth**

By: _____

Title: City Attorney _____

Date: _____

By: _____

Title: City Auditor _____

Date: _____

By: _____

Title: Mayor _____

Date: _____



Contract Number: BF-20246516

By: _____

Title: City Clerk _____

Date: _____

WITNESS:



Contract Number: BF-20246516

Exhibit A

CITY OF DULUTH, MINNESOTA

CONSTRUCTION PLANS FOR

ADA IMPROVEMENTS, SIGNING

CROSS CITY TRAIL - PHASE 3 RAIL CROSSING

CITY PROJECT NO. 1510

EXISTING	
	RIGHT OF WAY
	PERMANENT EASEMENT
	PROPERTY LINE
	HORIZONTAL CONTROL POINT
	BENCHMARK
	SURVEY MARKER
	SOIL BORING
	SANITARY SEWER AND MANHOLE
	FORCE MAIN AND LIFT STATION
	SANITARY SEWER SERVICE & CLEANOUT
	WATER MAIN, HYDRANT, VALVE AND MANHOLE
	WATER SERVICE AND CURB STOP BOX
	STORM SEWER, MANHOLE AND CATCH BASIN
	CULVERT AND APRON ENDWALL
	GAS MAIN, VALVE, VENT AND METER
	HANDHOLE
	BURIED FIBER OPTIC CABLE AND MANHOLE
	BURIED PHONE CABLE, PEDESTAL AND MANHOLE
	BURIED TV CABLE, PEDESTAL AND MANHOLE
	BURIED ELECTRIC CABLE, PEDESTAL, MANHOLE, TRANSFORMER AND METER
	OVERHEAD WIRE, POLE AND GUY WIRE
	LIGHT POLE
	TRAFFIC SIGNAL
	STREET NAME SIGN
	SIGN (NON STREET NAME)
	RAILROAD TRACKS
	DECIDUOUS AND CONIFEROUS TREE
	BUSH / SHRUB AND STUMP
	EDGE OF WOODED AREA
	WETLAND
	BUILDING
	FENCE (UNIDENTIFIED)
	BARBED WIRE FENCE
	CHAIN LINK FENCE
	ELECTRIC WIRE FENCE
	WOOD FENCE
	WOVEN WIRE FENCE
	PLATE BEAM GUARDRAIL
	CABLE GUARDRAIL
	POST / BOLLARD
	RETAINING WALL
PROPOSED	
	STREET CENTERLINE
	RIGHT-OF-WAY
	PERMANENT EASEMENT
	TEMPORARY EASEMENT
	CONSTRUCTION LIMITS
	SANITARY SEWER, BULKHEAD AND MANHOLE
	FORCE MAIN
	SANITARY SERVICE AND CLEANOUT
	WATER MAIN, TEE, HYDRANT, BULKHEAD AND VALVE
	WATER VALVE MANHOLE, REDUCER, BEND AND CROSS
	WATER SERVICE AND CURB STOP BOX
	STORM SEWER, MANHOLE AND CATCH BASIN
	CULVERT AND APRON ENDWALL
	DRAIN TILE
	DITCH / SWALE
	RIPRAP
	STREET NAME SIGN
	SIGN (NON STREET NAME)
	RETAINING WALL

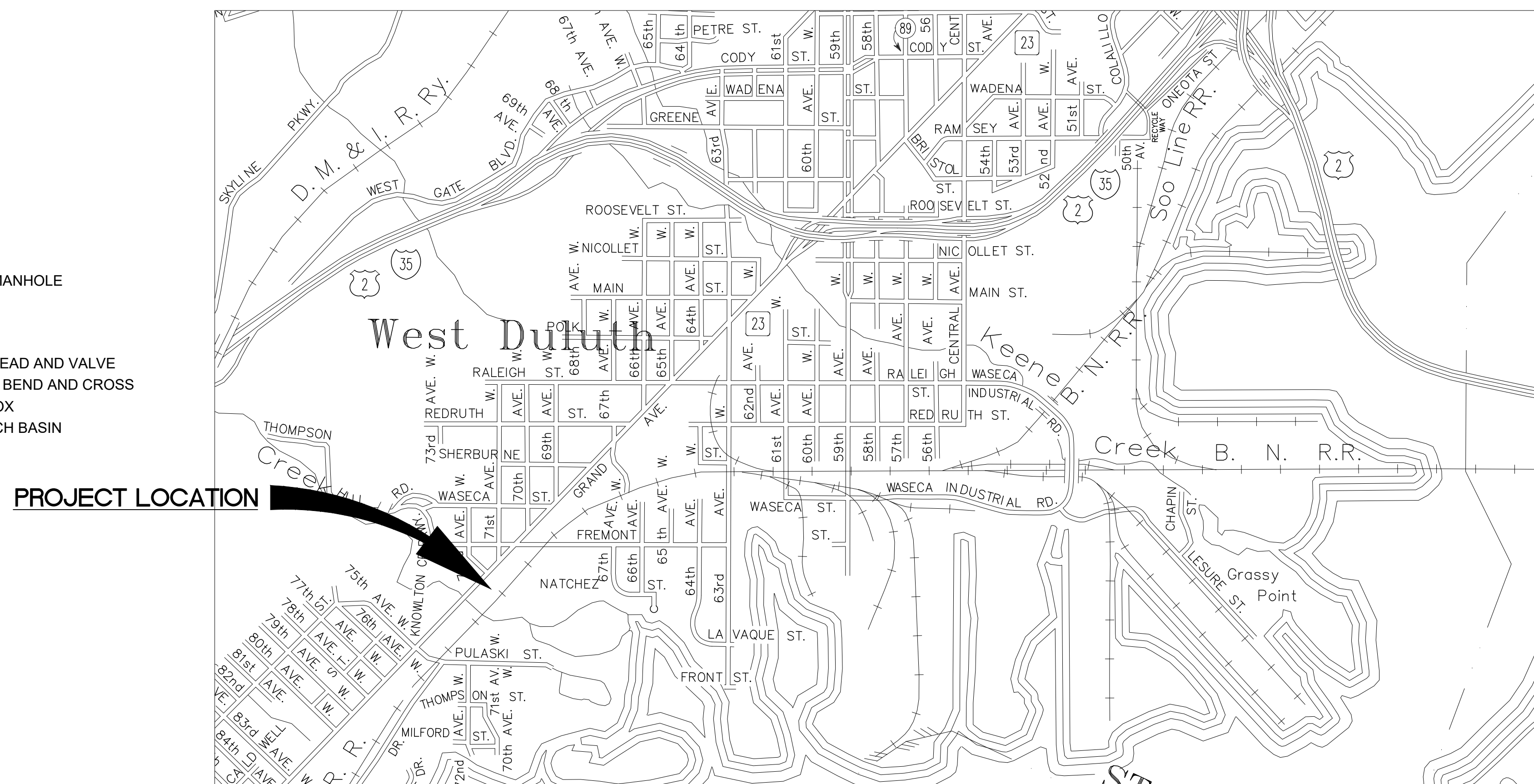

NOTE:
THE SUBSURFACE UTILITY QUALITY INFORMATION IN THIS PLAN IS LEVEL D. THIS UTILITY QUALITY LEVEL WAS DETERMINED ACCORDING TO THE GUIDELINES OF CI/ASCE 38-02 ENTITLED "STANDARD GUIDELINES FOR THE COLLECTION AND DEPICTION OF EXISTING SUBSURFACE UTILITY DATA."

THE CONTRACTOR SHALL CALL THE GOPHER STATE ONE CALL SYSTEM AT 811 BEFORE COMMENCING EXCAVATION.



Know what's below.
Call before you dig.

GOVERNING SPECIFICATIONS
THE 2020 EDITION OF THE MINNESOTA DEPARTMENT OF TRANSPORTATION "STANDARD SPECIFICATIONS FOR CONSTRUCTION" SHALL GOVERN EXCEPT AS MODIFIED BY THE SPECIFICATIONS FOR THIS PROJECT.

ALL TRAFFIC CONTROL DEVICES SHALL CONFORM TO THE LATEST EDITION OF THE MINNESOTA MANUAL ON UNIFORM TRAFFIC CONTROL DEVICES, INCLUDING THE LATEST FIELD MANUAL FOR TEMPORARY TRAFFIC CONTROL ZONE LAYOUTS.

SHEET NO.	DESCRIPTION
1	TITLE SHEET
2	RAIL CROSSING PLAN
3	ADA DETAILS

THIS PLAN CONTAINS 3 SHEETS.

PROJECT LOCATION

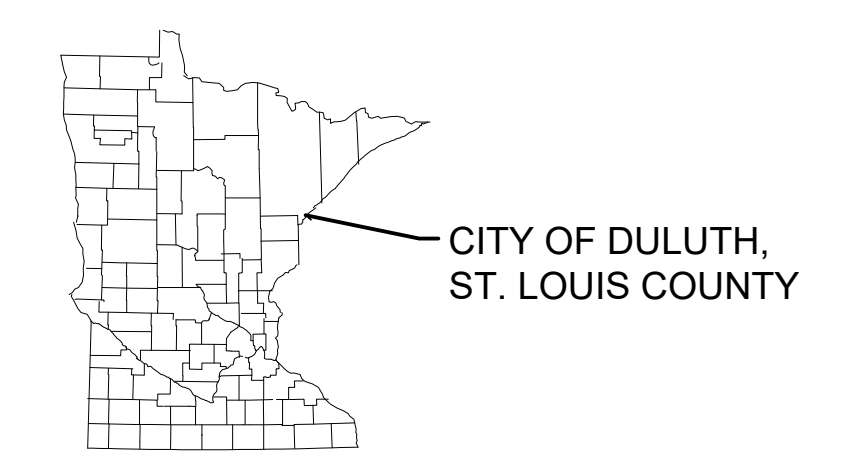

APPROVED:	
CHIEF ENGINEER OF TRANSPORTATION	DATE
APPROVED:	
CITY ENGINEER	DATE

DULUTH, MINNESOTA

SEH
PHONE: 218.279.3000
418 W SUPERIOR ST
STE 200
DULUTH, MN 55802-1512
www.sehinc.com

Signature	PROJECT NO.
Date:	1
Lic. No.	of 3

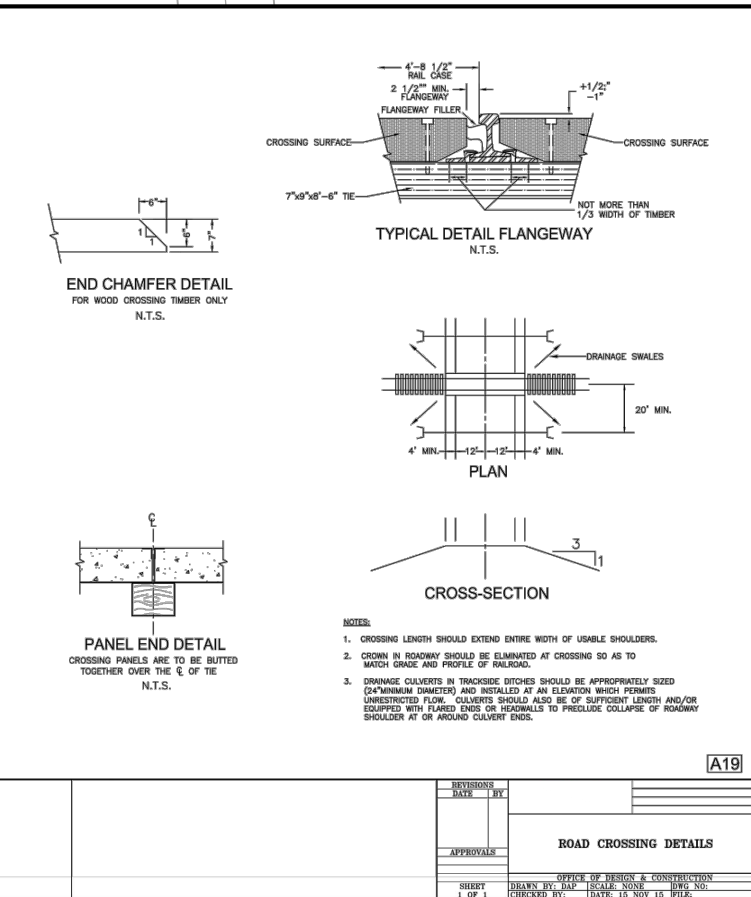
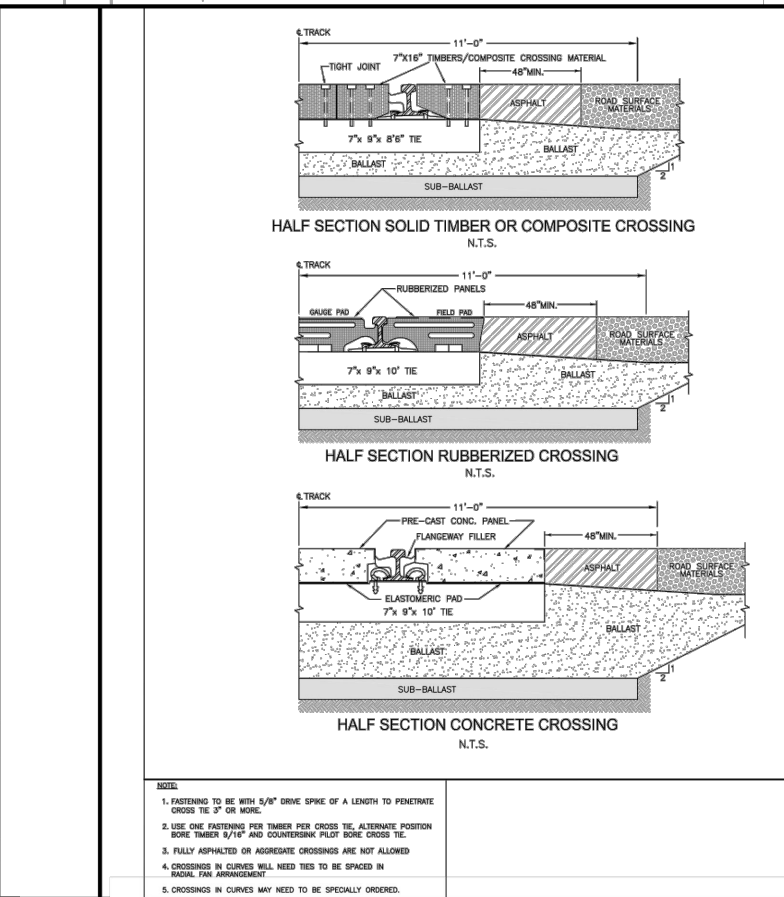
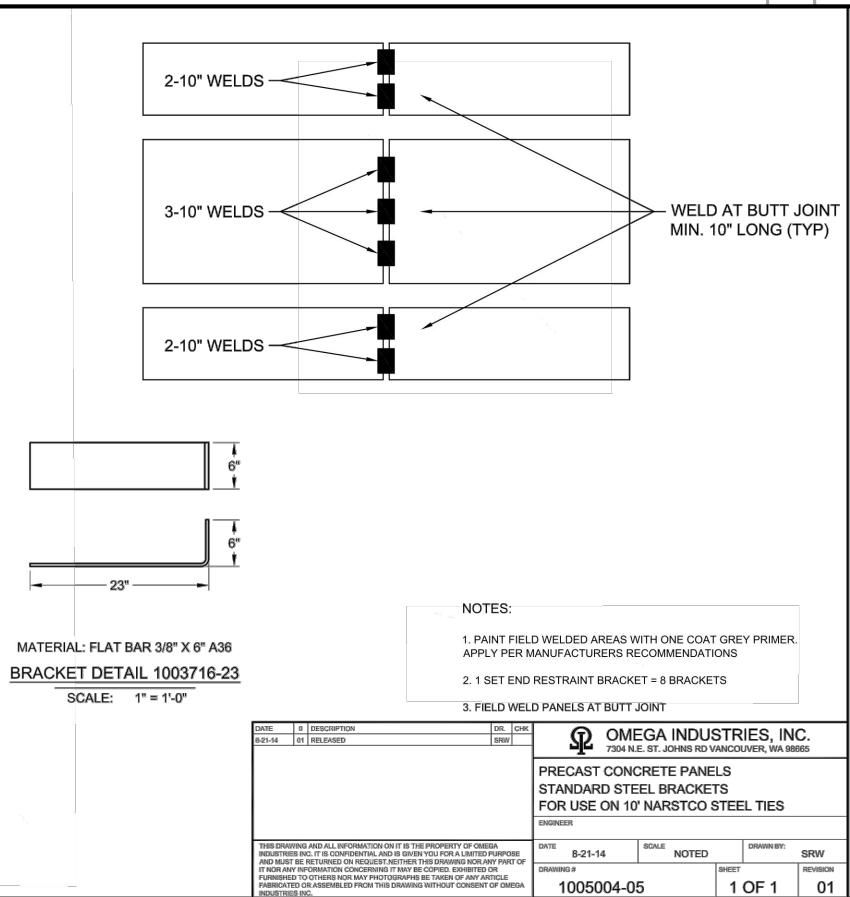
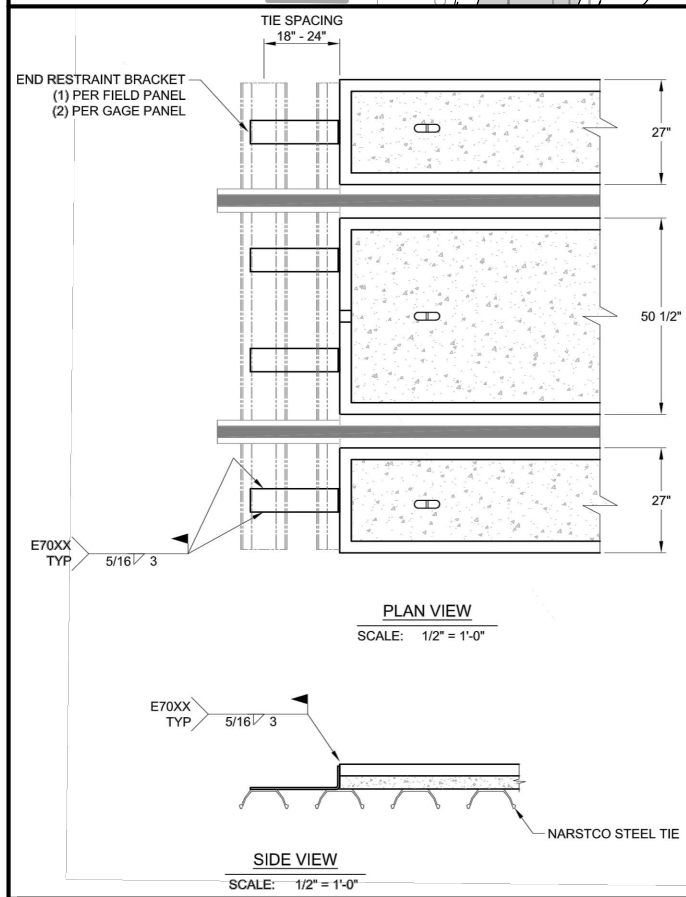
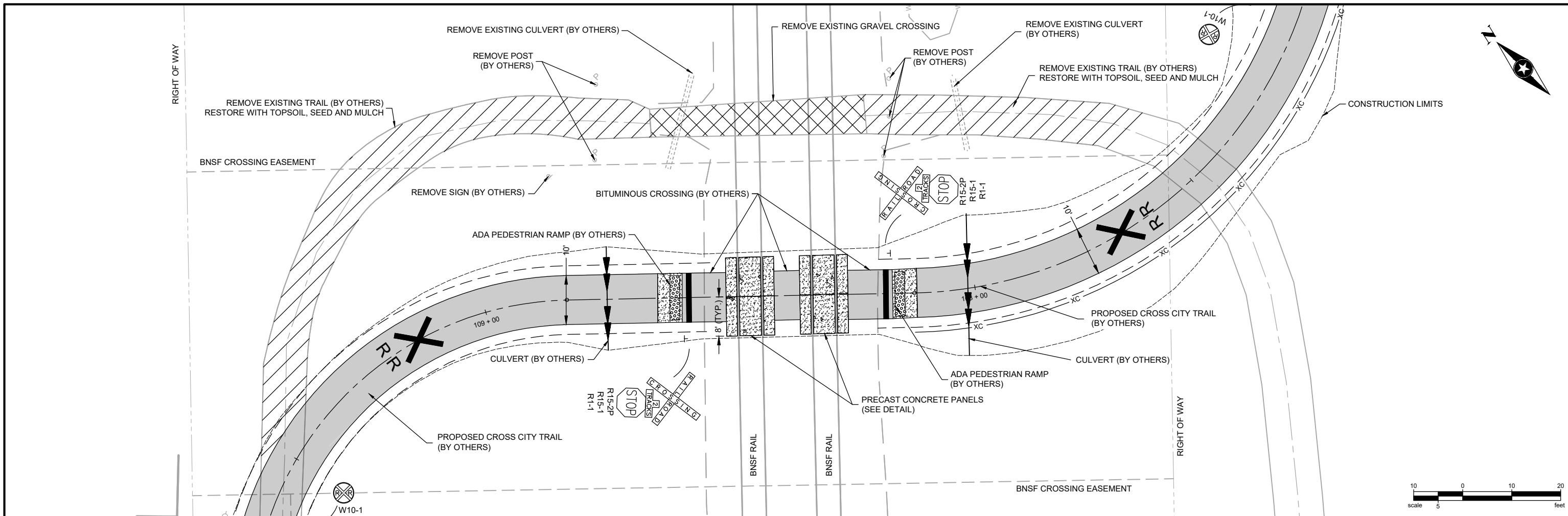

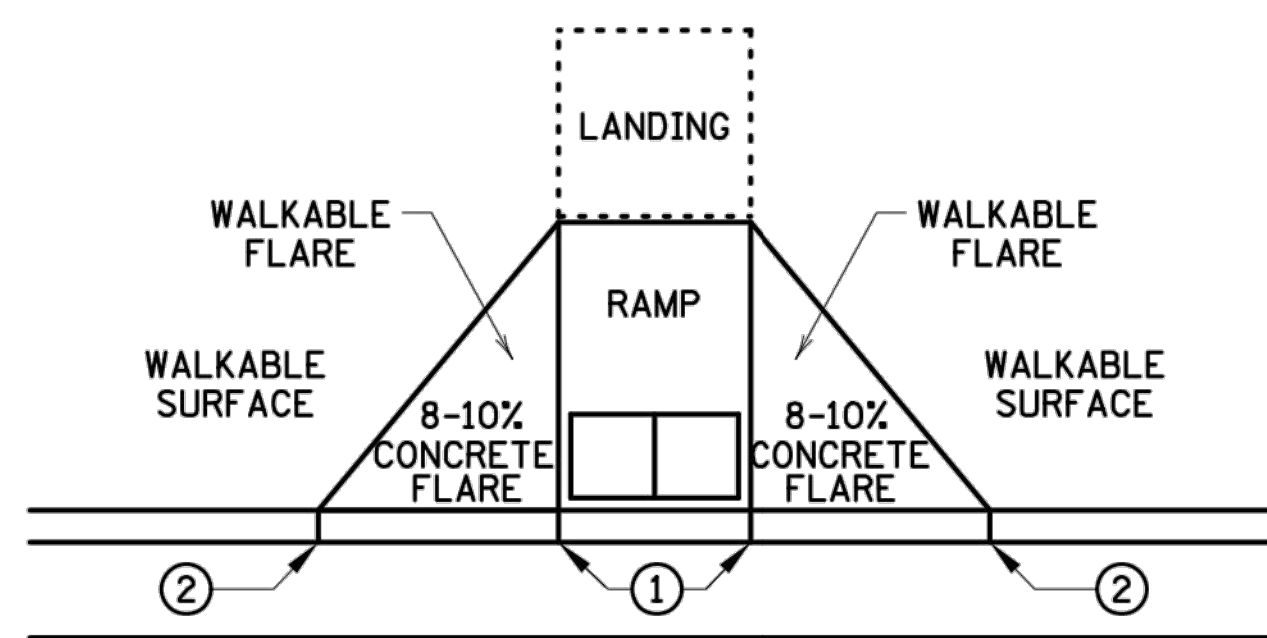

PAVED FLARES
ADJACENT TO WALKABLE SURFACE

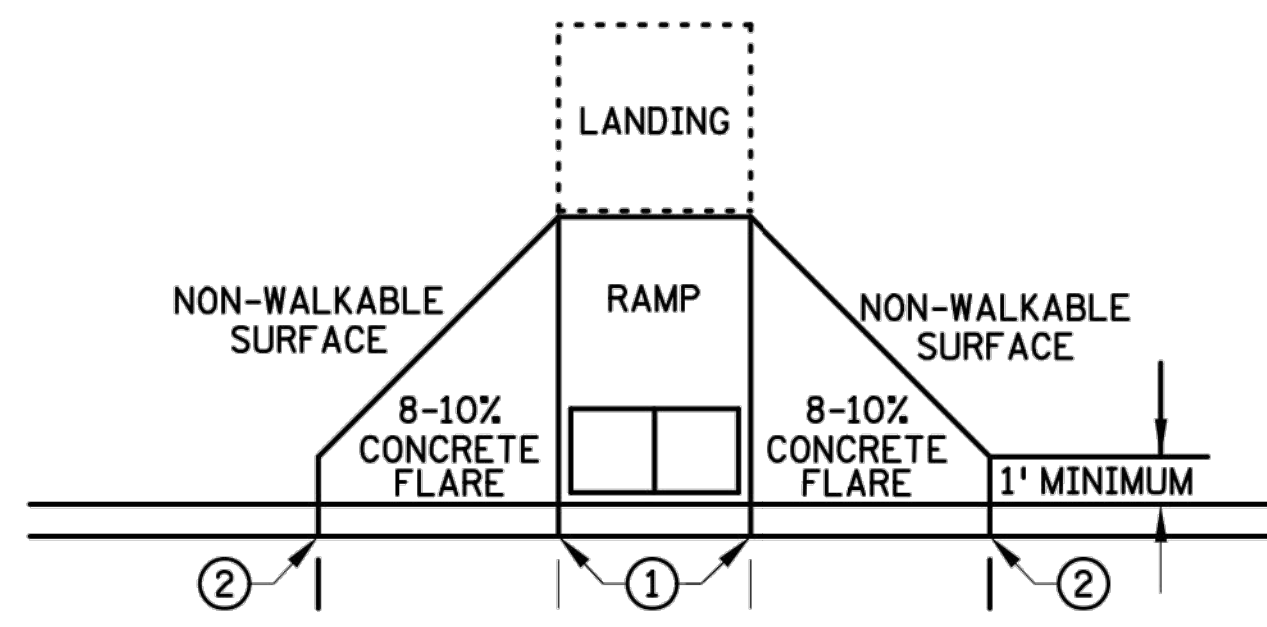

PAVED FLARES
ADJACENT TO NON-WALKABLE SURFACE

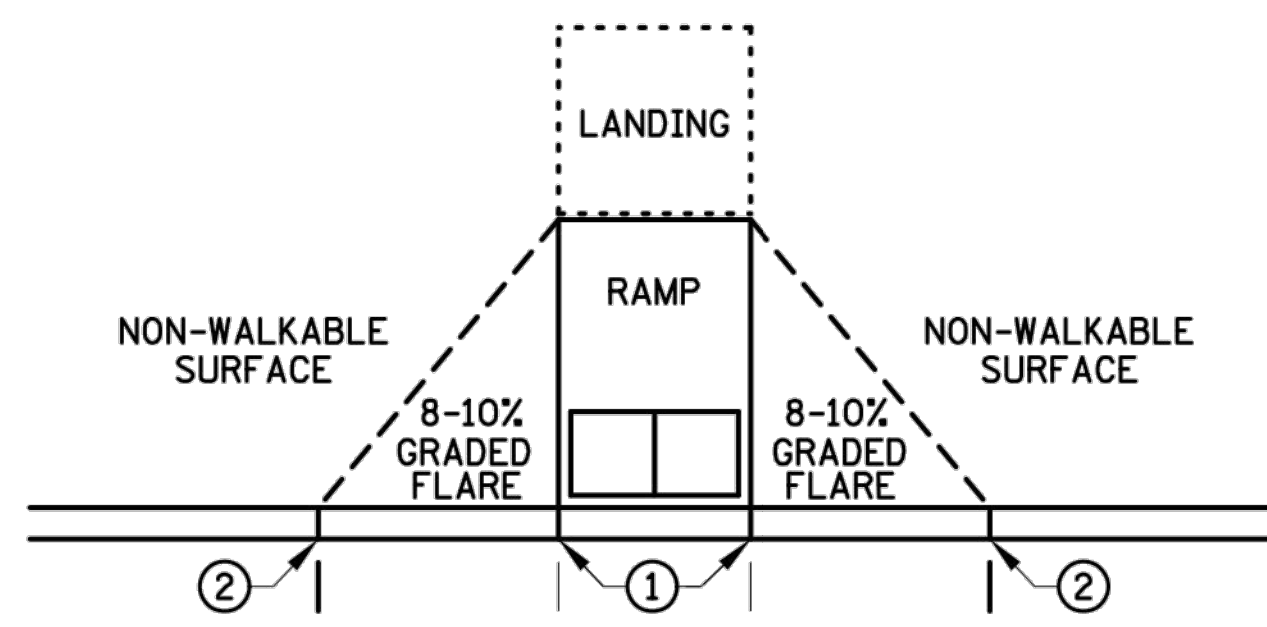

GRADED FLARES

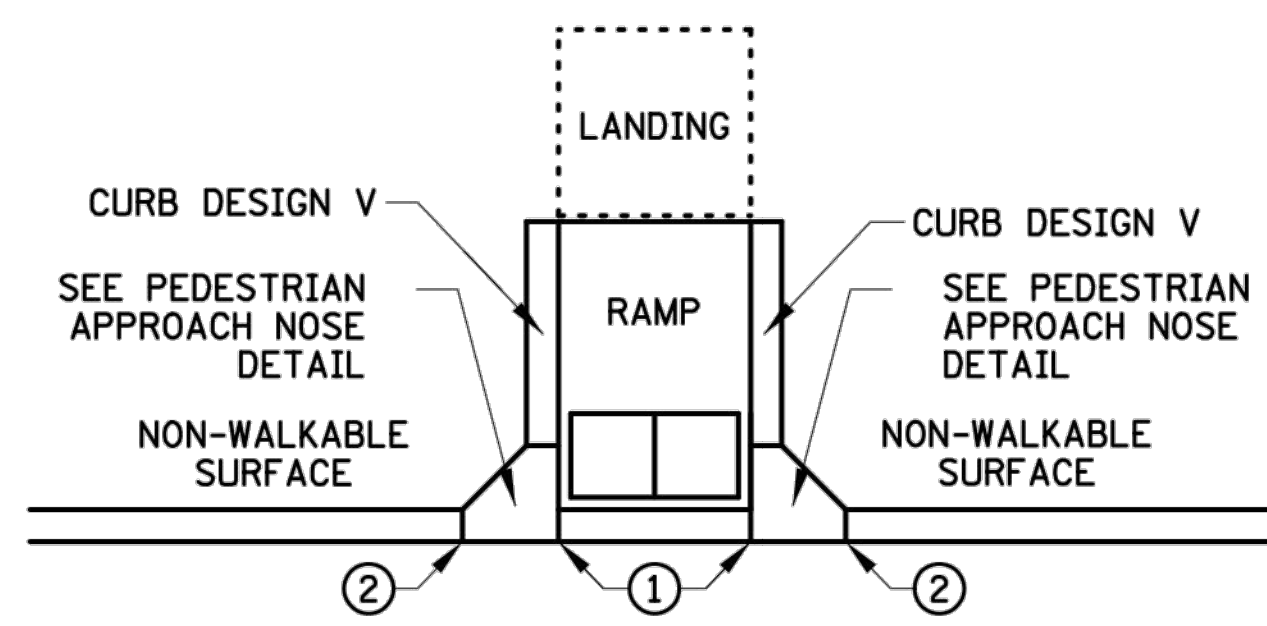

RETURNED CURB ④

TYPICAL SIDE TREATMENT OPTIONS ③ ⑩

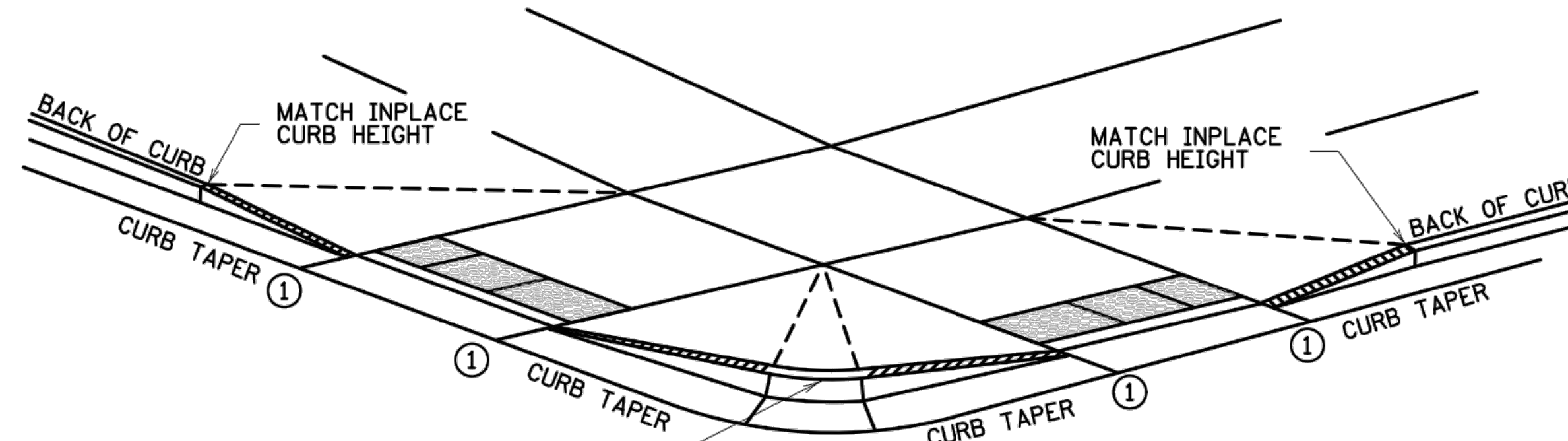

3" MINIMUM CURB HEIGHT, 4" PREFERRED
(MEASURED AT FRONT FACE OF CURB)
FOR A MIN. 6" LENGTH (MEASURED ALONG FLOW LINE)

DETECTABLE EDGE WITH
CURB AND GUTTER ⑦

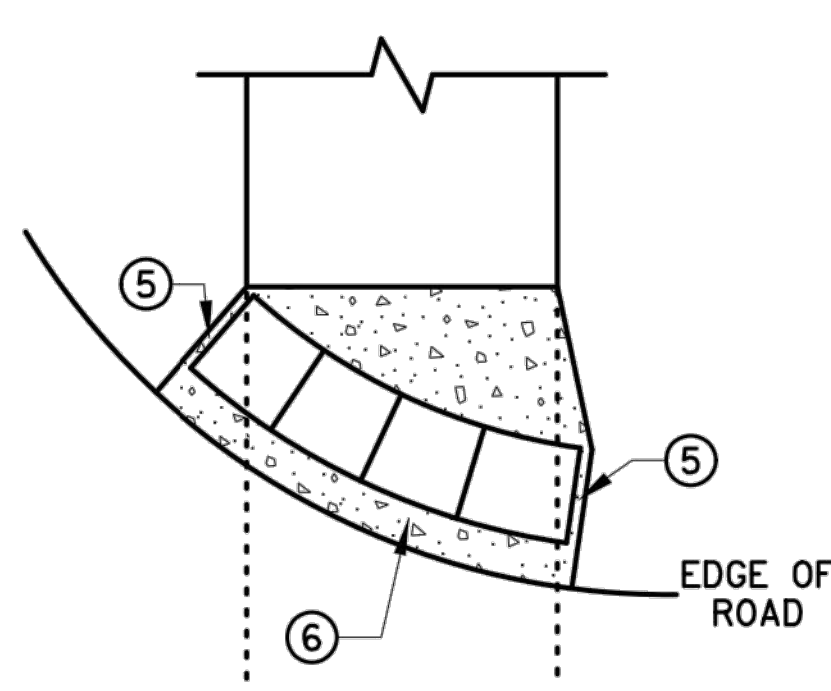

RADIAL DETECTABLE WARNING

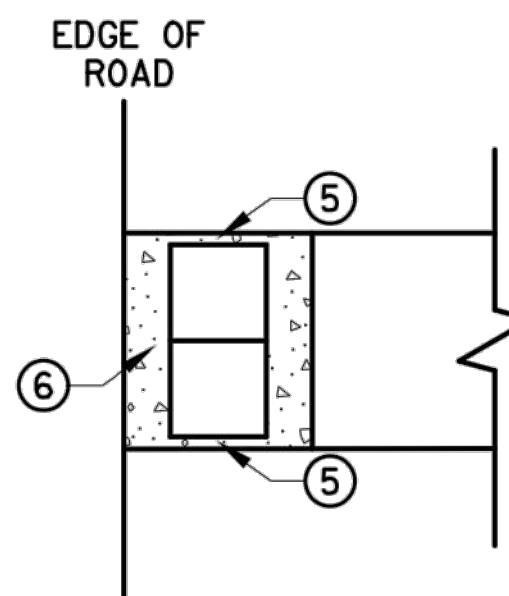

RECTANGULAR DETECTABLE WARNING

DETECTABLE EDGE WITHOUT CURB AND GUTTER

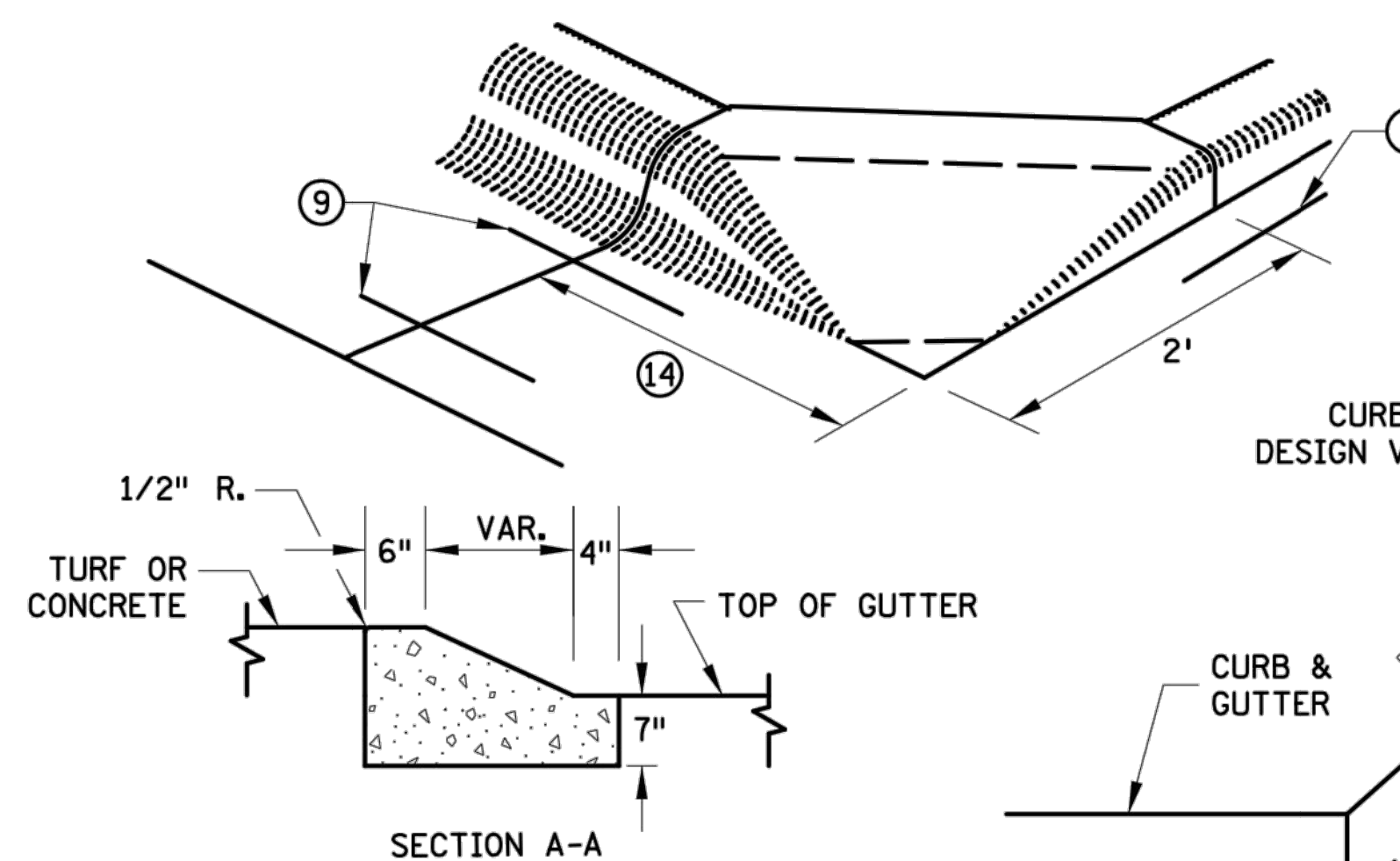

SECTION A-A

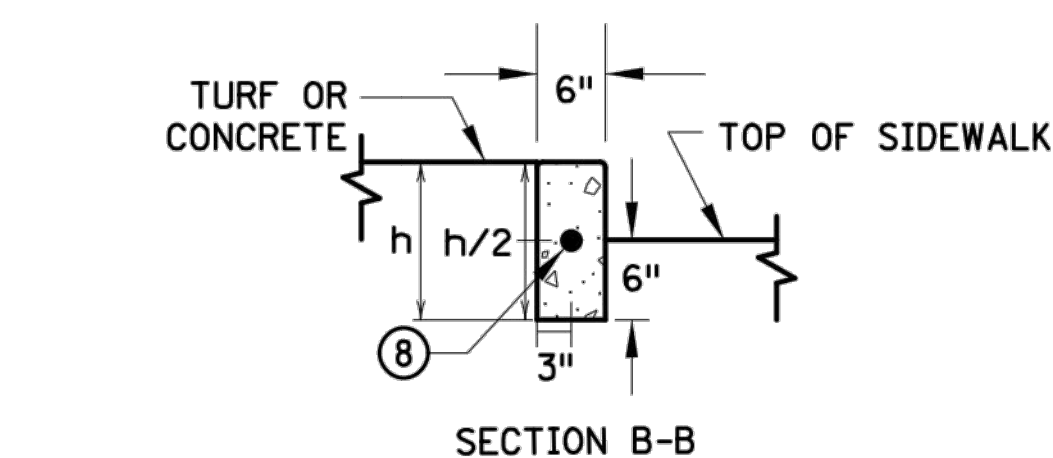

SECTION B-B

PEDESTRIAN APPROACH
NOSE DETAIL
(FOR RETURNED CURB
SIDE TREATMENT)

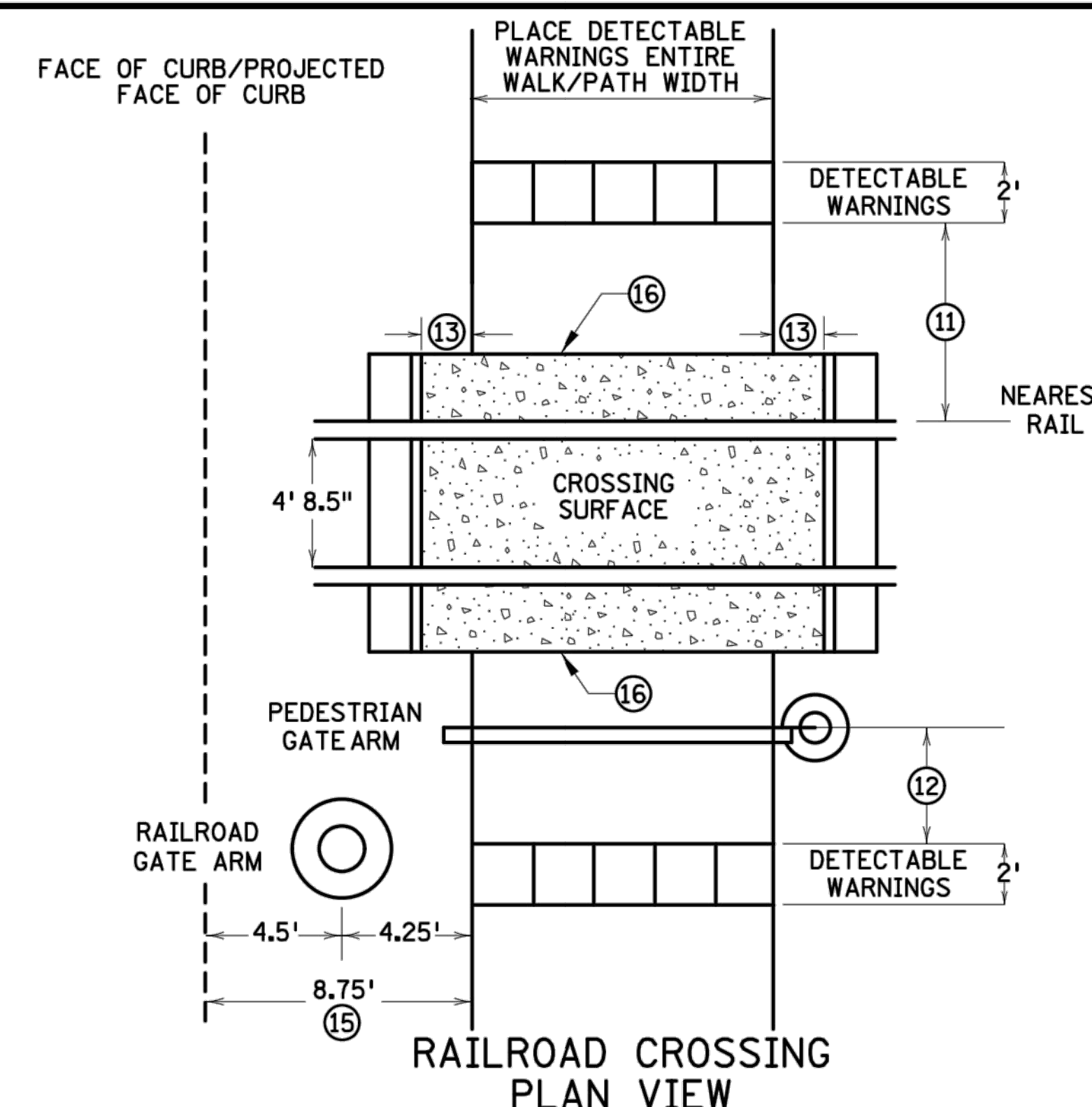

RAILROAD CROSSING
PLAN VIEW

NOTES:

- INTERMEDIATE CURB HEIGHTS TAPER SHALL RISE AT 8-10% TO A MINIMUM 3 INCH CURB HEIGHT. INCREASE CURB TAPER LENGTH AT LESS THAN 8% OR REDUCE INTERMEDIATE CURB HEIGHT TO 2+ INCHES IF NECESSARY TO MATCH ADJACENT BOULEVARD OR SIDEWALK GRADES.
- SEE STANDARD PLATE 7038 AND THIS SHEET FOR ADDITIONAL DETAILS ON DETECTABLE WARNING.
- A WALKABLE SURFACE IS DEFINED AS A PAVED SURFACE ADJACENT TO A CURB RAMP WITHOUT RAISED OBSTACLES THAT COULD MISTAKENLY BE TRAVERSED BY A USER WHO IS VISUALLY IMPAIRED.
- CONCRETE FLARE LENGTHS ADJACENT TO NON-WALKABLE SURFACES SHOULD BE LESS THAN 8' LONG MEASURED ALONG THE RAMPS FROM THE BACK OF CURB.
- ① 0" CURB HEIGHT. SEE INSET A ON SHEET 3 OF 6.
- ② FULL CURB HEIGHT.
- ③ SIDE TREATMENTS ARE APPLICABLE TO ALL RAMP TYPES AND SHOULD BE IMPLEMENTED AS NEEDED AS FIELD CONDITIONS DICTATE. THE ENGINEER SHALL DETERMINE THE RAMP SIDE TREATMENTS BASED ON MAINTENANCE OF BOTH ROADWAY AND SIDEWALK, ADJACENT PROPERTY CONSIDERATIONS, AND MITIGATING CONSTRUCTION IMPACTS.
- ④ TYPICALLY USED FOR MEDIANS AND ISLANDS.
- ⑤ WHEN NO CONCRETE FLARES ARE PROPOSED, THE CONCRETE WALK SHALL BE FORMED AND CONSTRUCTED PERPENDICULAR TO THE EDGE OF ROADWAY. MAINTAIN 3" MAX. BETWEEN EDGE OF DOMES AND EDGE OF CONCRETE.
- ⑥ IF NO CURB AND GUTTER IS PLACED IN RURAL SECTIONS, DETECTABLE WARNINGS SHALL BE PLACED 1' FROM THE EDGE OF BITUMINOUS ROADWAY AND/OR BITUMINOUS SHARED-USE PATH TO PROVIDE VISUAL CONTRAST.
- ⑦ ALL CONSTRUCTED CURBS MUST HAVE A CONTINUOUS DETECTABLE EDGE FOR THE VISUALLY IMPAIRED. THIS DETECTABLE EDGE REQUIRES DETECTABLE WARNINGS WHEREVER THERE IS ZERO-INCH HIGH CURB. CURB TAPERS ARE CONSIDERED A DETECTABLE EDGE WHEN THE TAPER STARTS WITHIN 3" OF THE EDGE OF THE DETECTABLE WARNINGS. AND UNIFORMLY RISES TO A 3-INCH MINIMUM CURB HEIGHT. ANY CURB NOT PART OF A CURB TAPER AND LESS THAN 3 INCHES IN HEIGHT IS NOT CONSIDERED A DETECTABLE EDGE AND THEREFORE IS NOT COMPLIANT WITH ACCESSIBILITY STANDARDS.
- ⑧ DRILL AND GROUT 1 - NO. 4 12" LONG REINFORCEMENT BAR (EPOXY COATED) WITH 3" MIN. COVER. REINFORCEMENT BARS ARE NOT NEEDED IF THE APPROACH NOSE IS POURED INTEGRAL WITH THE V CURB.
- ⑨ DRILL AND GROUT 2 - NO. 4 12" LONG REINFORCEMENT BARS (EPOXY COATED) WITH 3" MIN. COVER. REINFORCEMENT BARS ARE NOT NEEDED IF THE APPROACH NOSE IS POURED INTEGRAL WITH THE CURB AND GUTTER.
- ⑩ SIDE TREATMENT EXAMPLES SHOWN ARE WHEN THE INITIAL LANDING IS APPROXIMATELY LEVEL WITH THE FULL HEIGHT CURB (I.E. 6' LONG RAMP FOR 6" HIGH CURB). WHEN THE INITIAL LANDING IS MORE THAN 1" BELOW FULL HEIGHT CURB REFER TO SHEETS 1 & 2 TO MODIFY THE CURB HEIGHT TAPERS AND MAINTAIN POSITIVE BOULEVARD DRAINAGE. CONSTRUCT THESE TAPERS AT 0"-3" AT 8-10%, THEN LESS THAN 5% FROM 3" CURB TO FULL CURB HEIGHT.
- ⑪ NEAREST EDGE OF DETECTABLE WARNING SURFACES SHALL BE PLACED 12' MINIMUM TO 15' MAXIMUM FROM THE NEAREST RAIL. FOR SKEWED RAILWAYS IN NO INSTANCE SHALL THE DETECTABLE WARNING BE CLOSER THAN 12' MEASURED PERPENDICULAR TO THE NEAREST RAIL.
- ⑫ WHEN PEDESTRIAN GATES ARE PROVIDED, DETECTABLE WARNING SURFACES SHALL BE PLACED ON THE SIDE OF THE GATES OPPOSITE THE RAIL, 2' FROM THE APPROACHING SIDE OF THE GATE ARM. THIS CRITERIA GOVERNS OVER NOTE ⑪.
- ⑬ CROSSING SURFACE SHALL EXTEND 2' MINIMUM PAST THE OUTSIDE EDGE OF WALK OR SHARED-USE PATH.
- ⑭ 3' FOR MEDIANS AND SPLITTER ISLANDS. NOSE CAN BE REDUCED TO 2' ON FREE RIGHT ISLANDS.
- ⑮ SIDEWALK TO BE PLACED 8.75' MIN. FROM THE FACE OF CURB/PROJECTED FACE OF CURB. THIS ENSURES MIN. CLEARANCE BETWEEN THE SIDEWALK AND GATE ARM COUNTERWEIGHT SUPPORTS.
- ⑯ CONSTRUCT WITH EXPANSION MATERIAL PER MNDOT SPECIFICATION 3702 TYPES A-E. EXPANSION MATERIAL SHALL MATCH FULL HEIGHT OF ADJACENT CONCRETE.

REVISION:
APPROVED: 11-04-2021
Jeffrey J. Perkins
JEFFREY PERKINS
OPERATIONS DIVISION

m
MINNESOTA
DEPARTMENT
OF
TRANSPORTATION

STANDARD PLAN 5-297.250

4 OF 6

Tom Styrbicki
THOMAS STYRBICKI
STATE DESIGN ENGINEER

APPROVED: 11-04-2021
REVISED:

STATE PROJ. NO.

PEDESTRIAN CURB RAMP DETAILS

(TH) SHEET NO. 2 OF 3 SHEETS



Contract Number: BF-20246516

EXHIBIT "C"

CONTRACTOR REQUIREMENTS

1. General

1. The Contractor must cooperate with BNSF RAILWAY COMPANY, hereinafter referred to as "Railway" where work is over or under on or adjacent to Railway property and/or right-of-way, hereafter referred to as "Railway Property", during the reconstruction of the trail at DOT# 980785P in Duluth, MN.
2. The Contractor must execute and deliver to the Railway duplicate copies of the Exhibit "C-1" Agreement, in the form attached hereto, obligating the Contractor to provide and maintain in full force and effect the insurance called for under Section 3 of said Exhibit "C-1". Questions regarding procurement of the Railroad Protective Liability Insurance should be directed to Rosa Martinez at Marsh, USA, 214-303-8519.
3. The Contractor must plan, schedule and conduct all work activities so as not to interfere with the movement of any trains on Railway Property.
4. The Contractor's right to enter Railway's Property is subject to the absolute right of Railway to cause the Contractor's work on Railway's Property to cease if, in the opinion of Railway, Contractor's activities create a hazard to Railway's Property, employees, and/or operations. Railway will have the right to stop construction work on the Project if any of the following events take place: (i) Contractor (or any of its subcontractors) performs the Project work in a manner contrary to the plans and specifications approved by Railway; (ii) Contractor (or any of its subcontractors), in Railway's opinion, prosecutes the Project work in a manner which is hazardous to Railway property, facilities or the safe and expeditious movement of railroad traffic; (iii) the insurance described in the attached Exhibit C-1 is canceled during the course of the Project; or (iv) Contractor fails to pay Railway for the Temporary Construction License or the Easement. The work stoppage will continue until all necessary actions are taken by Contractor or its subcontractor to rectify the situation to the satisfaction of Railway's Division Engineer or until additional insurance has been delivered to and accepted by Railway. In the event of a breach of (i) this Agreement, (ii) the Temporary Construction License, or (iii) the Easement, Railway may immediately terminate the Temporary Construction License or the Easement. Any such work stoppage under this provision will not give rise to any liability on the part of Railway. Railway's right to stop the work is in addition to any other rights Railway may have including, but not limited to, actions or suits for damages or lost



Contract Number: BF-20246516

profits. In the event that Railway desires to stop construction work on the Project, Railway agrees to immediately notify the following individual in writing:

5. The Contractor is responsible for determining and complying with all Federal, State and Local Governmental laws and regulations, including, but not limited to environmental laws and regulations (including but not limited to the Resource Conservation and Recovery Act, as amended; the Clean Water Act, the Oil Pollution Act, the Hazardous Materials Transportation Act, CERCLA), and health and safety laws and regulations. The Contractor hereby indemnifies, defends and holds harmless Railway for, from and against all fines or penalties imposed or assessed by Federal, State and Local Governmental Agencies against the Railway which arise out of Contractor's work under this Agreement.
6. The Contractor must notify **(Agency)** at (218) 730-5105 and Railway's Manager Public Projects, telephone number 763-782-3476 at least thirty (30) calendar days before commencing any work on Railway Property. Contractor's notification to Railway must refer to Railway's file BF-20246516.
7. For any bridge demolition and/or falsework above any tracks or any excavations located with any part of the excavations located within, whichever is greater, twenty-five (25) feet of the nearest track or intersecting a slope from the plane of the top of rail on a 2 horizontal to 1 vertical slope beginning at eleven (11) feet from centerline of the nearest track, both measured perpendicular to center line of track, the Contractor must furnish the Railway five sets of working drawings showing details of construction affecting Railway Property and tracks. The working drawing must include the proposed method of installation and removal of falsework, shoring or cribbing, not included in the contract plans and two sets of structural calculations of any falsework, shoring or cribbing. For all excavation and shoring submittal plans, the current "BNSF-UPRR Guidelines for Temporary Shoring" must be used for determining the design loading conditions to be used in shoring design, and all calculations and submittals must be in accordance with the current "BNSF-UPRR Guidelines for Temporary Shoring". All submittal drawings and calculations must be stamped by a registered professional engineer licensed to practice in the state the project is located. All calculations must take into consideration railway surcharge loading and must be designed to meet American Railway Engineering and Maintenance-of-Way Association (previously known as American Railway Engineering Association) Coopers E-80 live loading standard. All drawings and



Contract Number: BF-20246516

calculations must be stamped by a registered professional engineer licensed to practice in the state the project is located. The Contractor must not begin work until notified by the Railway that plans have been approved. The Contractor will be required to use lifting devices such as, cranes and/or winches to place or to remove any falsework over Railway's tracks. In no case will the Contractor be relieved of responsibility for results obtained by the implementation of said approved plans.

8. Subject to the movement of Railway's trains, Railway will cooperate with the Contractor such that the work may be handled and performed in an efficient manner. The Contractor will have no claim whatsoever for any type of damages or for extra or additional compensation in the event his work is delayed by the Railway.

2. **Contractor Safety Orientation**

1. **No employee of the Contractor, its subcontractors, agents or invitees may enter Railway Property without first having completed Railway's Engineering Contractor Safety Orientation, found on the web site www.BNSFContractor.com. The Contractor must ensure that each of its employees, subcontractors, agents or invitees completes Railway's Engineering Contractor Safety Orientation through internet sessions before any work is performed on the Project. Additionally, the Contractor must ensure that each and every one of its employees, subcontractors, agents or invitees possesses a card certifying completion of the Railway Contractor Safety Orientation before entering Railway Property. The Contractor is responsible for the cost of the Railway Contractor Safety Orientation. The Contractor must renew the Railway Contractor Safety Orientation annually. Further clarification can be found on the web site or from the Railway's Representative.**

3. **Railway Requirements**

1. The Contractor must take protective measures as are necessary to keep railway facilities, including track ballast, free of sand, debris, and other foreign objects and materials resulting from his operations. Any damage to railway facilities resulting from Contractor's operations will be repaired or replaced by Railway and the cost of such repairs or replacement must be paid for by the Agency.
2. The Contractor must notify the Railway's Division Engineer Tyrel Antonich at 309-345-6090 and provide blasting plans to the Railway for review seven (7) calendar days prior to conducting any blasting operations adjacent to or on Railway's Property.



Contract Number: BF-20246516

3. The Contractor must abide by the following temporary clearances during construction:

- 15'-0" Horizontally from centerline of nearest track
- 21'-6" Vertically above top of rail
- 27'-0" Vertically above top of rail for electric wires carrying less than 750 volts
- 28'-0" Vertically above top of rail for electric wires carrying 750 volts to 15,000 volts
- 30'-0" Vertically above top of rail for electric wires carrying 15,000 volts to 20,000 volts
- 34'-0" Vertically above top of rail for electric wires carrying more than 20,000 volts

Upon completion of construction, the following clearances shall be maintained:

- 25' Horizontally from centerline of nearest track
- 23' 6" Vertically above top of rail

1. Any infringement within State statutory clearances due to the Contractor's operations must be submitted to the Railway and to the **(Agency)** and must not be undertaken until approved in writing by the Railway, and until the **(Agency)** has obtained any necessary authorization from the State Regulatory Authority for the infringement. No extra compensation will be allowed in the event the Contractor's work is delayed pending Railway approval, and/or the State Regulatory Authority's approval.
2. In the case of impaired vertical clearance above top of rail, Railway will have the option of installing tell-tales or other protective devices Railway deems necessary for protection of Railway operations. The cost of tell-tales or protective devices will be borne by the Agency.
3. The details of construction affecting the Railway's Property and tracks not included in the contract plans must be submitted to the Railway by **(Agency)** for approval before work is undertaken and this work must not be undertaken until approved by the Railway.
4. At other than public road crossings, the Contractor must not move any equipment or materials across Railway's tracks until permission has been obtained from the Railway. The Contractor must obtain a "Temporary Construction Crossing Agreement" from the Railway prior to moving his equipment or materials across the Railways tracks. The temporary crossing must be gated and locked at all times when not required for use by the Contractor. The temporary crossing for use of the Contractor will be constructed and, at the completion of the project, removed at the expense of the Contractor.



Contract Number: BF-20246516

5. Discharge, release or spill on the Railway Property of any hazardous substances, oil, petroleum, constituents, pollutants, contaminants, or any hazardous waste is prohibited and Contractor must immediately notify the **Railway's Resource Operations Center at 1(800) 832-5452**, of any discharge, release or spills in excess of a reportable quantity. Contractor must not allow Railway Property to become a treatment, storage or transfer facility as those terms are defined in the Resource Conservation and Recovery Act or any state analogue.
6. The Contractor upon completion of the work covered by this contract, must promptly remove from the Railway's Property all of Contractor's tools, equipment, implements and other materials, whether brought upon said property by said Contractor or any Subcontractor, employee or agent of Contractor or of any Subcontractor, and must cause Railway's Property to be left in a condition acceptable to the Railway's representative.

1. **Contractor Roadway Worker on Track Safety Program and Safety Action Plan**

1. Each Contractor that will perform work within 25 feet of the centerline of a track must develop and implement a Roadway Worker Protection/On Track Safety Program and work with Railway Project Representative to develop an on track safety strategy as described in the guidelines listed in the on track safety portion of the Safety Orientation. This Program must provide Roadway Worker protection/on track training for all employees of the Contractor, its subcontractors, agents or invitees. This training is reinforced at the job site through job safety briefings. Additionally, each Contractor must develop and implement the Safety Action Plan, as provided for on the web site www.BNSFContractor.com, which will be made available to Railway prior to commencement of any work on Railway Property. During the performance of work, the Contractor must audit its work activities. The Contractor must designate an on-site Project Supervisor who will serve as the contact person for the Railway and who will maintain a copy of the Safety Action Plan, safety audits, and Material Safety Datasheets (MSDS), at the job site.
1. Contractor shall have a background investigation performed on all of its employees, subcontractors and agents who will be performing any services for Railroad under this Agreement which are determined by Railroad in its sole discretion **a)** to be on Railroad's property, or **b)** that require access to Railroad Critical Infrastructure, Railroad Critical Information Systems, Railroad's Employees, Hazardous Materials on Railroad's property or is being transported by or otherwise in the custody of Railroad, or Freight in Transit involving Railroad.
 1. The required background screening shall at a minimum meet the rail industry background screening criteria defined by the e-RAILSAFE Program as



Contract Number: BF-20246516

outlined at www.eVerifile.com, in addition to any other applicable regulatory requirements.

2. Contractor shall obtain written consent from all its employees, subcontractors or agents screened in compliance with the e-RAILSAFE Program to participate in the Program on their behalf and to release completed background information to Railroad's designee. Contractor shall be subject to periodic audit to ensure compliance.
3. Contractor subject to the e-RAILSAFE Program hereunder shall not permit any of its employees, subcontractors or agents to perform services hereunder who are not first approved under e-RAILSAFE Program standards. Railroad shall have the right to deny entry onto its premises or access as described in this section above to any of Contractor's employees, subcontractors or agents who do not display the authorized identification badge issued by a background screening service meeting the standards set forth in the e-RAILSAFE Program, or who in Railroad's opinion, which may not be unreasonable, may pose a threat to the safety or security of Railroad's operations, assets or personnel.
4. Contractors shall be responsible for ensuring that its employees, subcontractors and agents are United States citizens or legally working in the United States under a lawful and appropriate work VISA or other work authorization.

1. **Railway Flagger Services**

1. The Contractor must give Railway's **Roadmaster Steve Muellner (telephone 715-394-1235)** a minimum of thirty (30) calendar days advance notice when flagging services will be required so that the Roadmaster can make appropriate arrangements (i.e., bulletin the flagger's position). If flagging services are scheduled in advance by the Contractor and it is subsequently determined by the parties hereto that such services are no longer necessary, the Contractor must give the Roadmaster five (5) working days advance notice so that appropriate arrangements can be made to abolish the position pursuant to union requirements.
2. Unless determined otherwise by Railway's Project Representative, Railway flagger will be required and furnished when Contractor's work activities are located over, under and/or within twenty-five (25) feet measured horizontally from centerline of the nearest track and when cranes or similar equipment positioned beyond 25-feet from the track centerline could foul the track in the event of tip over or other catastrophic occurrence, but not limited thereto for the following conditions:



Contract Number: BF-20246516

1. When, upon inspection by Railway's Representative, other conditions warrant.
 2. When any excavation is performed below the bottom of tie elevation, if, in the opinion of Railway's representative, track or other Railway facilities may be subject to movement or settlement.
 3. When work in any way interferes with the safe operation of trains at timetable speeds.
 4. When any hazard is presented to Railway track, communications, signal, electrical, or other facilities either due to persons, material, equipment or blasting in the vicinity.
 5. Special permission must be obtained from the Railway before moving heavy or cumbersome objects or equipment which might result in making the track impassable.
3. Flagging services will be performed by qualified Railway flaggers.
1. Flagging crew generally consists of one employee. However, additional personnel may be required to protect Railway Property and operations, if deemed necessary by the Railways Representative.
 2. Each time a flagger is called, the minimum period for billing will be the eight (8) hour basic day.
 3. The cost of flagger services provided by the Railway will be borne by **(Agency)**. The estimated cost for one (1) flagger is approximately between \$1,200.00-\$2,000.00 for an eight (8) hour basic day with time and one-half or double time for overtime, rest days and holidays. The estimated cost for each flagger includes vacation allowance, paid holidays, Railway and unemployment insurance, public liability and property damage insurance, health and welfare benefits, vehicle, transportation, meals, lodging, radio, equipment, supervision and other costs incidental to performing flagging services. Negotiations for Railway labor or collective bargaining agreements and rate changes authorized by appropriate Federal authorities may increase actual or estimated flagging rates. **THE FLAGGING RATE IN EFFECT AT THE TIME OF PERFORMANCE BY THE CONTRACTOR HEREUNDER WILL BE USED TO CALCULATE THE ACTUAL COSTS OF FLAGGING PURSUANT TO THIS PARAGRAPH.**



Contract Number: BF-20246516

4. The average train traffic on this route is 1 freight trains per 24-hour period at a timetable speed 10 MPH and N/A passenger trains at a timetable speed of N/A MPH.

1. Contractor General Safety Requirements

1. Work in the proximity of railway track(s) is potentially hazardous where movement of trains and equipment can occur at any time and in any direction. All work performed by contractors within 25 feet of any track must be in compliance with FRA Roadway Worker Protection Regulations.
2. Before beginning any task on Railway Property, a thorough job safety briefing must be conducted with all personnel involved with the task and repeated when the personnel or task changes. If the task is within 25 feet of any track, the job briefing must include the Railway's flagger, as applicable, and include the procedures the Contractor will use to protect its employees, subcontractors, agents or invitees from moving any equipment adjacent to or across any Railway track(s).
3. Workers must not work within 25 feet of the centerline of any track without an on track safety strategy approved by the Railway's Project Representative. When authority is provided, every contractor employee must know: (1) who the Railway flagger is, and how to contact the flagger, (2) limits of the authority, (3) the method of communication to stop and resume work, and (4) location of the designated places of safety. Persons or equipment entering flag/work limits that were not previously job briefed, must notify the flagger immediately, and be given a job briefing when working within 25 feet of the center line of track.
4. When Contractor employees are required to work on the Railway Property after normal working hours or on weekends, the Railway's representative in charge of the project must be notified. A minimum of two employees must be present at all times.
5. Any employees, agents or invitees of Contractor or its subcontractors under suspicion of being under the influence of drugs or alcohol, or in the possession of same, will be removed from the Railway's Property and subsequently released to the custody of a representative of Contractor management. Future access to the Railway's Property by that employee will be denied.
6. Any damage to Railway Property, or any hazard noticed on passing trains must be reported immediately to the Railway's representative in charge of the project. Any vehicle or machine which may come in contact with track, signal equipment, or structure (bridge) and could result in a train derailment must be reported immediately to the Railway representative in charge of the project and to the Railway's Resource Operations Center at 1(800) 832-5452. Local emergency



Contract Number: BF-20246516

numbers are to be obtained from the Railway representative in charge of the project prior to the start of any work and must be posted at the job site.

7. For safety reasons, all persons are prohibited from having pocket knives, firearms or other deadly weapons in their possession while working on Railway's Property.
8. All personnel protective equipment (PPE) used on Railway Property must meet applicable OSHA and ANSI specifications. Current Railway personnel protective equipment requirements are listed on the web site, www.BNSFContractor.com, however, a partial list of the requirements include: a) safety glasses with permanently affixed side shields (no yellow lenses); b) hard hats; c) safety shoe with: hardened toes, above-the-ankle lace-up and a defined heel; and d) high visibility retro-reflective work wear. The Railway's representative in charge of the project is to be contacted regarding local specifications for meeting requirements relating to hi-visibility work wear. Hearing protection, fall protection, gloves, and respirators must be worn as required by State and Federal regulations. **(NOTE – Should there be a discrepancy between the information contained on the web site and the information in this paragraph, the web site will govern.)**
9. **THE CONTRACTOR MUST NOT PILE OR STORE ANY MATERIALS, MACHINERY OR EQUIPMENT CLOSER THAN 25'-0" TO THE CENTER LINE OF THE NEAREST RAILWAY TRACK. MATERIALS, MACHINERY OR EQUIPMENT MUST NOT BE STORED OR LEFT WITHIN 250 FEET OF ANY HIGHWAY/RAIL AT-GRADE CROSSINGS OR TEMPORARY CONSTRUCTION CROSSING, WHERE STORAGE OF THE SAME WILL OBSTRUCT THE VIEW OF A TRAIN APPROACHING THE CROSSING. PRIOR TO BEGINNING WORK, THE CONTRACTOR MUST ESTABLISH A STORAGE AREA WITH CONCURRENCE OF THE RAILWAY'S REPRESENTATIVE.**
10. Machines or vehicles must not be left unattended with the engine running. Parked machines or equipment must be in gear with brakes set and if equipped with blade, pan or bucket, they must be lowered to the ground. All machinery and equipment left unattended on Railway's Property must be left inoperable and secured against movement. (See internet Engineering Contractor Safety Orientation program for more detailed specifications)
11. Workers must not create and leave any conditions at the work site that would interfere with water drainage. Any work performed over water must meet all Federal, State and Local regulations.
12. All power line wires must be considered dangerous and of high voltage unless informed to the contrary by proper authority. For all power lines the minimum clearance between the lines and any part of the equipment or load must be; 200 KV



Contract Number: BF-20246516

or below - 15 feet; 200 to 350 KV - 20 feet; 350 to 500 KV - 25 feet; 500 to 750 KV - 35 feet; and 750 to 1000 KV - 45 feet. If capacity of the line is not known, a minimum clearance of 45 feet must be maintained. A person must be designated to observe clearance of the equipment and give a timely warning for all operations where it is difficult for an operator to maintain the desired clearance by visual means.

1. **Excavation**

1. Before excavating, the Contractor must determine whether any underground pipe lines, electric wires, or cables, including fiber optic cable systems are present and located within the Project work area. The Contractor must determine whether excavation on Railway's Property could cause damage to buried cables resulting in delay to Railway traffic and disruption of service to users. Delays and disruptions to service may cause business interruptions involving loss of revenue and profits. Before commencing excavation, the Contractor must contact **BNSF's Field Engineering Representative Steve Muellner (715-394-1235)**. All underground and overhead wires will be considered HIGH VOLTAGE and dangerous until verified with the company having ownership of the line. **It is the Contractor's responsibility to notify any other companies that have underground utilities in the area and arrange for the location of all underground utilities before excavating.**
2. The Contractor must cease all work and notify the Railway immediately before continuing excavation in the area if obstructions are encountered which do not appear on drawings. If the obstruction is a utility and the owner of the utility can be identified, then the Contractor must also notify the owner immediately. If there is any doubt about the location of underground cables or lines of any kind, no work must be performed until the exact location has been determined. There will be no exceptions to these instructions.
3. All excavations must be conducted in compliance with applicable OSHA regulations and, regardless of depth, must be shored where there is any danger to tracks, structures or personnel.
4. Any excavations, holes or trenches on the Railway's Property must be covered, guarded and/or protected when not being worked on. When leaving work site areas at night and over weekends, the areas must be secured and left in a condition that will ensure that Railway employees and other personnel who may be working or passing through the area are protected from all hazards. All excavations must be back filled as soon as possible.

2. **Hazardous Waste, Substances and Material Reporting:**



Contract Number: BF-20246516

1. If Contractor discovers any hazardous waste, hazardous substance, petroleum or other deleterious material, including but not limited to any non-containerized commodity or material, on or adjacent to Railway's Property, in or near any surface water, swamp, wetlands or waterways, while performing any work under this Agreement, Contractor must immediately: (a) notify the Railway's Resource Operations Center at 1(800) 832-5452, of such discovery: (b) take safeguards necessary to protect its employees, subcontractors, agents and/or third parties: and (c) exercise due care with respect to the release, including the taking of any appropriate measure to minimize the impact of such release.

3. **Personal Injury Reporting**

1. The Railway is required to report certain injuries as a part of compliance with Federal Railroad Administration (FRA) reporting requirements. Any personal injury sustained by an employee of the Contractor, subcontractor or Contractor's invitees while on the Railway's Property must be reported immediately (by phone mail if unable to contact in person) to the Railway's representative in charge of the project. The Non-Employee Personal Injury Data Collection Form contained herein is to be completed and sent by Fax to the Railway at 1(817) 352-7595 and to the Railway's Project Representative no later than the close of shift on the date of the injury.



Contract Number: BF-20246516

NON-EMPLOYEE PERSONAL INJURY DATA COLLECTION

Please complete this form and provide to the BNSF supervisor, who will input this information into the EHS Star system. For questions, call (817) 352-1267 or email Safety.IncidentReporting@BNSF.com.

Accident City/State: _____ Date: _____ Time: _____

County: _____ Temperature: _____ Weather: _____
(if non-BNSF location)

Name (Last/First/MI): _____

Age: _____ Gender (if available): _____

Company: _____

eRailsafe Badge Number: _____ Expiration Date: _____

BNSF Contractor Badge Number: _____ Expiration Date: _____

Injury: _____ Body Part: _____
(e.g., laceration) (e.g., hand)

Description of accident (including how accident occurred, potential cause, etc.):

Work activity in progress at time of accident: _____

Tools, machinery, or hazardous materials involved in accident: _____

Treatment:

1. First Aid Only
2. Required Medical Treatment
3. Other Medical Treatment: _____

Dr. Name: _____ Date: _____

Dr. Street Address: _____ City: _____ State: _____ Zip: _____

Hospital Name: _____

Hospital Street Address: _____ City: _____ State: _____ Zip: _____

Diagnosis: _____

THIS REPORT IS PART OF BNSF'S ACCIDENT REPORT PURSUANT TO THE ACCIDENT REPORTS STATUTE AND, AS SUCH SHALL NOT "BE ADMITTED AS EVIDENCE OR USED FOR ANY PURPOSE IN ANY SUIT OR ACTION FOR DAMAGES GROWING OUT OF ANY MATTER MENTIONED IN SAID REPORT...." 49 U.S.C. § 20903. See 49 C.F.R. § 225.7(b).



Contract Number: BF-20246516

EXHIBIT C1
EXHIBIT "C-1"

Agreement Between
BNSF RAILWAY COMPANY
and the
CONTRACTOR

Railway File: _____

Agency Project: _____

City of Duluth, a/an (hereinafter called "Contractor"), has entered into an agreement (hereinafter called "Agreement") dated _____, 20____, for the performance of certain work in connection with the following project: reconstruction of the trail at DOT# 980785P in Duluth, MN. Performance of such work will necessarily require Contractor to enter **BNSF RAILWAY COMPANY** (hereinafter called "Railway") right of way and property (hereinafter called "Railway Property"). The Agreement provides that no work will be commenced within Railway Property until the Contractor employed in connection with said work for **The City of Duluth** (i) executes and delivers to Railway an Agreement in the form hereof, and (ii) provides insurance of the coverage and limits specified in such Agreement and Section 3 herein. If this Agreement is executed by a party who is not the Owner, General Partner, President or Vice President of Contractor, Contractor must furnish evidence to Railway certifying that the signatory is empowered to execute this Agreement on behalf of Contractor.

Accordingly, in consideration of Railway granting permission to Contractor to enter upon Railway Property and as an inducement for such entry, Contractor, effective on the date of the Agreement, has agreed and does hereby agree with Railway as follows:

1) RELEASE OF LIABILITY AND INDEMNITY

- A.** Contractor hereby waives, releases, indemnifies, defends and holds harmless Railway for all judgments, awards, claims, demands, and expenses (including attorneys' fees), for injury or death to all persons, including Railway's and Contractor's officers and employees, and for loss and damage to property



Contract Number: BF-20246516

belonging to any person, arising in any manner from Contractor's or any of Contractor's subcontractors' acts or omissions or any work performed on or about Railway's property or right-of-way. **THE LIABILITY ASSUMED BY CONTRACTOR WILL NOT BE AFFECTED BY THE FACT, IF IT IS A FACT, THAT THE DESTRUCTION, DAMAGE, DEATH, OR INJURY WAS OCCASIONED BY OR CONTRIBUTED TO BY THE NEGLIGENCE OF RAILWAY, ITS AGENTS, SERVANTS, EMPLOYEES OR OTHERWISE, EXCEPT TO THE EXTENT THAT SUCH CLAIMS ARE PROXIMATELY CAUSED BY THE INTENSIONAL MISCONDUCT OR GROSS NEGLIGENCE OF RAILWAY.**

- B. It is mutually negotiated between the parties that the indemnification obligation shall include all claims brought by Contractor's employees against Railway, its agents, servants, employees or otherwise, and Contractor expressly waives its immunity under the industrial insurance act (RCW Title 51) and assumes potential liability for all actions brought by its employees.**
- C. THE INDEMNIFICATION OBLIGATION ASSUMED BY CONTRACTOR INCLUDES ANY CLAIMS, SUITS OR JUDGMENTS BROUGHT AGAINST RAILWAY UNDER THE FEDERAL EMPLOYEE'S LIABILITY ACT, INCLUDING CLAIMS FOR STRICT LIABILITY UNDER THE SAFETY APPLIANCE ACT OR THE LOCOMOTIVE INSPECTION ACT, WHENEVER SO CLAIMED.**
- D. Contractor further agrees, at its expense, in the name and on behalf of Railway, that it will adjust and settle all claims made against Railway, and will, at Railway's discretion, appear and defend any suits or actions of law or in equity brought against Railway on any claim or cause of action arising or growing out of or in any manner connected with any liability assumed by Contractor under this Agreement for which Railway is liable or is alleged to be liable. Railway will give notice to Contractor, in writing, of the receipt or dependency of such claims and thereupon Contractor must proceed to adjust and handle to a conclusion such claims, and in the event of a suit being brought against Railway, Railway may forward summons and complaint or other process in connection therewith to Contractor, and Contractor, at Railway's discretion, must defend, adjust, or settle such suits and protect, indemnify, and save harmless Railway from and against all damages, judgments, decrees, attorney's fees, costs, and expenses growing out of or resulting from or incident to any such claims or suits.**



Contract Number: BF-20246516

- E. In addition to any other provision of this Agreement, in the event that all or any portion of this Article shall be deemed to be inapplicable for any reason, including without limitation as a result of a decision of an applicable court, legislative enactment or regulatory order, the parties agree that this Article shall be interpreted as requiring Contractor to indemnify Railway to the fullest extent permitted by applicable law. **THROUGH THIS AGREEMENT THE PARTIES EXPRESSLY INTEND FOR CONTRACTOR TO INDEMNIFY RAILWAY FOR RAILWAY'S ACTS OF NEGLIGENCE.**
- F. It is mutually understood and agreed that the assumption of liabilities and indemnification provided for in this Agreement survive any termination of this Agreement.

2) TERM

- A. This Agreement is effective from the date of the Agreement until (i) the completion of the project set forth herein, and (ii) full and complete payment to Railway of any and all sums or other amounts owing and due hereunder.

3) INSURANCE

Contractor shall, at its sole cost and expense, procure and maintain during the life of this Agreement the following insurance coverage:

- A. Commercial General Liability insurance. This insurance shall contain broad form contractual liability with a combined single limit of a minimum of \$2,000,000 each occurrence and an aggregate limit of at least \$4,000,000 but in no event less than the amount otherwise carried by the Contractor. Coverage must be purchased on a post 2004 ISO occurrence form or equivalent and include coverage for, but not limit to the following:
- ◆ Bodily Injury and Property Damage
 - ◆ Personal Injury and Advertising Injury
 - ◆ Fire legal liability
 - ◆ Products and completed operations



Contract Number: BF-20246516

This policy shall also contain the following endorsements, which shall be indicated on the certificate of insurance:

- ◆ The definition of insured contract shall be amended to remove any exclusion or other limitation for any work being done within 50 feet of railroad property.
- ◆ Waiver of subrogation in favor of and acceptable to Railway.
- ◆ Additional insured endorsement in favor of and acceptable to Railway.
- ◆ Separation of insureds.
- ◆ The policy shall be primary and non-contributing with respect to any insurance carried by Railway.

It is agreed that the workers' compensation and employers' liability related exclusions in the Commercial General Liability insurance policy(s) required herein are intended to apply to employees of the policy holder and shall not apply to **Railway** employees.

No other endorsements limiting coverage as respects obligations under this Agreement may be included on the policy with regard to the work being performed under this agreement.

B. Business Automobile Insurance. This insurance shall contain a combined single limit of at least \$1,000,000 per occurrence, and include coverage for, but not limited to the following:

- ◆ Bodily injury and property damage
- ◆ Any and all vehicles owned, used or hired

The policy shall also contain the following endorsements or language, which shall be indicated on the certificate of insurance:

- ◆ Waiver of subrogation in favor of and acceptable to Railway.
- ◆ Additional insured endorsement in favor of and acceptable to Railway.



Contract Number: BF-20246516

- ◆ Separation of insureds.
- ◆ The policy shall be primary and non-contributing with respect to any insurance carried by Railway.

C. Workers Compensation and Employers Liability insurance including coverage for, but not limited to:

- ◆ Contractor's statutory liability under the worker's compensation laws of the state(s) in which the work is to be performed. If optional under State law, the insurance must cover all employees anyway.
- ◆ Employers' Liability (Part B) with limits of at least \$500,000 each accident, \$500,000 by disease policy limit, \$500,000 by disease each employee.

This policy shall also contain the following endorsements or language, which shall be indicated on the certificate of insurance:

- ◆ Waiver of subrogation in favor of and acceptable to Railway.

A. Railroad Protective Liability insurance naming only the **Railway** as the Insured with coverage of at least \$2,000,000 per occurrence and \$6,000,000 in the aggregate. The policy Must be issued on a standard ISO form CG 00 35 12 04 and include the following:

- ◆ Endorsed to include the Pollution Exclusion Amendment
- ◆ Endorsed to include the Limited Seepage and Pollution Endorsement.
- ◆ Endorsed to remove any exclusion for punitive damages.
- ◆ No other endorsements restricting coverage may be added.
- ◆ The original policy must be provided to the **Railway** prior to performing any work or services under this Agreement
- ◆ Definition of "Physical Damage to Property" shall be endorsed to read: "means direct and accidental loss of or damage to all property owned by any named insured and all property in any named insured' care, custody, and control



Contract Number: BF-20246516

arising out of the acts or omissions of the contractor named on the Declarations.

In lieu of providing a Railroad Protective Liability Policy, Licensee may participate (if available) in Railway's Blanket Railroad Protective Liability Insurance Policy.

Other Requirements:

Where allowable by law, all policies (applying to coverage listed above) shall contain no exclusion for punitive damages.

Contractor agrees to waive its right of recovery against **Railway** for all claims and suits against **Railway**. In addition, its insurers, through the terms of the policy or policy endorsement, waive their right of subrogation against **Railway** for all claims and suits. Contractor further waives its right of recovery, and its insurers also waive their right of subrogation against **Railway** for loss of its owned or leased property or property under Contractor's care, custody or control.

Allocated Loss Expense shall be in addition to all policy limits for coverages referenced above.

Contractor is not allowed to self-insure without the prior written consent of **Railway**. If granted by **Railway**, any self-insured retention or other financial responsibility for claims shall be covered directly by Contractor in lieu of insurance. Any and all **Railway** liabilities that would otherwise, in accordance with the provisions of this Agreement, be covered by Contractor's insurance will be covered as if Contractor elected not to include a deductible, self-insured retention or other financial responsibility for claims.

Prior to commencing services, Contractor shall furnish to **Railway** an acceptable certificate(s) of insurance from an authorized representative evidencing the required coverage(s), endorsements, and amendments. The certificate should be directed to the following address:

BNSF Railway Company
c/o CertFocus
P.O. Box 140528
Kansas City, MO 64114
Toll Free: 877-576-2378
Fax number: 817-840-7487



Contract Number: BF-20246516

Email: BNSF@certfocus.com
www.certfocus.com

Contractor shall notify **Railway** in writing at least 30 days prior to any cancellation, non-renewal, substitution or material alteration.

Any insurance policy shall be written by a reputable insurance company acceptable to **Railway** or with a current Best's Guide Rating of A- and Class VII or better, and authorized to do business in the state(s) in which the service is to be provided.

If coverage is purchased on a "claims made" basis, Contractor hereby agrees to maintain coverage in force for a minimum of three years after expiration, cancellation or termination of this Agreement. Annually Contractor agrees to provide evidence of such coverage as required hereunder.

Contractor represents that this Agreement has been thoroughly reviewed by Contractor's insurance agent(s)/broker(s), who have been instructed by Contractor to procure the insurance coverage required by this Agreement.

Not more frequently than once every five years, **Railway** may reasonably modify the required insurance coverage to reflect then-current risk management practices in the railroad industry and underwriting practices in the insurance industry.

If any portion of the operation is to be subcontracted by Contractor, Contractor shall require that the subcontractor shall provide and maintain insurance coverage(s) as set forth herein, naming **Railway** as an additional insured, and shall require that the subcontractor shall release, defend and indemnify **Railway** to the same extent and under the same terms and conditions as Contractor is required to release, defend and indemnify **Railway** herein.

Failure to provide evidence as required by this section shall entitle, but not require, **Railway** to terminate this Agreement immediately. Acceptance of a certificate that does not comply with this section shall not operate as a waiver of Contractor's obligations hereunder.

The fact that insurance (including, without limitation, self-insurance) is obtained by Contractor shall not be deemed to release or diminish the liability of Contractor including, without limitation, liability under the indemnity provisions of this Agreement. Damages recoverable by **Railway** shall not be limited by the amount of the required insurance coverage.

In the event of a claim or lawsuit involving **Railway** arising out of this agreement, Contractor will make available any required policy covering such claim or lawsuit.



Contract Number: BF-20246516

These insurance provisions are intended to be a separate and distinct obligation on the part of the Contractor. Therefore, these provisions shall be enforceable and Contractor shall be bound thereby regardless of whether or not indemnity provisions are determined to be enforceable in the jurisdiction in which the work covered hereunder is performed.

For purposes of this section, **Railway** shall mean "Burlington Northern Santa Fe LLC", "BNSF Railway Company" and the subsidiaries, successors, assigns and affiliates of each.

4) SALES AND OTHER TAXES

- A.** In the event applicable sales taxes of a state or political subdivision of a state of the United States are levied or assessed in connection with and directly related to any amounts invoiced by Contractor to Railway ("Sales Taxes"), Railway shall be responsible for paying only the Sales Taxes that Contractor separately states on the invoice or other billing documents provided to Railway; *provided, however*, that (i) nothing herein shall preclude Railway from claiming whatever Sales Tax exemptions are applicable to amounts Contractor bills Railway, (ii) Contractor shall be responsible for all sales, use, excise, consumption, services and other taxes which may accrue on all services, materials, equipment, supplies or fixtures that Contractor and its subcontractors use or consume in the performance of this Agreement, (iii) Contractor shall be responsible for Sales Taxes (together with any penalties, fines or interest thereon) that Contractor fails to separately state on the invoice or other billing documents provided to Railway or fails to collect at the time of payment by Railway of invoiced amounts (except where Railway claims a Sales Tax exemption), and (iv) Contractor shall be responsible for Sales Taxes (together with any penalties, fines or interest thereon) if Contractor fails to issue separate invoices for each state in which Contractor delivers goods, provides services or, if applicable, transfers intangible rights to Railway.
- B.** Upon request, Contractor shall provide Railway satisfactory evidence that all taxes (together with any penalties, fines or interest thereon) that Contractor is responsible to pay under this Agreement have been paid. If a written claim is made against Contractor for Sales Taxes with respect to which Railway may be liable for under this Agreement, Contractor shall promptly notify Railway of such claim and provide Railway copies of all correspondence received from the taxing authority. Railway shall have the right to contest, protest, or claim a refund, in Railway's own name, any Sales Taxes paid by Railway to Contractor or for which Railway might otherwise be responsible for under this Agreement; *provided, however*, that if Railway is not permitted by law to contest any such Sales Tax in



Contract Number: BF-20246516

its own name, Contractor shall, if requested by Railway at Railway's sole cost and expense, contest in Contractor's own name the validity, applicability or amount of such Sales Tax and allow Railway to control and conduct such contest.

- C. Railway retains the right to withhold from payments made under this Agreement amounts required to be withheld under tax laws of any jurisdiction. If Contractor is claiming a withholding exemption or a reduction in the withholding rate of any jurisdiction on any payments under this Agreement, before any payments are made (and in each succeeding period or year as required by law), Contractor agrees to furnish to Railway a properly completed exemption form prescribed by such jurisdiction. Contractor shall be responsible for any taxes, interest or penalties assessed against Railway with respect to withholding taxes that Railway does not withhold from payments to Contractor.

5) EXHIBIT "C" CONTRACTOR REQUIREMENTS

- A. The Contractor must observe and comply with all provisions, obligations, requirements and limitations contained in the Agreement, and the Contractor Requirements set forth on Exhibit "C" attached to the Agreement and this Agreement, including, but not be limited to, payment of all costs incurred for any damages to Railway roadbed, tracks, and/or appurtenances thereto, resulting from use, occupancy, or presence of its employees, representatives, or agents or subcontractors on or about the construction site. Contractor shall execute a Temporary Construction Crossing Agreement or Private Crossing Agreement (<http://www.bnsf.com/communities/faqs/permits-real-estate/>), for any temporary crossing requested to aid in the construction of this Project, if approved by BNSF.

6) TRAIN DELAY

- A. Contractor is responsible for and hereby indemnifies and holds harmless Railway (including its affiliated railway companies, and its tenants) for, from and against all damages arising from any unscheduled delay to a freight or passenger train which affects Railway's ability to fully utilize its equipment and to meet customer service and contract obligations. Contractor will be billed, as further provided below, for the economic losses arising from loss of use of equipment, contractual loss of incentive pay and bonuses and contractual penalties resulting from train delays, whether caused by Contractor, or subcontractors, or by the Railway performing work under this Agreement. Railway agrees that it will not perform any act to unnecessarily cause train delay.



Contract Number: BF-20246516

- B.** For loss of use of equipment, Contractor will be billed the current freight train hour rate per train as determined from Railway's records. Any disruption to train traffic may cause delays to multiple trains at the same time for the same period.
- C.** Additionally, the parties acknowledge that passenger, U.S. mail trains and certain other grain, intermodal, coal and freight trains operate under incentive/penalty contracts between Railway and its customer(s). Under these arrangements, if Railway does not meet its contract service commitments, Railway may suffer loss of performance or incentive pay and/or be subject to penalty payments. Contractor is responsible for any train performance and incentive penalties or other contractual economic losses actually incurred by Railway which are attributable to a train delay caused by Contractor or its subcontractors.
- D.** The contractual relationship between Railway and its customers is proprietary and confidential. In the event of a train delay covered by this Agreement, Railway will share information relevant to any train delay to the extent consistent with Railway confidentiality obligations. The rate then in effect at the time of performance by the Contractor hereunder will be used to calculate the actual costs of train delay pursuant to this agreement.
- E.** Contractor and its subcontractors must give Railway's representative Steve Muellner (4) weeks advance notice of the times and dates for proposed work windows. Railway and Contractor will establish mutually agreeable work windows for the project. Railway has the right at any time to revise or change the work windows due to train operations or service obligations. Railway will not be responsible for any additional costs or expenses resulting from a change in work windows. Additional costs or expenses resulting from a change in work windows shall be accounted for in Contractor's expenses for the project.
- F.** Contractor and subcontractors must plan, schedule, coordinate and conduct all Contractor's work so as to not cause any delays to any trains.

SIGNATURE PAGE FOLLOWS



Contract Number: BF-20246516

IN WITNESS WHEREOF, each of the parties hereto has caused this Agreement to be executed by its duly authorized officer the day and year first above written.

Contractor Legal Name
Signature: _____
Printed Name: _____
Title: _____
Date: _____

BNSF RAILWAY COMPANY
Signature: _____
Printed Name: _____
Title: Manager Public Projects
Date: _____

Accepted and effective this _____ day of 20_____.

Contact Person: _____
Address: _____
City: _____
State: _____
Fax: _____
Phone: _____
E-mail: _____

Zip: _____



Contract Number: BF-20246516

EXHIBIT D

AUTHORITY FOR EXPENDITURE

LOCATION : RIVERSIDE JCT	LINE SEGMENT : 235	AFE NUMBER :
PLANITEM NUMBER : 923020000	MILEPOST : 7.68	RFA NUMBER : 5918523
PROPERTY OF : BNSF RAILWAY COMPANY	DIVISION : TC	CPAR NUMBER : CB960023
OPERATED BY : BNSF RAILWAY COMPANY	SUBDIVISION : WEST DUL - NEW DUL	BUDGET YEAR : 2023
JOINT FACILITY : CITY OF DULUTH	TRACK TYPE : 7	BUDGET CLASS : 6
% BILLABLE (+/-) : 100.0	TAX STATE : MN	REPORTING OFFICE : 121
	SPONSOR : VP ENGINEERING	CENTER/ROLLUP : 13540

PURPOSE, JUSTIFICATION AND DESCRIPTION

PIP, TCE DIV, WEST DUL - NEW DUL, LS 238, MP 7.68, CITY OF DULUTH HAS AN EXISTING TRAIL CROSSING (BUT DOES NOT HAVE AN ACTIVE DOT#). CITY HAS A TRAIL EASEMENT GRANTED BY BNSF IN 1982 - HOWEVER CURRENT TRAIL ALIGNMENT IS NOT LOCATED WITHIN THEIR EASEMENT

PRIMARY FUNDING SOURCE IS FHWA

** BUY AMERICA(N) APPLIES **

PLAN ITEM	LINE SEG	BEG MP	END MP	TRK NBR	BEGIN STATION	END STATION	PROJECT TYPE	BUD YEAR
923020000	235	7.68	7.68	7	RIVERSIDE JCT	RIVERSIDE JCT	PUBLIC IMPROVEMENT PROJECT	2023

	CASH CAPITAL	NONCASH CAPITAL	OPERATING EXP	REMOVAL COSTS	BILLABLE	TOTALS
LABOR COSTS	0	0	0	0	50,676	50,676
MATERIAL COSTS	0	0	0	0	39,500	39,500
OTHER COSTS	0	0	0	0	8,507	8,507
TOTALS	0	0	0	0	98,683	98,683

SYSTEM MAINTENANCE AND PLANNING

ESTIMATE REF. NUMBER: 5918523

COSTING DATE: 03/22/2023

PRINTED ON: 03/22/2023

ESTIMATED BY: SMITH2

PRINTED BY: SMITH2



Contract Number: BF-20246516

EXHIBIT E

LICENSE FOR BICYCLE PATH/PEDESTRIAN WALKWAY

THIS LICENSE FOR BICYCLE PATH/PEDESTRIAN WALKWAY ("**License**"), is made to be effective _____, 20__ (the "**Effective Date**") by and between **BNSF RAILWAY COMPANY**, a Delaware corporation ("**Licensor**"), and **CITY OF DULUTH** ("**Licensee**").

In consideration of the mutual covenants contained herein, the parties agree to the following:

GENERAL

1. **Grant of License.** Licensor hereby grants Licensee a non-exclusive license, subject to all rights, interests, and estates of third parties, including, without limitation, any leases, use rights, easements, liens or other encumbrances, and upon the terms and conditions set forth below, to construct and maintain, in strict accordance with the drawings and specifications approved by Licensor as part of Licensee's application process (the "**Drawings and Specifications**"), a pedestrian walkway (the "**Trail**") across or along Licensor's rail corridor at or near Duluth, County of St. Louis, State of Minnesota, Line Segment 0235/0028, Mile Post 7.68, 7.71 as shown on the attached Drawing No. 88183, dated July 19, 2023, attached hereto as **Exhibit "A"** and incorporated herein by reference (the "**Premises**").
2. **Term.** This License shall commence on the Effective Date and shall continue for a period of twenty-five (25) years, subject to prior termination as hereinafter described.
3. **Existing Improvements.** Licensee shall not disturb any improvements of Licensor or Licensor's existing lessees, licensees, easement beneficiaries or lien holders, if any, or interfere with the use, repair, maintenance or replacement of such improvements.
4. **Use of the Premises.** Licensee shall use the Premises solely for construction, maintenance and use of the Trail in accordance with the Drawings and Specifications. Licensee shall not use the Premises for any other purpose.
5. **Alterations.** Except as set forth in this License, Licensee may not make any alterations to the Premises or permanently affix anything to the Premises or any buildings or other structures adjacent to the Premises without Licensor's prior written consent

COMPENSATION

6. **License Fee.** Licensee shall pay Licensor, prior to the Effective Date, the sum of four thousand two hundred fifty-three and No/100 Dollars (\$4,253.00) as compensation for the use of the Premises.
7. **Costs and Expenses.**
 - 7.1 For the purpose of this License, "cost" or "costs" and "expense" or "expenses" includes, but is not limited to, actual labor and material costs including all assignable additives, and material and supply costs at current value where used.
 - 7.2 Licensee agrees to reimburse Licensor (pursuant to the terms of **Section 8** below) for all costs and expenses incurred by Licensor in connection with Licensee's use of the Premises, or the presence, construction and maintenance of the Trail including but not limited to the furnishing of Licensor's flaggers and any vehicle rental costs incurred. Licensee shall bear the cost of flagger services and other safety measures provided by Licensor, when deemed necessary by Licensor's representative. Flagging costs shall include, but not be limited to, the following: pay for at least an eight (8) hour basic day with time and one-half or double time for overtime, rest days and holidays (as applicable); vacation allowance; paid holidays (as applicable); railway and unemployment insurance; public liability and property damage insurance; health and welfare benefits; transportation; meals; lodging and supervision.

Negotiations for railway labor or collective bargaining agreements and rate changes authorized by appropriate Federal authorities may increase flagging rates. Flagging rates in effect at the time of performance by the flaggers will be used to calculate the flagging costs pursuant to this **Section 7**.

8. **Payment Terms.** All invoices are due thirty (30) days after the date of invoice. If Licensee fails to pay any monies due to Licensor within thirty (30) days after the invoice date, then Licensee shall pay interest on such unpaid sum from the due date until paid at an annual rate equal to the lesser of (i) the prime rate last published in *The Wall Street Journal* in the preceding December plus two and one-half percent (2.5%), or (ii) the maximum rate permitted by law.

LICENSOR'S RESERVED RIGHTS

9. **Reserved Rights of Use.** Licensor excepts and reserves the right, to be exercised by Licensor and any other parties who may obtain written permission or authority from Licensor:
- 9.1 to maintain, use, operate, repair, replace, modify and relocate any utility, power or communication pipe/lines/cables and appurtenances (other than the Trail) and other facilities or structures of like character upon, over, under or across the Premises existing as of the Effective Date;
- 9.2 to construct, maintain, renew, use, operate, change, modify and relocate any tracks or additional facilities, structures and related appurtenances upon, over, under or across the Premises; or
- 9.3 to use the Premises in any manner as Licensor in its sole discretion deems appropriate, provided Licensor uses all commercially reasonable efforts to avoid material interference with the use of the Premises by Licensee for the purpose specified in **Section 4** above.
10. **Right to Require Relocation.** If at any time during the term of this License, Licensor desires the use of its rail corridor in such a manner as would, in Licensor's reasonable opinion, be interfered with by the Trail, Licensee shall, at its sole expense, within thirty (30) days after receiving written notice from Licensor to such effect, make such changes in the Trail as in the sole discretion of Licensor may be necessary to avoid interference with the proposed use of Licensor's rail corridor, including, without limitation, the relocation of Trail the or the construction of a new trail to replace the Trail. Notwithstanding the foregoing, Licensee agrees to make all emergency changes and minor adjustments, as determined by Licensor in its sole discretion, to the Trail promptly upon Licensor's request.

LICENSEE'S OPERATIONS

11. **Construction and Maintenance of the Trail.**
- 11.1 Licensee shall notify Licensor's Roadmaster, Steven.Muellner@bnsf.com at 2304 N 28th St Superior, WI 54880, telephone (715) 394-1235, at least ten (10) business days prior to entry onto the Premises for construction of the Trail and prior to entering the Premises for any subsequent maintenance thereon. In the event of emergency, Licensee shall notify Licensor of Licensee's entry onto the Premises at the telephone number above as soon as practicable and shall promptly thereafter follow up with written notice of such entry.
- 11.2 Licensee's on-site supervisors shall retain/maintain a fully executed copy of this License at all times while on the Premises.
- 11.3 While on the Premises, Licensee shall use only public roadways to cross from one side of Licensor's tracks to the other.

- 11.4 Any contractors or subcontractors performing work on the Trail or entering the Premises on behalf of Licensee shall be deemed servants and agents of Licensee for purposes of this License.
- 11.5 Under no conditions shall Licensee be permitted to conduct any tests, investigations or any other activity using mechanized equipment and/or machinery, or place or store any mechanized equipment, tools or other materials, within twenty-five (25) feet of the centerline of any railroad track on the Premises unless Licensee has obtained prior written approval from Licensor. Licensee shall, at its sole cost and expense, perform all activities on and about the Premises in such a manner as not at any time to endanger or interfere with (i) the existence or use of present or future tracks, roadbeds, or property of Licensor, (ii) the safe operation and activities of Licensor or existing third parties, or (iii) the rights or interests of third parties. If ordered to cease using the Premises at any time by Licensor's personnel due to any hazardous condition, Licensee shall immediately do so. Notwithstanding the foregoing right of Licensor, the parties agree that Licensor has no duty or obligation to monitor Licensee's use of the Premises to determine the safe nature thereof, it being solely Licensee's responsibility to ensure that Licensee's use of the Premises is safe. Neither the exercise nor the failure by Licensor to exercise any rights granted in this Section will alter the liability allocation provided by this License.
- 11.6 Licensee shall, at its sole cost and expense, construct and maintain the Trail in such a manner and of such material that the Trail will not at any time endanger or interfere with (i) the existence or use of present or future tracks, roadbeds, or property of Licensor, (ii) the safe operation and activities of Licensor or existing third parties, or (iii) the rights or interests of third parties. The construction of the Trail shall be completed within one (1) year of the Effective Date, and any subsequent maintenance shall be completed within one (1) year of initiation. Within fifteen (15) days after completion of the construction of the Trail or the performance of any subsequent maintenance thereon, Licensee shall, at Licensee's own cost and expense, restore the Premises to substantially their state as of the Effective Date, unless otherwise approved in advance by Licensor in writing. On or before expiration or termination of this License for any reason, Licensee shall, at its sole cost and expense, surrender the Premises to Licensor pursuant to the terms and conditions set forth in **Section 24** hereof.
- 11.7 Licensor may direct one or more of its field engineers to observe or inspect the construction and/or maintenance of the Trail at any time for compliance with the Drawings and Specifications and Legal Requirements (defined below). If ordered at any time to halt construction or maintenance of the Trail by Licensor's personnel due to non-compliance with the Drawings and Specifications or any other hazardous condition, Licensee shall immediately do so. Notwithstanding the foregoing right of Licensor, the parties agree that Licensor has no duty or obligation to observe or inspect, or to halt work on, the Trail, it being solely Licensee's responsibility to ensure that the Trail is constructed and maintained in strict accordance with the Drawings and Specifications and in a safe and workmanlike manner in compliance with all terms hereof. Neither the exercise of, nor the failure by Licensor to exercise, any right granted by this Section will alter in any way the liability allocation provided by this License. If at any time Licensee shall, in the sole judgment of Licensor, fail to properly perform its obligations under this **Section 11**, Licensor may, at its option and at Licensee's sole expense, arrange for the performance of such work as it deems necessary for the safety of its operations and activities. Licensee shall promptly reimburse Licensor for all costs and expenses of such work, pursuant to the terms of **Section 8**. Licensor's failure to perform any obligations of Licensee shall not alter the liability allocation hereunder.
12. Boring and Excavation.
- 12.1 Prior to Licensee conducting any boring, excavation, or similar work on or about any portion of the Premises, Licensee shall explore the proposed location for such work with hand tools

to a depth of at least three (3) feet below the surface of the ground to determine whether pipelines or other structures exist below the surface, provided, however, that in lieu of the foregoing, Licensee shall have the right to use suitable detection equipment or other generally accepted industry practice (e.g., consulting with the Underground Services Association) to determine the existence or location of pipelines and other subsurface structures prior to drilling or excavating with mechanized equipment. Licensee may request information from Licensor concerning the existence and approximate location of Licensor's underground lines, utilities, and pipelines at or near the vicinity of the proposed Trail by contacting Licensor's Telecommunications Helpdesk at least thirty (30) business days prior to installation of the Trail. Upon receiving Licensee's timely request, Licensor will provide Licensee with the information Licensor has in its possession regarding any existing underground lines, utilities, and pipelines at or near the vicinity of the proposed Trail and, if applicable, identify the location of such lines on the Premises pursuant to Licensor's standard procedures. Licensor does not warrant the accuracy or completeness of information relating to subsurface conditions of the Premises and Licensee's operations will be subject at all times to the liability provisions herein.

- 12.2 For all bores greater than twenty-six (26) inch diameter and at a depth less than ten (10) feet below bottom of rail, a soil investigation must be performed by Licensee and reviewed by Licensor prior to construction. This study is to determine if granular material is present, and to prevent subsidence during the installation process. If the investigation determines in Licensor's reasonable opinion that granular material is present, Licensor may select a new location for Licensee's use, or may require Licensee to furnish for Licensor's review and approval, in Licensor's sole discretion a remedial plan to deal with the granular material. Once Licensor has approved any such remedial plan in writing, Licensee shall, at Licensee's sole cost and expense, carry out the approved plan in accordance with all terms thereof and hereof.
- 12.3 Any open hole, boring or well constructed on the Premises by Licensee shall be safely covered and secured at all times when Licensee is not working in the actual vicinity thereof. Following completion of that portion of the work, all holes or borings constructed on the Premises by Licensee shall be:
- 12.3.1 filled in to surrounding ground level with compacted bentonite grout; or
- 12.3.2 otherwise secured or retired in accordance with any applicable Legal Requirement. No excavated materials may remain on Licensor's property for more than ten (10) days, but must be properly disposed of by Licensee in accordance with applicable Legal Requirements.

LIABILITY AND INSURANCE

13. Liability and Indemnification.

- 13.1 For purposes of this License: (a) "**Indemnitees**" means Licensor and Licensor's affiliated companies, partners, successors, assigns, legal representatives, officers, directors, shareholders, employees, and agents; (b) "**Liabilities**" means all claims, liabilities, fines, penalties, costs, damages, losses, liens, causes of action, suits, demands, judgments, and expenses (including, without limitation, court costs, reasonable attorneys' fees, costs of investigation, removal and remediation, and governmental oversight costs) environmental or otherwise; and (c) "**Licensee Parties**" means Licensee and Licensee's officers, agents, invitees (including, but not limited to, member of the general public), licensees, employees, or contractors, or any party directly or indirectly employed by any of them, or any party they control or exercise control over.

- 13.2 **TO THE FULLEST EXTENT PERMITTED BY LAW, LICENSEE SHALL, AND SHALL CAUSE ITS CONTRACTOR TO, RELEASE, INDEMNIFY, DEFEND AND HOLD HARMLESS INDEMNITEES FOR, FROM, AND AGAINST ANY AND ALL LIABILITIES OF ANY NATURE, KIND, OR DESCRIPTION DIRECTLY OR INDIRECTLY ARISING OUT OF, RESULTING FROM, OR RELATED TO (IN WHOLE OR IN PART):**
- 13.2.1 **THIS LICENSE, INCLUDING, WITHOUT LIMITATION, ITS ENVIRONMENTAL PROVISIONS,**
- 13.2.2 **ANY RIGHTS OR INTERESTS GRANTED PURSUANT TO THIS LICENSE,**
- 13.2.3 **LICENSEE'S OCCUPATION AND USE OF THE PREMISES,**
- 13.2.4 **THE ENVIRONMENTAL CONDITION AND STATUS OF THE PREMISES CAUSED BY OR CONTRIBUTED TO BY LICENSEE, OR**
- 13.2.5 **ANY ACT OR OMISSION OF ANY LICENSEE PARTY.**
- 13.3 **TO THE FULLEST EXTENT PERMITTED BY LAW, LICENSEE NOW AND FOREVER WAIVES ANY AND ALL CLAIMS THAT BY VIRTUE OF ENTERING INTO THIS LICENSE, LICENSOR IS A GENERATOR, OWNER, OPERATOR, ARRANGER, OR TRANSPORTER FOR THE PURPOSES OF THE COMPREHENSIVE ENVIRONMENTAL RESPONSE, COMPENSATION, AND LIABILITY ACT, AS AMENDED ("CERCLA") OR OTHER ENVIRONMENTAL LAWS (DEFINED BELOW). LICENSEE WILL INDEMNIFY, DEFEND, AND HOLD THE INDEMNITEES HARMLESS FROM ANY AND ALL SUCH CLAIMS. NOTHING IN THIS LICENSE IS MEANT BY EITHER PARTY TO CONSTITUTE A WAIVER OF ANY INDEMNITEE'S COMMON CARRIER DEFENSES AND THIS LICENSE SHOULD NOT BE SO CONSTRUED. IF ANY AGENCY OR COURT CONSTRUES THIS LICENSE TO BE A WAIVER OF ANY INDEMNITEE'S COMMON CARRIER DEFENSES, LICENSEE AGREES TO INDEMNIFY, HOLD HARMLESS, AND DEFEND INDEMNITEES FOR ANY LIABILITIES RELATED TO THAT CONSTRUCTION OF THIS LICENSE. IN NO EVENT AS BETWEEN LICENSOR AND LICENSEE AS TO USE OF THE PREMISES AS CONTEMPLATED BY THIS LICENSE SHALL LICENSOR BE RESPONSIBLE TO LICENSEE FOR THE ENVIRONMENTAL CONDITION OF THE PREMISES.**
- 13.4 **IF ANY EMPLOYEE OF ANY LICENSEE PARTY ASSERTS THAT HE OR SHE IS AN EMPLOYEE OF ANY INDEMNITEE, TO THE FULLEST EXTENT PERMITTED BY LAW, LICENSEE SHALL, AND SHALL CAUSE ITS CONTRACTOR TO, RELEASE, INDEMNIFY, DEFEND, AND HOLD THE INDEMNITEES HARMLESS FROM AND AGAINST ANY LIABILITIES ARISING OUT OF OR RELATED TO (IN WHOLE OR IN PART) ANY SUCH ASSERTION INCLUDING, BUT NOT LIMITED TO, ASSERTIONS OF EMPLOYMENT BY AN INDEMNITEE RELATED TO THE FOLLOWING OR ANY PROCEEDINGS THEREUNDER: THE FEDERAL EMPLOYERS' LIABILITY ACT, THE SAFETY APPLIANCE ACT, THE LOCOMOTIVE INSPECTION ACT, THE OCCUPATIONAL SAFETY AND HEALTH ACT, THE RESOURCE CONSERVATION AND RECOVERY ACT, AND ANY SIMILAR STATE OR FEDERAL STATUTE.**
- 13.5 **THE FOREGOING OBLIGATIONS OF LICENSEE SHALL NOT APPLY TO THE EXTENT LIABILITIES ARE PROXIMATELY CAUSED BY THE GROSS NEGLIGENCE OR WILLFUL MISCONDUCT OF ANY INDEMNITEE, BUT SHALL APPLY TO ALL OTHER LIABILITIES, INCLUDING THOSE ARISING FROM OR ATTRIBUTED TO ANY OTHER ALLEGED OR ACTUAL NEGLIGENCE, INTENTIONAL ACTS, OR STRICT LIABILITY OF ANY INDEMNITEE.**
- 13.6 **Upon written notice from Licensor, Licensee agrees to assume the defense of any lawsuit or other proceeding brought against any Indemnitee by any entity, relating to any matter**

covered by this License for which Licensee has an obligation to assume liability for and/or save and hold harmless any Indemnitee. Licensee shall pay all costs and expenses incident to such defense, including, but not limited to, reasonable attorneys' fees, investigators' fees, litigation and appeal expenses, settlement payments, and amounts paid in satisfaction of judgments.

14. Personal Property Risk of Loss. **ALL PERSONAL PROPERTY, INCLUDING, BUT NOT LIMITED TO, FIXTURES, EQUIPMENT, OR RELATED MATERIALS UPON THE PREMISES WILL BE AT THE RISK OF LICENSEE ONLY, AND NO INDEMNITEE WILL BE LIABLE FOR ANY DAMAGE THERETO OR THEFT THEREOF, WHETHER OR NOT DUE IN WHOLE OR IN PART TO THE NEGLIGENCE OF ANY INDEMNITEE.**

15. Insurance. Licensee shall, at its sole cost and expense, procure and maintain during the term of this License the following insurance coverage:

15.1 Commercial General Liability "CGL" Insurance.

a. The policy will provide a minimum of \$2,000,000 per occurrence and an aggregate limit of at least \$4,000,000 but in no event will the coverage be in an amount less than the amount otherwise carried by Licensee. Coverage must be purchased on a post 2004 ISO occurrence form or equivalent and include coverage for, but not limited to, the following:

- Bodily Injury and Property Damage
- Personal Injury and Advertising Injury
- Fire legal liability
- Products and completed operations
- Contractual Liability for an "Insured Contract" consistent with the definition under the standard ISO general liability policy form.

a. This policy will include the following endorsements or language, which shall be indicated on or attached to the certificate of insurance:

- The definition of "Insured Contract" will be amended to remove any exclusion or other limitation for any work being done within 50 feet of Licensor's property;
- Waiver of subrogation in favor of and acceptable to Licensor;
- Additional insured endorsement in favor of and acceptable to Licensor and Jones Lang LaSalle Brokerage, Inc. to include coverage for ongoing operations and completed operations;
- Separation of insureds; and
- The policy shall be primary and non-contributing with respect to any insurance carried by Licensor.

b. The parties agree that the workers' compensation and employers' liability related exclusions in the CGL policy(s) are intended to apply to employees of the policyholder and will not apply to Licensor's employees.

c. No other endorsements that limit coverage with respect to Licensee's obligations under this agreement may be included on the policy.

15.2 Business Automobile Insurance.

a. The insurance will provide minimum coverage with a combined single limit of at least \$1,000,000 per accident, and include coverage for, but not limited to the following:

- Bodily injury and property damage.
- Any and all vehicles owned, used or hired.

- a. The policy will include the following endorsements or language, which will be indicated on or attached to the certificate of insurance:
 - Waiver of subrogation in favor of and acceptable to Licensor;
 - Additional insured endorsement in favor of and acceptable to Licensor;
 - Separation of insureds;
 - The policy shall be primary and non-contributing with respect to any insurance carried by Licensor.

15.3 Workers' Compensation and Employers' Liability Insurance.

- a. The policy will provide coverage of all employees performing any part of the installation or maintenance of the Trail including coverage for, but not limited to:
 - Licensee's statutory liability under the workers' compensation laws of the state(s) in which the work or services under this agreement are to be performed. The policy will cover all of Licensee's employees, regardless of whether such coverage is optional under the law of that state(s).
 - Employers' Liability (Part B) with limits of at least \$500,000 each accident, \$500,000 by disease policy limit, \$500,000 by disease each employee.
- a. The policy will include contain the following endorsements or language, which shall be indicated on or attached to the certificate of insurance:
 - Waiver of subrogation in favor of and acceptable to Licensor.

15.4 Railroad Protective Liability Insurance. The policy will name only Licensor as the Insured and will provide coverage of at least \$2,000,000 per occurrence and \$6,000,000 in the aggregate. The coverage obtained under this policy shall only be effective during the initial installation and/or construction of the Trail. **THE CONSTRUCTION OF THE TRAIL SHALL BE COMPLETED WITHIN ONE (1) YEAR OF THE EFFECTIVE DATE.** If further maintenance of the Trail is needed at a later date, an additional Railroad Protective Liability Insurance Policy shall be required. The policy will be issued on a standard ISO form CG 00 35 12 04 and include the following:

- Endorsed to include the Pollution Exclusion Amendment.
- Endorsed to include the Limited Seepage and Pollution Endorsement.
- Endorsed to remove any exclusion for punitive damages.
- Endorsed to include Evacuation Expense Coverage Endorsement.
- No other endorsements restricting coverage may be added.
- The original policy must be provided to Licensor and Licensee shall not perform any work or services of any kind under this agreement until Licensor has reviewed and approved the policy.
- The definition of "Physical Damage to Property" will be endorsed to read: "means direct and accidental loss of or damage to all property owned by any named insured and all property in any named insured's care, custody and control (including, but not limited to rolling stock and their contents, mechanical construction equipment or motive power equipment, railroad tracks, roadbeds, catenaries, signals, tunnels, bridges and buildings) arising out of the acts or omissions of the contractor named on the Declarations."

In lieu of providing a Railroad Protective Liability Policy, for a period of one (1) year from the Effective Date, Licensee may participate in Licensor's Blanket Railroad Protective Liability Insurance Policy available to Licensee or its contractor. The limits of coverage are the same as above. The cost is \$798.00.

- License may **elect** to participate in Licensor's Blanket Policy;
- Licensee **declines** to participate in Licensor's Blanket Policy.

15.5 Other Requirements:

- 15.5.1 Where allowable by law, no exclusion for punitive damages may be included in any policy.
- 15.5.2 Licensee agrees to waive its right of recovery against Licensor for all claims and suits against Licensor. In addition, Licensee's insurers, through the terms of the policy or policy endorsement, waive their right of subrogation against Licensor for all claims and suits. Licensee further waives its right of recovery, and its insurers also waive their right of subrogation against Licensor for loss of Licensee's owned or leased property or property under Licensee's care, custody, or control.
- 15.5.3 Allocated Loss Expense, including but not limited to defense costs and expenses, will be in addition to all policy limits for coverage under the insurance requirements.
- 15.5.4 Licensee is not allowed to self-insure without the prior written consent of Licensor. If Licensor allows Licensee to self-insure, Licensee shall directly cover any self-insured retention or other financial responsibility for claims in lieu of insurance. Any and all Licensor liabilities that would otherwise be covered by Licensee's insurance in accordance with the provisions of this agreement, will be covered as if Licensee elected not to include a self-insured retention or other financial responsibility for claims.
- 15.5.5 Prior to entering the Premises or commencing any work related to the installation or subsequent maintenance of the Trail, Licensee shall furnish to Licensor an acceptable certificate(s) of insurance from an authorized representative evidencing the required coverage(s), endorsements, and amendments.
- 15.5.6 Licensee agrees to provide evidence to Licensor that it has the required coverage in place at least annually or in the event of a renewal or material change of coverage.
- 15.5.7 Any insurance policy shall be written by a reputable insurance company acceptable to Licensor or with a current Best's Guide Rating of A- and Class VII or better, and authorized to do business in the state(s) in which the service is to be provided.
- 15.5.8 If the coverage provided by any of the insurance policies required by this agreement is purchased on a "claims made" basis, Licensee hereby agrees to maintain coverage in force for a minimum of three years after expiration, cancellation or termination of this agreement.
- 15.5.9 Licensee agrees to provide evidence to Licensor that it has the required coverage in place at least annually or in the event of a renewal or material change of coverage.
- 15.5.10 Licensee represents that this License has been thoroughly reviewed by Licensee's insurance agent(s)/broker(s), and that Licensee has instructed them to procure the insurance coverage required by this License.
- 15.5.11 Not more frequently than once every five years, Licensor may, at its discretion, reasonably modify the insurance requirements to reflect the then-current risk management practices in the railroad industry and underwriting practices in the insurance industry.
- 15.5.12 If Licensee will subcontract any portion of the operation, Licensee shall require that the subcontractor provide and maintain insurance coverage(s) as set forth herein, naming Licensor as an additional insured. In addition Licensee shall require that the subcontractor shall release, defend and indemnify Licensee to the same extent and

under the same terms and conditions as Licensee is required to release, defend and indemnify Licensor under this agreement.

- 15.5.13 Failure to provide evidence as required by this section shall entitle, but not require, Licensor to terminate this License immediately. Acceptance of a certificate that does not comply with this section shall not operate as a waiver of Licensee's obligations hereunder.
- 15.5.14 The fact that Licensee obtains insurance (including, without limitation, self-insurance) shall not release or diminish Licensee's liabilities or obligations including, without limitation, the liabilities and obligations under the indemnity provisions of the License. Damages recoverable by Licensor shall not be limited by the amount of the required insurance coverage.
- 15.5.15 In the event of a claim or lawsuit involving Licensor arising out of this agreement, Licensee will make the policy covering such claims or lawsuits available to Licensor.
- 15.5.16 If Licensee maintains broader coverage and/or higher limits than the minimum requirements in this Agreement, Licensor requires and shall be entitled to the broader coverage and/or the higher limits. Any available insurance proceeds in excess of the specified minimum limits of insurance and coverage shall be available to Licensor.
- 15.5.17 These insurance provisions are intended to be a separate and distinct obligation on the part of the Licensee. Therefore, these provisions shall be enforceable and Licensee shall be bound thereby regardless of whether or not indemnity provisions are determined to be enforceable in the jurisdiction in which the work or services performed under this License is performed.
- 15.5.18 For purposes of this **Section 15**, Licensor shall mean "Burlington Northern Santa Fe, LLC", "BNSF Railway Company" and the subsidiaries, successors, assigns and affiliates of each.

16. Compliance with Laws, Rules, and Regulations.

- 16.1 Licensee shall observe and comply with any and all laws, statutes, regulations, ordinances, orders, covenants, restrictions, or decisions of any court of competent jurisdiction ("**Legal Requirements**") relating to the construction, maintenance, and use of the Trail and the use of the Premises.
- 16.2 Prior to entering the Premises, Licensee shall and shall cause its contractor(s) to comply with all Licensor's applicable safety rules and regulations. Licensee must ensure that each of its employees, contractors, agents or invitees entering upon the Premises completes the safety orientation program at the website www.BNSFcontractor.com (the "**Safety Orientation**") within one (1) year prior to entering upon the Premises. Additionally, Licensee must ensure that each and every employee of Licensee, its contractors, agents and invitees possess a card certifying completion of the Safety Orientation prior to entering upon the Premises. Licensee must renew the Safety Orientation annually.
- 16.3 Licensee shall obtain on or before the date it or its contractor enters the Premises, any and all additional rights-of way, easements, licenses and other agreements relating to the grant of rights and interests in and/or access to the Premises (collectively, the "**Rights**") and such other rights, licenses, permits, authorizations, and approvals (including without limitation, any necessary local, state, federal or tribal authorizations and environmental permits) that are necessary in order to permit Licensee to construct, maintain, own and operate the Trail and

otherwise to perform its obligations hereunder in accordance with the terms and conditions hereof.

- 16.4 Licensee shall either require that the initial stated term of each such Rights be for a period that does not expire, in accordance with its ordinary terms, prior to the last day of the term of this License or, if the initial stated term of any such Right expires in accordance with its ordinary terms on a date earlier than the last day of the term of this License, Licensee shall, at its cost, exercise any renewal rights thereunder, or otherwise acquire such extensions, additions and/or replacements as may be necessary, in order to cause the stated term thereof to be continued until a date that is not earlier than the last day of the term of this License.
- 16.5 Upon the expiration or termination of any Right that is necessary in order for Licensee to own, operate or use the Trail in accordance with the terms and conditions of this License, this License thereby shall automatically expire upon such expiration or termination of the Right.
- 16.6. While this License is personal to Licensee and its invitees, it is recognized that the Trail may be used by unauthorized persons, and Licensee agrees that for the purposes of this License all persons using the Trail shall be deemed the agents or invitees of Licensee.
17. Environmental.
- 17.1 Licensee shall strictly comply with all federal, state and local environmental Legal Requirements and regulations in its use of the Premises, including, but not limited to, the Resource Conservation and Recovery Act, as amended (RCRA), the Clean Water Act, the Oil Pollution Act, the Hazardous Materials Transportation Act, and CERCLA (collectively referred to as the "**Environmental Laws**"). Licensee shall not maintain a treatment, storage, transfer or disposal facility, or underground storage tank, as defined by Environmental Laws on the Premises. Licensee shall not release or suffer the release of oil or hazardous substances, as defined by Environmental Laws on or about the Premises.
- 17.2 Licensee covenants that it will not handle or transport "hazardous waste" or "hazardous substances", as "hazardous waste" and "hazardous substances" may now or in the future be defined by any federal, state, or local governmental agency or body through the Trail on Licensor's property. Licensee agrees periodically to furnish Licensor with proof, satisfactory to Licensor that Licensee is in compliance with the provisions of this **Section 17.2**.
- 17.3 Licensee shall give Licensor immediate notice to Licensor's Resource Operations Center at (800) 832-5452 of any known (i) release of hazardous substances on, from, or affecting the Premises, (ii) violation of Environmental Laws, or (iii) inspection or inquiry by governmental authorities charged with enforcing Environmental Laws with respect to Licensee's use of the Premises. Licensee shall use the best efforts to promptly respond to any release on or from the Premises. Licensee also shall give Licensor immediate notice of all measures undertaken on behalf of Licensee to investigate, remediate, respond to or otherwise cure such release or violation.
- 17.4 If Licensor has notice from Licensee or otherwise of a release or violation of Environmental Laws arising in any way with respect to the Trail which occurred or may occur during the term of this License, Licensor may require Licensee, at Licensee's sole risk and expense, to take timely measures to investigate, remediate, respond to or otherwise cure such release or violation affecting the Premises or Licensor's right-of-way.
- 17.5 Licensee shall promptly report to Licensor in writing any conditions or activities upon the Premises known to Licensee which create a risk of harm to persons, property or the environment and shall take whatever action is necessary to prevent injury to persons,

property or the environment arising out of such conditions or activities; provided, however, that Licensee's reporting to Licensor shall not relieve Licensee of any obligation whatsoever imposed on it by this License. Licensee shall promptly respond to Licensor's request for information regarding said conditions or activities.

DISCLAIMER OF WARRANTIES

18. No Warranties.

18.1 **LICENSOR'S DUTIES AND WARRANTIES ARE LIMITED TO THOSE EXPRESSLY STATED IN THIS LICENSE AND SHALL NOT INCLUDE ANY IMPLIED DUTIES OR IMPLIED WARRANTIES, NOW OR IN THE FUTURE. NO REPRESENTATIONS OR WARRANTIES HAVE BEEN MADE BY LICENSOR OTHER THAN THOSE CONTAINED IN THIS LICENSE. LICENSEE HEREBY WAIVES ANY AND ALL WARRANTIES, EXPRESS OR IMPLIED, WITH RESPECT TO THE PREMISES OR WHICH MAY EXIST BY OPERATION OF LAW OR IN EQUITY, INCLUDING, WITHOUT LIMITATION, ANY WARRANTY OF MERCHANTABILITY, HABITABILITY OR FITNESS FOR A PARTICULAR PURPOSE.**

18.2 **LICENSOR MAKES NO WARRANTY, REPRESENTATION OR CONDITION OF ANY KIND, EXPRESS OR IMPLIED, CONCERNING (A) THE SCOPE OF THE LICENSE OR OTHER RIGHTS GRANTED HEREUNDER TO LICENSEE OR (B) WHETHER OR NOT LICENSEE'S CONSTRUCTION, MAINTENANCE, OWNERSHIP, USE OR OPERATION OF THE TRAIL WILL VIOLATE OR INFRINGE UPON THE RIGHTS, INTERESTS AND ESTATES OF THIRD PARTIES, INCLUDING, WITHOUT LIMITATION, ANY LEASES, USE RIGHTS, EASEMENTS AND LIENS OF ANY THIRD PARTY.**

19. Disclaimer of Warranty for Quiet Enjoyment. **LICENSOR DOES NOT WARRANT ITS TITLE TO THE PREMISES NOR UNDERTAKE TO DEFEND LICENSEE IN THE PEACEABLE POSSESSION OR USE THEREOF. NO COVENANT OF QUIET ENJOYMENT IS MADE.**

20. Eviction at Risk of Licensee. In case of the eviction of Licensee by anyone owning, claiming title to, or claiming any interest in the Premises, or by the abandonment by Licensor of the affected rail corridor, Licensor shall not be liable (i) to refund Licensee any compensation paid hereunder, except for the pro-rata part of any recurring charge paid in advance, or (ii) for any damage Licensee sustains in connection with the eviction.

LIENS AND TAXES

21. Liens and Charges. Licensee shall promptly pay and discharge any and all liens arising out of any construction, alterations or repairs done, suffered or permitted to be done by Licensee on Premises. Licensor is hereby authorized to post any notices or take any other action upon or with respect to Premises that is or may be permitted by law to prevent the attachment of any such liens to Premises; provided, however, that failure of Licensor to take any such action shall not relieve Licensee of any obligation or liability under this **Section 21** or any other Section of this License.

22. Taxes. Licensee shall pay when due any taxes, assessments or other charges (collectively, "**Taxes**" levied or assessed by any governmental or quasi-governmental body upon the Trail or any other improvements constructed or installed on the Premises by or for Licensee (collectively, the "**Improvements**") or any Taxes levied or assessed against Licensor or the Premises that are attributable to the Improvements.

DEFAULT, TERMINATION, AND SURRENDER

23. Default and Termination. In addition to and not in limitation of Licensor's right to terminate for failure

to provide evidence of insurance as required pursuant to the terms of **Section 15**, the following events are also deemed to be events of default pursuant to which Licensor has the right to terminate as set forth below:

- 23.1 If default shall be made in any of Licensee's covenants, agreements, or obligations contained in this License and Licensee fails to cure said default within thirty (30) days after written notice is provided to Licensee by Licensor, or in case of any assignment or transfer of this License in violation of **Section 26** below, Licensor may, at its option, terminate this License by serving five (5) days' notice in writing upon Licensee. Notwithstanding the foregoing, Licensor shall have the right to terminate this License immediately if Licensee fails to provide evidence of insurance as required in **Section 15**.
- 23.2 Should Licensee not comply fully with the obligations of **Section 17** regarding the handling or transporting of hazardous waste or hazardous material, notwithstanding anything contained in any other provision of this License, Licensor may, at its option, terminate this License by serving five (5) days' notice of termination upon Licensee.
- 23.3 Any waiver by Licensor of any default or defaults shall not constitute a waiver of the right to terminate this License for any subsequent default or defaults, nor shall any such waiver in any way affect Licensor's ability to enforce any Section of this License. The remedies set forth in this **Section 23** shall be in addition to, and not in limitation of, any other remedies that Licensor may have at law or in equity.
- 23.4 In addition to and not in limitation of Licensor's rights to terminate this License for failure to provide evidence of insurance or occurrence of defaults as described above, this License may be terminated by either party, at any time, by serving thirty (30) days' written notice of termination upon the other party. Such termination shall not release either party hereto from any liability or obligation under the License, whether of indemnity or otherwise, resulting from any acts, omissions or events happening prior to the date of termination or thereafter in case by the terms of the License it is provided that anything shall or may be done after termination hereof.

24. Surrender of the Premises.

- 24.1 On or before expiration or termination of this License for any reason, Licensee shall, at its sole cost and expense:
 - 24.1.1 if so directed by Licensor in writing, remove the Improvements;
 - 24.1.2 report and restore any damage to the Premises or Licensor's other property arising from, growing out of, or connected with Licensee's use of the Premises;
 - 24.1.3 remedy any unsafe conditions on the Premises created or aggravated by Licensee; and
 - 24.1.4 leave the Premises in substantially the condition which existed as of the Effective Date.
- 24.2 Upon any expiration or termination of this License, if Licensee fails to surrender the Premises to Licensor or if Licensee fails to complete its obligations under **Section 24.1** above (the "**Restoration Obligations**"), Licensee shall have a limited license to enter upon the Premises solely to the extent necessary for Licensee to complete the Restoration Obligations, and all liabilities and obligations of Licensee hereunder shall continue in effect until the Premises are surrendered and the Restoration Obligations are completed. Neither termination nor expiration shall release Licensee from any liability or obligation under this License, whether of indemnity or otherwise, resulting from any acts, omissions or events

happening prior to the date of termination, or, if later, the date when Licensee surrenders the Premises and all of the Restoration Obligations are completed.

- 24.3 If Licensee fails to complete the Restoration Obligations within thirty (30) days after the date of such termination of its tenancy, then Licensor may, at its election, either: (i) remove the Trail and the other Improvements or otherwise restore the Premises, and in such event Licensee shall, within thirty (30) days after receipt of bill therefor, reimburse Licensor for cost incurred, (ii) upon written notice to Licensee, take and hold the Trail and the other Improvements and personal property as its sole property, without payment or obligation to Licensee therefor, or (iii) specifically enforce Licensee's obligation to restore and/or pursue any remedy at law or in equity against Licensee for failure to so restore. Further, if Licensor has consented to the Trail and the other Improvements remaining on the Premises following termination, Licensee shall, upon request by Licensor, provide a bill of sale in a form acceptable to Licensor conveying the Trail and the other Improvements to Licensor for no additional consideration.

MISCELLANEOUS

25. Successors and Assigns. All provisions contained in this License shall be binding upon, inure to the benefit of, and be enforceable by the respective successors and assigns of Licensor and Licensee to the same extent as if each such successor and assign was named a party to this License.
26. Assignment.
- 26.1 Licensee may not sell, assign, transfer, or hypothecate this License or any right, obligation, or interest herein (either voluntarily or by operation of law, merger, or otherwise) without the prior written consent of Licensor, which consent may not be unreasonably withheld or delayed by Licensor. Any attempted assignment by Licensee in violation of this **Section 26** shall be a breach of this License and, in addition, shall be voidable by Licensor in its sole and absolute discretion.
- 26.2 For purposes of this **Section 26**, the word "assign" shall include without limitation (a) any sale of the equity interests of Licensee following which the equity interest holders of Licensee immediately prior to such sale own, directly or indirectly, less than 50% of the combined voting power of the outstanding voting equity interests of Licensee, (b) any sale of all or substantially all of the assets of (i) Licensee and (ii) to the extent such entities exist, Licensee's parent and subsidiaries, taken as a whole, or (c) any reorganization, recapitalization, merger or consolidation involving Licensee. Notwithstanding the foregoing, any reorganization, recapitalization, merger or consolidation following which the equity interest holders of Licensee immediately prior to such reorganization, recapitalization, merger or consolidation own, directly or indirectly, at least 50% of the combined voting power of the outstanding voting equity interests of Licensee or any successor thereto or the entity resulting from such reorganization, recapitalization, merger or consolidation shall not be deemed an assignment. THIS LICENSE SHALL NOT RUN WITH THE LAND WITHOUT THE EXPRESS WRITTEN CONSENT OF LICENSOR, SUCH CONSENT TO BE IN LICENSOR'S SOLE DISCRETION.
- 26.3 Notwithstanding the provisions of **Section 26.1** above or anything contained in this License to the contrary, if Licensee sells, assigns, transfers, or hypothecates this License or any interest herein in contravention of the provisions of this License (a "**Purported Assignment**") to another party (a "**Purported Transferee**"), the Purported Transferee's enjoyment of the rights and privileges granted under this License shall be deemed to be the Purported Transferee's agreement to be bound by all of the terms and provisions of this License, including but not limited to the obligation to comply with the provisions of **Section 15** above concerning insurance requirements. In addition to and not in limitation of the foregoing, Licensee, for itself, its successors and assigns, shall indemnify, defend and hold

harmless Licensor for all Liabilities of any nature, kind or description of any person or entity directly or indirectly arising out of, resulting from or related to (in whole or in part) a Purported Assignment.

- 26.4 The provisions of this **Section 26** shall survive the expiration or earlier termination of this License.
27. Notices. Any notice, invoice, or other writing required or permitted to be given hereunder by one party to the other shall be in writing and the same shall be given and shall be deemed to have been served and given if (i) placed in the United States mail, certified, return receipt requested, or (ii) deposited into the custody of a nationally recognized overnight delivery service, addressed to the party to be notified at the address for such party specified below, or to such other address as the party to be notified may designate by giving the other party no less than thirty (30) days' advance written notice of such change in address.
- If to Licensor: Jones Lang LaSalle Brokerage, Inc.
2650 Lou Menk Drive – MOB2
Fort Worth, TX 76131
Attn: Permits/Licenses
- with a copy to: BNSF Railway Company
2650 Lou Menk Dr.
Fort Worth, TX 76131-2830
Attn: Senior Manager Real Estate
- If to Licensee: City of Duluth
411 W 1st Street
Duluth, MN 55802
28. Survival. Neither termination nor expiration will release either party from any liability or obligation under this License, whether of indemnity or otherwise, resulting from any acts, omissions or events happening prior to the date of termination or expiration, or, if later, the date when the Trail and the other Improvements are removed and the Premises are restored to its condition as of the Effective Date.
29. Recordation. It is understood and agreed that this License shall not be placed or allowed to be placed on public record.
30. Applicable Law. All questions concerning the interpretation or application of provisions of this License shall be decided according to the substantive laws of the State of Texas without regard to conflicts of law provisions.
31. Severability. To the maximum extent possible, each provision of this License shall be interpreted in such manner as to be effective and valid under applicable law, but if any provision of this License shall be prohibited by, or held to be invalid under, applicable law, such provision shall be ineffective solely to the extent of such prohibition or invalidity, and this shall not invalidate the remainder of such provision or any other provision of this License.
32. Integration. This License is the full and complete agreement between Licensor and Licensee with respect to all matters relating to Licensee's use of the Premises, and supersedes any and all other agreements between the parties hereto relating to Licensee's use of the Premises as described herein. However, nothing herein is intended to terminate any surviving obligation of Licensee or Licensee's obligation to defend and hold Licensor harmless in any prior written agreement between the parties.

33. Joint and Several Liability. If Licensee consists of two or more parties, all the covenants and agreements of Licensee herein contained shall be the joint and several covenants and agreements of such parties.
34. Waiver. The waiver by Licensor of the breach of any provision herein by Licensee shall in no way impair the right of Licensor to enforce that provision for any subsequent breach thereof.
35. Interpretation.
- 35.1 This License shall be interpreted in a neutral manner, and not more strongly for or against any party based upon the source of the draftsmanship; both parties hereby agree that this License shall not be subject to the principle that a contract would be construed against the party which drafted the same. Article titles, headings to sections and paragraphs and the table of contents (if any) are inserted for convenience of reference only and are not intended to be a part or to affect the meaning or interpretation hereof. The exhibit or exhibits referred to herein shall be construed with and as an integral part of this License to the same extent as if they were set forth verbatim herein.
- 35.2 As used herein, "include", "includes" and "including" are deemed to be followed by "without limitation" whether or not they are in fact followed by such words or words of like import; "writing", "written" and comparable terms refer to printing, typing, lithography and other means of reproducing words in a visible form; references to any person are also to that person's successors and permitted assigns; "hereof", "herein", "hereunder" and comparable terms refer to the entirety hereof and not to any particular article, section, or other subdivision hereof or attachment hereto; references to any gender include references to the masculine or feminine as the context requires; references to the plural include the singular and vice versa; and references to this License or other documents are as amended, modified or supplemented from time to time.
36. Counterparts. This License may be executed in multiple counterparts, each of which shall, for all purposes, be deemed an original but which together shall constitute one and the same instrument, and the signature pages from any counterpart may be appended to any other counterpart to assemble fully executed documents, and counterparts of this License may also be exchanged via email or electronic facsimile machines and any email or electronic facsimile of any party's signature shall be deemed to be an original signature for all purposes.
37. Licensor's Representative. Jones Lang LaSalle Brokerage, Inc. is acting as representative for BNSF Railway Company.

END OF PAGE – SIGNATURE PAGE FOLLOWS

This License has been duly executed by the parties hereto as of the date below each party's signature; to be effective, however, as of the Effective Date.

LICENSOR:

BNSF Railway Company, a Delaware corporation

By: Jones Lang LaSalle Brokerage, Inc.
2650 Lou Menk Drive – MOB2
Fort Worth, TX 76131

By: _____

Name: _____

Title: _____

Date: _____

LICENSEE:

City of Duluth

By: _____

Name: _____

Title: _____

Date: _____

EXHIBIT "A"

SCALE: 1 IN = 100 FT
TWIN CITIES DIV.
LAKES SUBDIV. L.S. 0235 (0028)
DATE: 7/3/2023

SECTION: 13
TOWNSHIP & RANGE:
49N 15W
MERIDIAN: 4PM

TRIM LINE



LEGEND:
 PREMISES
 RIGHT OF WAY LINE
 TRACK

DESCRIPTION:
 2 PARCEL(S) OF LAND CONTAINING A TOTAL OF 4,554 SQ FT.
 (0.1 A.C.) MORE OR LESS SHOWN HATCHED. TO BE USED
 FOR 10' WIDE PAVED PEDESTRIAN TRAIL.

DULUTH
COUNTY OF ST. LOUIS

STATE OF MN

Source: Esri, Maxar, Earthstar Geographics, and the GIS User Community

DRAWN BY: NAF DRAWING NO. 88183

MAP REF. S70712