

# EXHIBIT A

Prepared by the  
Utility Agreements and Permits Unit  
(Payable)  
(\$5,545,317.00)  
(Actual Cost)

S.P. 6982-322 (T.H. 35)  
Location: I-35, I-535 & US 53 in the City of  
Duluth  
Utility Owner: City of Duluth  
MnDOT Agreement Number 1036438  
Amendment Number 1

## **AMENDMENT NUMBER 1** **TO** **AGREEMENT NUMBER 1036438**

This Amendment Number 1 to Agreement Number 1036438 (Amendment) is between the State of Minnesota (State), acting through its Commissioner of Transportation, and City of Duluth, including its agents, contractors, and subcontractors (Utility Owner).

### **RECITALS**

The State plans to let a contract to construct State Project Number 6982-322 (Project) on Trunk Highway Number 35. The Federal Highway Administration (FHWA) identifies the Project as Minnesota Project Number BLD-NHFP I350(129) in its records. The Project is located on, along and adjacent to I-35, I-535 & US 53 in the City of Duluth.

Authorized FHWA officials have approved the Project.

The State and the Utility Owner entered into Agreement Number 1036438 (Original Agreement). Under the Original Agreement, the Utility Owner agreed to relocate a Sanitary Sewer Lift Station, its fixtures and related equipment (Facilities) according to Exhibit A of the Original Agreement. The State agreed to reimburse the Utility Owner for this relocation. The Utility Owner is relocating its Facilities according to the original Agreement.

The estimated relocation cost of the Original Agreement is \$5,085,091.00. Exhibit B, which is attached to the Original Agreement, shows this amount.

The State found that it must perform work on the Project that it had not identified at the time the Original Agreement was executed. This new work will require the Utility Owner to relocate additional Facilities to that in Exhibit A of the Original Agreement will be necessary according to this Amendment.

The parties are willing to amend the Original Agreement as stated below.

## AMENDMENT

Unless otherwise noted, in this amendment, deleted contract terms will be ~~struck out~~ and the added contract terms will be underlined.

### **Revision 1. Article II.A.1.c. is amended to read as follows:**

- c. The plans for the utility work, which are attached to ~~this~~ the Original Agreement as Exhibit A and to this Amendment as Exhibit A1. If any changes must be made to the plans, the Utilities Engineer must approve these changes in writing before the Utility Owner performs the work to qualify for reimbursement;

### **Revision 2. Article IV.B. & C. are amended to read as follows:**

- B. The Utility Owner grants the State the right of immediate entry upon the land described above to construct the Project, as long as the entry does not interfere with the Utility Owner's Facilities, operations, nor the construction of the replacement facilities identified in Exhibit A and A1.
- C. Upon completion of the project, the State shall convey to the City of Duluth lands mutually determined to be necessary for the operation and maintenance of the Sanitary Sewer Lift Station facilities as shown on Exhibit A & A1. The State will retain lands necessary for the construction and maintenance of the support of the highway.

### **Revision 3. Article V.A.1. is amended to read as follows:**

1. Exhibit B, which is attached to ~~this Agreement, is a detailed~~ the Original Agreement, provides an estimated cost of \$5,085,091.00. Exhibit B1, which is attached to this Amendment, provides an estimated cost of \$460,226.00. Both exhibits are detailed, itemized estimates that combine to give the cost of the Utility Owner's relocation work. Actual cost includes all expenses attributable to design engineering and construction relocation work. Reimbursement will be based on the actual costs for work that conforms to Exhibit A & A1. Betterment, increase in value, and salvage value derived from the relocated Facilities will not be included in this reimbursement.

### **Revision 4. Article V.A.2. is amended to read as follows:**

2. The State will pay the Utility Owner for the actual cost the Utility Owner incurs performing its obligations pursuant to this Agreement, in an amount not to exceed ~~\$5,085,091.00~~ \$5,545,317.00, upon receiving:
  - a. All necessary conveyance documents executed by authorized

- officials of the Utility Owner;
- b. Proof that the Facilities have been relocated to the Project Engineer's and Utilities Engineer's satisfaction; and
  - c. One original, signed invoice that is supported by an itemized statement of costs. An authorized representative of the Utility Owner must sign the invoice and submit the final bill to the Utilities Engineer no later than 180 days after completing the work.

**Revision 5. Article X.G. is amended to read as follows:**

- G. *Incorporation of Exhibits:* All exhibits attached to this Agreement and Amendment 1 are incorporated into this Agreement.

**RELATION TO THE ORIGINAL AGREEMENT**

Except as amended herein, the terms and conditions of the Original Agreement remain in full force and effect.

**The remainder of this page was left blank intentionally.**

**CITY OF DULUTH**

The undersigned certify that they have lawfully executed this contract on behalf of the Governmental Unit as required by applicable charter provisions, resolutions, or ordinances.

By: \_\_\_\_\_  
Mayor

Date: \_\_\_\_\_

Attested: \_\_\_\_\_  
City Clerk

Date: \_\_\_\_\_

Approved as to form:

By: \_\_\_\_\_  
City Attorney

Date: \_\_\_\_\_

Countersigned: \_\_\_\_\_  
City Auditor

Date: \_\_\_\_\_

**STATE OF MINNESOTA  
DEPARTMENT OF TRANSPORTATION**

**State Encumbrance Verification**

*Individual certifies that funds have been encumbered as required by Minnesota Statutes §§ 16A.15 and 16C.05.*

By: \_\_\_\_\_

Date: \_\_\_\_\_

Contract Number: \_\_\_\_\_

Order Number: \_\_\_\_\_

**Department of Transportation**

Recommended for Approval:

Approved:

By: \_\_\_\_\_  
District Engineer

By: \_\_\_\_\_  
Director, Office of Land Management

Date: \_\_\_\_\_

Date: \_\_\_\_\_

**Office of Contract Management**

Approved as to Form and Execution:

By: \_\_\_\_\_

Date: \_\_\_\_\_

**Department of Administration**

By: \_\_\_\_\_

Date: \_\_\_\_\_

{This page left blank}



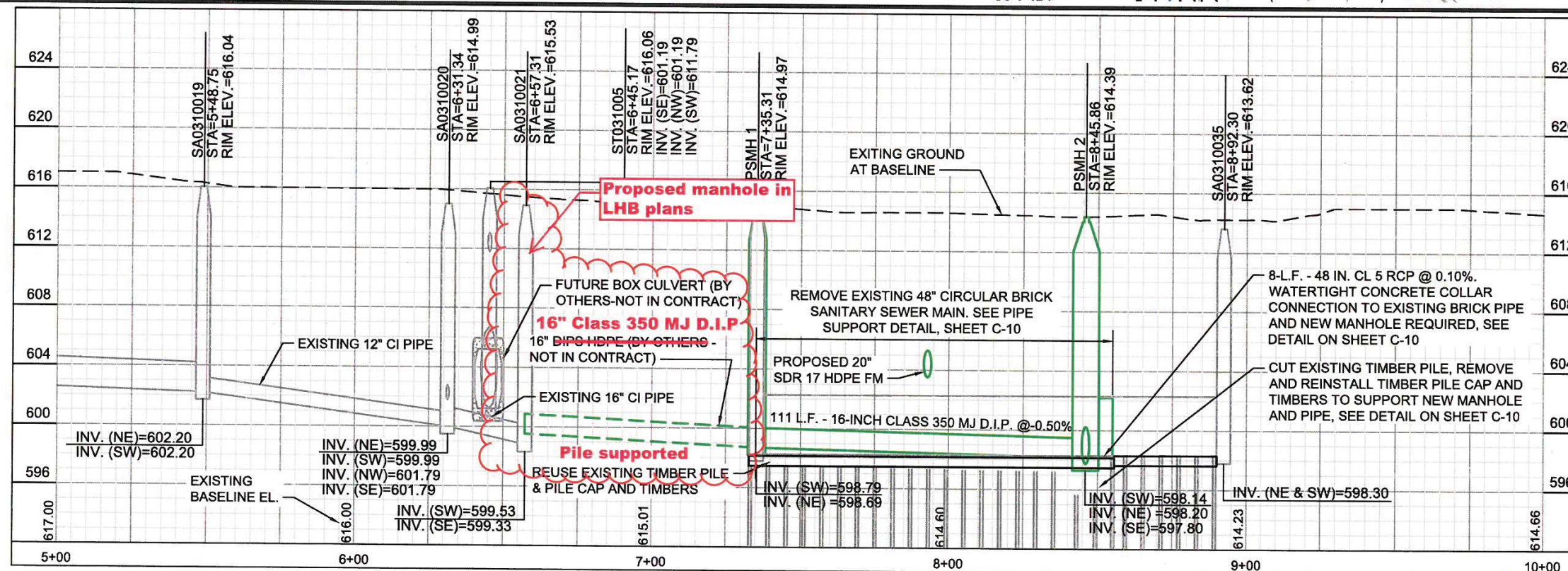
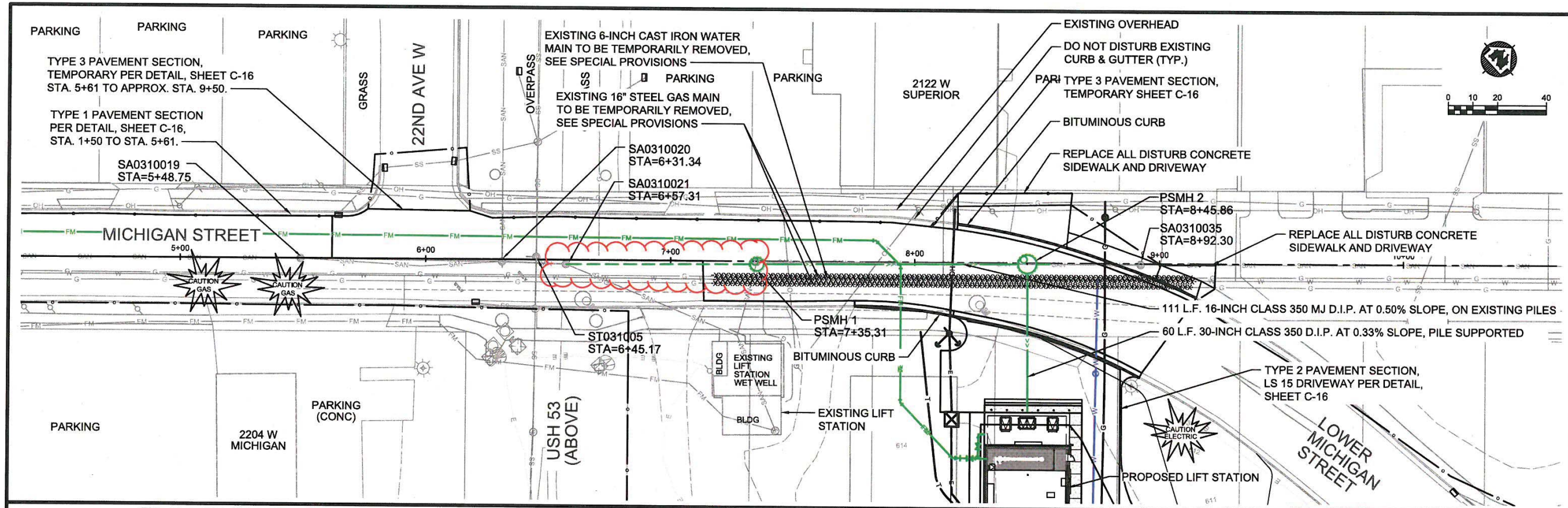

PROJECT NO.: 00616135	SCALE: AS SHOWN	NO.:	DATE:	REVISION:	BY:	HEREBY CERTIFY THAT THIS PLAN, REPORT, OR SPECIFICATION WAS PREPARED BY ME OR UNDER MY DIRECT SUPERVISION AND THAT I AM A DULUTH LICENSED PROFESSIONAL ENGINEER UNDER THE LAWS OF THE STATE OF MINNESOTA.	Date: 1/10/2020 License No.: 44287 Scott R. Carlson	ENGINEERING   ARCHITECTURE   SURVEYING FUNDING   PLANNING   ENVIRONMENTAL 332 W Superior Street, Duluth MN 55802 (218) 722-3915 www.msa-ps.com © MSA Professional Services, Inc.	LIFT STATION 15 RELOCATION CITY OF DULUTH, MINNESOTA 2114 W MICHIGAN STREET	SANITARY PLAN & PROFILE	FILE NO.: 00616135
PROJECT DATE: 1-16-2020	DRAWN BY: SCR	CHECKED BY: SCR					SHEET PP-1				



PLOTTED/REVISED: 4/9/2020

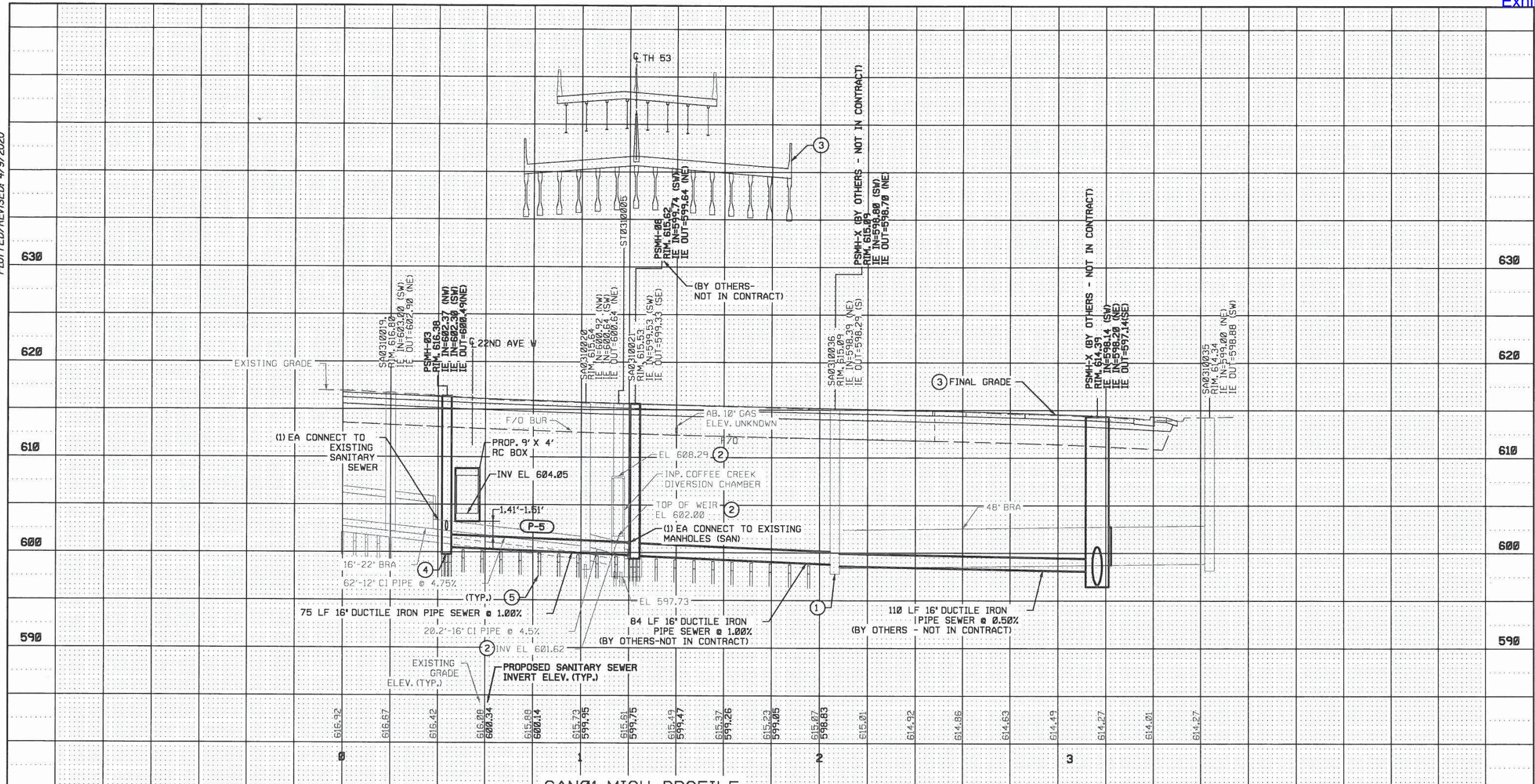

**KEY NOTES:**

- ① NEW MANHOLE TO BE PLACED AT THIS LOCATION UNDER CITY OF DULUTH LIFT STATION PROJECT (BY OTHERS - NOT IN CONTRACT).
- ② ELEVATIONS BASED ON HISTORIC PLAN INFORMATION (VERIFY).
- ③ WORK PACKAGE 2 (WP2) WORK (NOT IN CONTRACT).
- ④ SANITARY SEWER MANHOLE CONCRETE FOOTING AND PILING. SEE MANHOLE CONCRETE FOOTING DETAILS SHT. UA 56.
- ⑤ SANITARY SEWER CONCRETE PEDESTAL AND PILING. SEE SANITARY SEWER CONCRETE PEDESTAL DETAILS SHT. UA 56. CONCRETE PEDESTAL AND PILE SHALL BE SPACED AT 8'-0" ON CENTER (MAX.) BETWEEN MANHOLES AS SHOWN AND DISTANCE FROM EXTERIOR FACE OF MANHOLE TO PILE SHALL BE 4'-0" (MAX.) 17 TOTAL PEDESTALS REQUIRED.

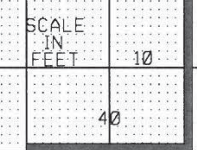

DRAWN BY:	ADB	0	1/13/2020	ADB	MAG	BPS	PLAN LETTING
DESIGNED BY:	ADB						
CHECKED BY:	BPS						
NO		DATE	BY	CKD	APPR	REVISION	

I HEREBY CERTIFY THAT THIS PLAN WAS PREPARED BY ME OR UNDER MY DIRECT SUPERVISION AND THAT I AM A DULY LICENSED PROFESSIONAL ENGINEER UNDER THE LAWS OF THE STATE OF MINNESOTA.

SIGNATURE: \_\_\_\_\_ DATE: 01/13/2020  
 PRINTED NAME: BRAD SCOTT LIC. NO.: 46198



MINNESOTA DEPARTMENT OF TRANSPORTATION  
 MN STATE PROJECT NO: SP 6982-322WP1 (TH 35)

SHEET NO. UA25 OF UA60 SHEETS  
 UTILITY PROFILES  
 W MICHIGAN ST - SANITARY SEWER PROFILE  
 SHEET NO. 77 OF 792 SHEETS



PLOTTED/REVISED: 4/9/2020

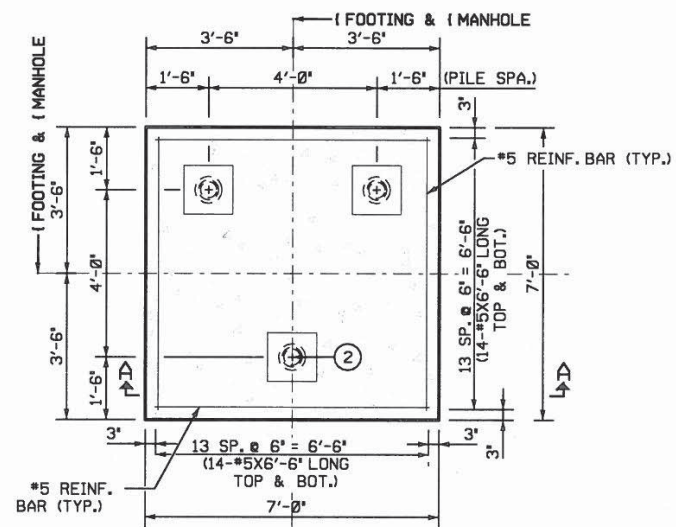

**MANHOLE CONCRETE FOOTING  
 PILE LAYOUT & REINFORCEMENT PLAN**

NOT TO SCALE

**KEY NOTES:**

- ② TYPE 2 ROTARY PILE (TYP.)

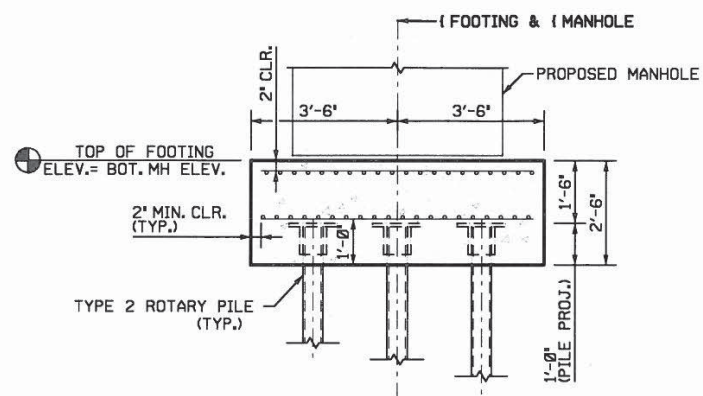

**SECTION A-A  
 SECTION THRU MANHOLE CONCRETE FOOTING**

NOT TO SCALE

**NOTES:**

1. PILING TO BE INCLUDED FOR PAYMENT UNDER ITEM 2452 'ROTARY DRILLED STEEL PILING'.
2. ALL REINFORCING TO BE EPOXY COATED IN ACCORDANCE WITH MNDOT 3301.
3. ALL CONCRETE & REINFORCING TO BE INCLUDED FOR PAYMENT UNDER ITEM 2411 'CONCRETE FOOTING.'
4. CONCRETE FOR FOOTING TO BE MNDOT CONCRETE MIX 1G52.

REQUIRE PILING ULTIMATE (INSTALLED) CAPACITY		
PILE TYPE	LOCATION	ULTIMATE CAPACITY ( TONS/PILE)
TYPE 1	SANITARY SEWER PEDESTALS	18
TYPE 2	MANHOLE CONCRETE FOOTINGS	30

**PILE NOTES:**

1. ALL PILING AND ALL PILING COMPONENTS SHALL BE GALVANIZED IN ACCORDANCE WITH MNDOT 3392 & 3394.
2. ALL PILING SHALL BE PLACED VERTICALLY.
3. SEE ROTARY DRILLED PILE DETAIL (THIS SHEET) FOR PILE DETAILS.
4. ESTIMATED PILE LENGTHS ARE BASED OFF AN ASSUMED PILE TIP ELEVATION OF 57.0. PILE TIP ELEVATION WILL VARY AND WILL BE DETERMINED IN FIELD.
5. SUBMIT ALL PILE COMPONENT AND INSTALLATION DETAILS (INCLUDING METHOD FOR LOAD CAPACITY VERIFICATION) TO ENGINEER FOR APPROVAL PRIOR TO MATERIAL ORDERING OR FABRICATION.

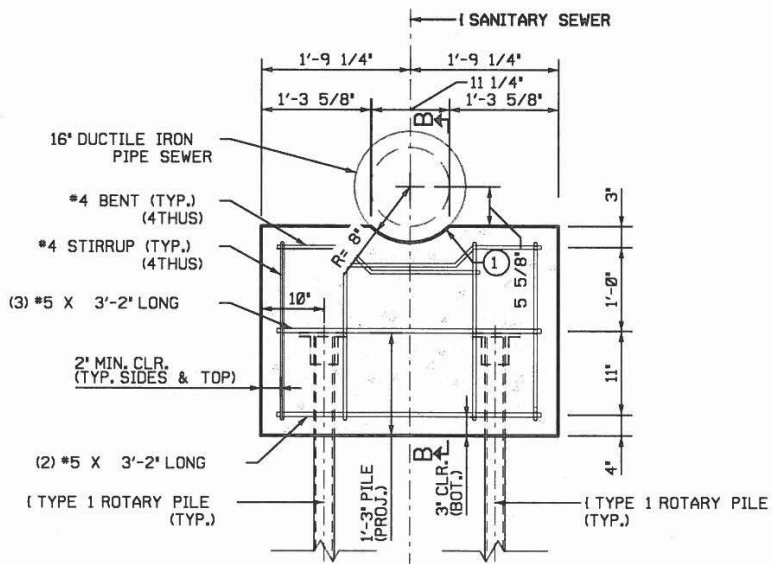
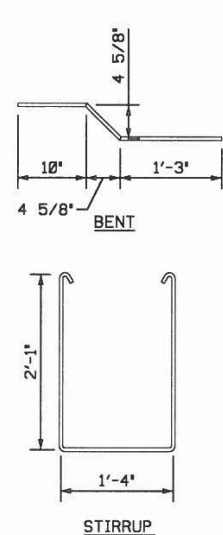

**SANITARY SEWER PEDESTAL ELEVATION**

NOT TO SCALE

**KEY NOTES:**

- ① CONCRETE TO BE FORMED TO MATCH OUTSIDE CIRCUMFERENCE OF NEW SANITARY SEWER PIPE. SEWER PIPE TO BE IN CONTACT WITH PEDESTAL ALONG FULL LENGTH & WIDTH OF PEDESTAL BLOCK OUT EXCEPT AT EDGE CHAMFERS.

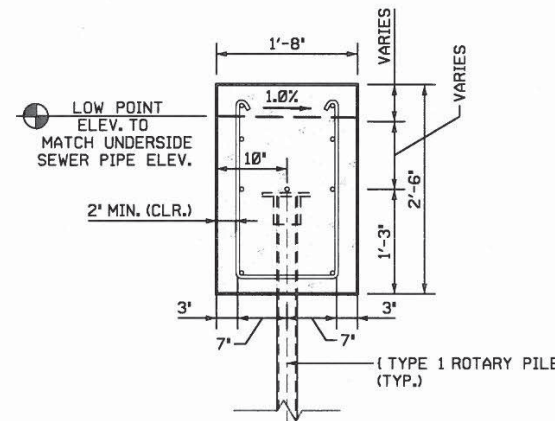

**SECTION B-B  
 SANITARY SEWER PEDESTAL**

NOT TO SCALE

**NOTES:**

1. PILING TO BE INCLUDED FOR PAYMENT UNDER ITEM 2452 'ROTARY DRILLED STEEL PILING'.
2. ALL REINFORCING TO BE EPOXY COATED IN ACCORDANCE WITH MNDOT 3301.
3. CONCRETE FOR PEDESTAL TO BE MNDOT CONCRETE MIX 1G52.
4. ALL CONCRETE & REINFORCING TO BE INCLUDED FOR PAYMENT UNDER ITEM 2411 'PEDESTALS.'

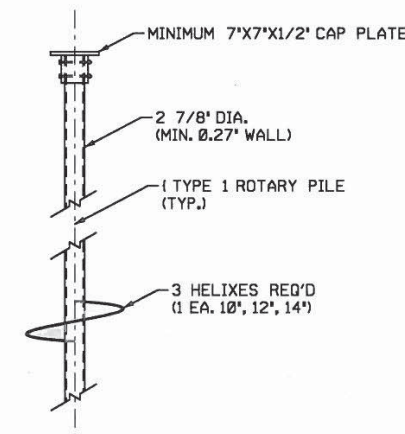

**ROTARY DRILLED PILE DETAIL  
 (PILE TYPES 1 & 2)**

NOT TO SCALE

DRAWN BY: SMH	8	1/13/2020	ADB	MAG	BPS	PLAN LETTING
DESIGNED BY: SMH						
CHECKED BY: BPS	NO	DATE	BY	CKD	APPR	REVISION

PATH & FILENAME: G:\199\ro\190201\600 Drawings\CDetails\190201.dwg

I HEREBY CERTIFY THAT THIS PLAN WAS PREPARED BY ME OR UNDER MY DIRECT SUPERVISION AND THAT I AM A DULY LICENSED PROFESSIONAL ENGINEER UNDER THE LAWS OF THE STATE OF MINNESOTA.

SIGNATURE: \_\_\_\_\_ DATE: 01/13/2020  
 PRINTED NAME: BRAD SCOTT LIC. NO.: 46198



MINNESOTA DEPARTMENT OF TRANSPORTATION

MN STATE PROJECT NO: SP 6982-322WP1 (TH 35)

SHEET NO. UA56 OF UA60 SHEETS

CITY DETAILS

SHEET NO. 108 OF 792 SHEETS

{This page left blank}





**Engineering**

 218-730-5200

Room 240  
411 West First Street  
Duluth, Minnesota 55802

July 7, 2020

Carroll Aasen  
MN/DOT Office of Land Management  
395 John Ireland Blvd. – MS 678  
St. Paul, MN 55155

Re: S.P. 6982-322 (T.H.35) – Twin Ports Interchange  
Lift Station 15 Relocation / DOT Agreement # 1036438  
Revised Request Amendment No. 1 to Agreement to Construct

Dear Mr. Aasen:

In our ongoing coordination with the local MN/DOT (District 1) project staff, it has been determined that a portion of the work originally planned to be constructed by DOT under work package 1 must now be constructed under the City of Duluth's sanitary Lift Station (#15) relocation project. The additional work largely includes the construction of a sewage conveyance pipes in Michigan Street. There is a small portion of this request that includes necessary items that were not identified in the original bid plan.

We request a formal agreement for reimbursement of not only the construction costs, but also reimbursement of the costs of inspection and construction contract administration.

With the added Amendment No. 1 value of \$460,226.00, the total value of the amended utility construction agreement is \$5,545,317.00.

Please contact me at 218-730-5104 or by email at [tpfeffer@duluthmn.gov](mailto:tpfeffer@duluthmn.gov) to answer your questions.

Sincerely,

Tom Pfeffer  
Senior Engineer  
MN licensed PE

Cc: John Krysiak, MNDOT District 1  
Eric Shaffer, Chief Engineer of Utilities  
Aaron Soderlund, Project Engineer  
City Project No. 1803 File



July 7, 2020

TO: Aaron Soderlund  
City of Duluth  
Project Manager  
411 W. First Street, Room 211  
Duluth, MN 55802

RE: Duluth Lift Station 15 Relocation  
City Project Number: 1803

Subject: Change Order #1

Dear Aaron,

Please see summary below outlining costs associated with Change Order #1.

- |                                       |              |
|---------------------------------------|--------------|
| 1. COP#1 – 16" MJ Gate Vale Spur Gear | \$3,101.00   |
| 2. COP#4 – Added Street Utility Work  | \$448,247.00 |
| 3. COP#5 – Grinder Material Increase  | \$8,878.00   |

TOTAL: \$460,226.00

Sincerely,

RICE LAKE CONSTRUCTION GROUP

Mark Hinsz  
Project Manager

cc: File

22360 County Road 12  
PO Box 517  
Deerwood, MN 56444  
PH 218-546-5519  
FX 218-546-7016





PROJECT NAME Duluth L15 Relocation  
 RLCG PROJECT NO. 2011

Change Order Proposal 1  
 Date: 6/18/2020  
 Reference: 16" MJ Gate Valve Spur Gear

**CONSTRUCTION ESTIMATE**

DESCRIPTION	QTY	UNIT	LABOR			MATERIAL		SUB	EQUIP.	LINE
			RATE	HOURS	\$ RATE	TOTAL	RATE	TOTAL	TOTAL	TOTAL
P&F Proposal	1.0	LS		0.00	\$0.00	\$0.00		\$0.00	\$0.00	\$0.00
				0.00	\$0.00	\$0.00	\$2,455.00	\$2,455.00	\$0.00	\$0.00
				0.00	\$0.00	\$0.00		\$0.00	\$0.00	\$0.00
Misc Small Tools and Materials	1.0	ls		0.00	\$0.00	\$0.00	\$0.00	\$0.00	\$0.00	\$0.00
5% of labor				0.00	\$0.00	\$0.00		\$0.00	\$0.00	\$0.00
					\$0.00	\$0.00		\$0.00	\$0.00	\$0.00
Sales Tax	1.0	ls	8.8750%	0.09	\$0.00	\$0.00	\$217.88	\$217.88	\$0.00	\$0.00
				0.00	\$0.00	\$0.00		\$0.00	\$0.00	\$0.00
	0			0.00		\$0.00		\$2,672.88	\$0.00	\$0.00
									\$0.00	\$0.00
										\$400.93
										\$26.73
										\$3,101

Rice Lake Mark-up on Subs-5% \$0.00  
 Rice Lake Mark-up @ 15% \$400.93  
 Bond Cost @ 1% \$26.73  
**Total Change Order Request \$3,101**

6/16/2020

Mail - Jaime Barry - Outlook

### ADDER FOR SPUR GEAR

**DB** Dustin Bremness <D  
B@plantandflanged.com>  
om>  
Fri 6/12/2020 2:37 PM  
To: Jaime Barry

**Caution:** This email originated from outside the organization. Do not click links or open attachments unless you recognize the sender and know the content is safe.

Adder for the gate valve \$4159.35 each

Thank you,

Dustin Bremness



PLANT AND FLANGED EQUIPMENT, LLC  
Phone: (763) 762-4960  
Cell: (651) 338-5759  
Fax: (763) 792-3876  
Email: [db@plantandflanged.com](mailto:db@plantandflanged.com)

□

**JB** Jaime Barry  
Fri 6/12/2020 1:43 PM  
To: Dustin Bremness <DB@plantandflan

Dustin,

Is it the same price for a 12" as well?

Thanks,

Jaime Barry  
Project Engineer  
Rice Lake Construction Group  
218-546-1907 Office Direct  
218-838-4318 Cell  
218-546-7016 Fax  
[www.ricelake.org](http://www.ricelake.org)

□

**DB** Dustin Bremness <DB@plantandflanged.com>  
Wed 6/17/2020 3:49 AM  
To: Jaime Barry

**Caution:** This email originated from outside the organization. Do not click links or open attachments unless you recognize the sender and know the content is safe.

Includes gear and 316 s.s. valve fasteners

Thank you,  
Dustin Bremness



PLANT AND FLANGED EQUIPMENT, LLC  
Phone: (763) 762-4960  
Cell: (651) 338-5759  
Fax: (763) 792-3876  
Email: [db@plantandflanged.com](mailto:db@plantandflanged.com)

...

**DB** Dustin Bremness <DB@plantandflanged.com>  
Fri 6/12/2020 11:01 AM  
To: Jaime Barry

**Caution:** This email originated from outside the organization. Do not click links or open attachments unless you recognize the sender and know the content is safe.

1 - SPUR GEAR FOR 16" MJ MUELLER R/W GATE VALVE \$2455.00 EACH

Please advise if you would like me to proceed.

Thank you,

Dustin Bremness



PLANT AND FLANGED EQUIPMENT, LLC  
Phone: (763) 762-4960  
Cell: (651) 338-5759  
Fax: (763) 792-3876  
Email: [db@plantandflanged.com](mailto:db@plantandflanged.com)





# SHOP DRAWING REVIEW

**Date Returned:** 6/9/2020  
**Project:** Lift Station # 15 Relocation  
City of Duluth, MN  
**Submittal:** SDR 40 23 23 - 2  
Process Piping, Valves and  
Specialties  
Partial  
**COD Project #:** 1803  
**MSA Project #:** 000616139  
**Review By:** JRG/SRC

SHOP DRAWING REVIEW	
Review is for general compliance with contract documents. No responsibility is assumed for correctness of dimensions or details. Contractor is responsible for approval of shop drawings and for complete compliance with the requirements of the contract documents.	
<input type="checkbox"/> Reviewed - See to comments and conditions as noted	<input checked="" type="checkbox"/> Amend and Resubmit - See Comments as noted
<input type="checkbox"/> Additional Information Required - See Comments as noted	<input type="checkbox"/> Rejected - See comments and conditions as noted
MSA Professional Services, Inc.	

**General SDR Review Comments:**

- A. The supplier, subcontractor, and general contractor are responsible for providing the material and products as identified in the specifications and on the drawings, regardless of what is shown in this submittal. MSA's review of this submittal is cursory. Errors and omissions in this submittal are the responsibility of the supplier and contractor, not the responsibility of MSA.
- B. The contractor shall confirm/verify all sizes, dimensions, orientations, and quantities for installation.
- C. Provide factory testing, equipment start-up, and post start-up visit as specified.
- D. Provide warranties as required by the specification.
- E. All items containing Iron or Steel shall be delivered to the site with compliance certificate with "Buy America" requirements of Federal Regulation CFR 635.410; or shall be itemized under the De Minimis allowance schedule. No item containing Iron or Steel shall be installed or receive payment without complete documentation.

**Reviewed Comments:**

- 1. Gate Valves shall be SS Fitted with SS Stems for use in wastewater.
- 2. Buried valves shall be treated with corrosion treatment system to match COD standards for underground metallic materials. The V-Bio Encasement shall be extended around the valves.
- 3. Please provide proposal to provide 16" MJ GV with Spur Gear with SS fasteners. The installation with the gear actuator may impact the use of the valve box adapter.



June 25, 2020

TO: Aaron Soderlund  
 City of Duluth  
 Project Manager  
 411 W. First Street, Room 211  
 Duluth, MN 55802

RE: Duluth Lift Station 15 Relocation  
 City Project Number: 1803

Subject: COP04 Added Street Utility Work

Dear Aaron,

Please see below the breakdown of unit price costs for the added street utility work. Estimated quantities have been provided to track against existing unit prices established in the contract. Estimated total price of the added work is \$448,247.00.

Item ID	Spec. No.	Description	Est. Quantity	Units	Unit Price	Ext. Price
425737	2104.502	REMOVE SANITARY MANHOLE	1	EA	\$ 12,600.00	\$ 12,600.00
425740	2104.504	REMOVE ASPHALT PAVEMENT	250	SY	\$ 9.00	\$ 2,250.00
425741	2104.601	REMOVE ABANDONED 16" CI GAS MAIN	1	LS	\$ 7,247.00	\$ 7,247.00
425742	2104.603	REMOVE 6" CI WATER MAIN	100	LF	\$ 31.00	\$ 3,100.00
425743	2105.507	SELECT GRANULAR BORROW, (CV) MOD 7%; 12" UNDER ALL NEW PAVEMENT	85	CY	\$ 20.00	\$ 1,700.00
425746	2211.507	AGGREGATE BASE (CV) CLASS V; 8" UNDER ALL NEW PAVEMENT	56	CY	\$ 25.00	\$ 1,400.00
425748	2360.509	TYPE SP 12.5 WEARING COURSE (4, F)	90	TON	\$ 153.00	\$ 13,770.00
425751	2503.502	CONNECT TO EXISTING SEWERS	1	EA	\$ 7,500.00	\$ 7,500.00
425764	2503.602	PIPE CAP AND PILES	10	EA	\$ 29,750.00	\$ 297,500.00
425765	2503.603	16" DI PIPE SEWER - GRAVITY (PRESSURE CLASS 350)	84	LF	\$ 950.00	\$ 79,800.00
425768	2504.603	8" WATER MAIN DUCTILE IRON (CLASS 52)	100	LF	\$ 75.00	\$ 7,500.00
425769	2505.603	16" STEEL HP GAS TRENCH EXCAVATION	100	LF	\$ 42.00	\$ 4,200.00
425770	2506.502	SANITARY SEWER MANHOLE, CONST DRAINAGE STRUCTURE (PSMH-8)	1	LS	\$ 9,680.00	\$ 9,680.00
TOTALS						\$ 448,247.00

The scope of work included with this proposal is as follows:

1. Added piling, pile caps, sanitary manhole and sanitary piping as required. Sanitary sewer bypass pumping system to intercept flows from the west on Michigan Street as required.
2. Added street removals and replacements as required.
3. Temporary water as required. Temporary removals and replacements of gas piping and water piping as required.

22360 County Road 12  
 PO Box 517  
 Deerwood, MN 56444  
 PH 218-546-5519  
 FX 218-546-7016



4. Temporary excavation protection systems as required for the existing Coffee Creek Diversion Chamber and existing MN Power electrical duct bank.
5. Traffic Control modifications as required.
6. Contaminated soils have not been forecast for this additional work as it is unknown what to anticipate for estimated quantities. Contaminated soil removals will be provided at the unit price established with the contract (ID#425744).

Sincerely,

RICE LAKE CONSTRUCTION GROUP

Mark Hinsz  
Project Manager

cc: File

22360 County Road 12  
PO Box 517  
Deerwood, MN 56444  
PH 218-546-5519  
FX 218-546-7016



**Mark Hinsz**

---

**From:** Aaron Soderlund <asoderlund@DuluthMN.gov>  
**Sent:** Wednesday, May 20, 2020 3:49 PM  
**To:** Mark Hinsz  
**Cc:** Scott Chilson; Phil Lockett  
**Subject:** LS15 Change Order 1  
**Attachments:** 190201\_PlotSet\_DRAFT.pdf; 1803 - LS15 Final PP-1.pdf

**Caution:** This email originated from outside the organization. Do not click links or open attachments unless you recognize the sender and know the content is safe.

Mark,

Attached is latest version of the LHB created City Utility sheets for DOT WP1 plan. The LS project will need to install the manhole noted as "PSMH-08" on LHB's plan sheet UA25 (aka 77 of 792)...PLUS the 84 LF of 16" DUCTILE PIPE running to existing manhole sa0310036 which is shown as NEW MH "PSMH 1" on MSA's plan sheet PP-1 (aka 19 of 75).

While the final invert elevation of the new manhole (PSMH-08) may need to be adjusted in the field, I believe there is enough information in the LHB plans for Rice Lake Construction to provide a cost proposal.

A note: Due to the existing overhead bridge, I believe that Rice Lake (Northland) may need to consider installing "rotary" pile (aka helix) for the pipe support. See LHB sheet UA56 (aka 108 of 792).

In summary, we need to construct the additional gravity sewer to get the new lift station up and running. Here is a summary of the items added to the scope:

- a. One additional 17' sanitary manhole on piling.
- b. 85 feet of pile supported 16" Ductile Iron sanitary sewer pipe (previously in WP1).
- c. Street restoration for approximately 300 +/- feet of Michigan Street.
- d. Temporary removal and re-installation of 180 feet of 16" steel gas main in Michigan.
- e. Temporary water service for several buildings along Michigan Street.
- f. Additional length of water main removal and replacement .
- g. Additional removal and disposal of contaminated soils.

I anticipate there will be questions and some discussion on this change order. This should be enough information to get you and Northland started on putting the costs together.

**Aaron Soderlund, PE** | Project Engineer | **City of Duluth** | 411 W. First Street, Room 211, Duluth, MN 55802 | 218-730-5083 | [asoderlund@duluthmn.gov](mailto:asoderlund@duluthmn.gov)



PROJECT NAME Duluth L15 Relocation  
 RLCG PROJECT NO. 2011

Change Order Proposal 5  
 Date: 6/25/2020  
 Reference: Grinder Material Increase

CONSTRUCTION ESTIMATE

DESCRIPTION	QTY	UNIT	LABOR			MATERIAL		SUB TOTAL	EQUIP. TOTAL	LINE TOTAL	
			RATE	HOURS	\$ RATE	TOTAL	RATE				TOTAL
				0.00	\$0.00	\$0.00		\$0.00	\$0.00	\$0.00	
JWC - Removed Materials	-1.0	LS		0.00	\$0.00	\$0.00	\$13,718.55	-\$13,718.55	\$0.00	\$0.00	-\$13,718.55
NWPE/Franklin Miller - Added Material	1.0	LS		0.00	\$0.00	\$0.00	\$20,748.00	\$20,748.00	\$0.00	\$0.00	\$20,748.00
Misc Small Tools and Materials	1.0	ls		0.00	\$0.00	\$0.00	\$0.00	\$0.00	\$0.00	\$0.00	\$0.00
5% of labor				0.00	\$0.00	\$0.00		\$0.00	\$0.00	\$0.00	\$0.00
Sales Tax	1.0	ls	8.8750%	0.09	\$0.00	\$0.00	\$623.86	\$623.86	\$0.00	\$0.00	\$623.86
				0.00	\$0.00	\$0.00		\$0.00	\$0.00	\$0.00	\$0.00
	0			0.00		\$0.00		\$7,653.31	\$0.00	\$0.00	\$7,653

Rice Lake Mark-up on Subs-5% \$0.00  
 Rice Lake Mark-up @ 15% \$1,148.00  
 Bond Cost @ 1% \$76.53  
**Total Change Order Request \$8,878**

20th 2011-11020



4280 E. 14th St.  
Des Moines, IA 50313  
Office: 515-265-2222  
Toll Free: 800-383-7867  
Fax: 515-265-8079

201 4th Ave SW  
New Prague, MN 56071  
Office: 952-758-6600  
Toll Free: 800-536-5394  
Fax: 952-758-7778

TO: Selected Bidding Contractors

REF: Lift Station #15 Relocation  
Duluth, MN

BID DATE: February 12, 2020 at 2:00PM

ENG: MSA

**Bid Item No. 2503.601 – LS # 15 Construction  
JWCE Appurtenances**

- One (1) JWCE Channel Monster Frame fabricated from 304 SS, flat wall-mounted (for model CDD3216-XDS2.0 Grinder) (Grinder shall be furnished by the owner).
- One (1) JWCE Guide Rail System, flat wall-mounted (13' long) fabricated from 304SS
- One (1) JWCE Grinder Lifting Bail fabricated from 316 SS
- One (1) JWCE Grinder Lifting Chain fabricated from 316 SS
- One (1) Lot of freight to jobsite included

**Total Selling Price: \$13,718.55 plus tax**

**Note the following:**

**Purchase Order shall be directed to:**

- o Ref. Quote #: 53657
- o JWC Environmental *In Care of* Electric Pump
- o 2850 S. Red Hill Ave. Suite 125
- o Santa Ana, CA 92705
- o Fax: 714-242-0240
- o Contact: Jon Kimler
- o Email: [jonk@jwce.com](mailto:jonk@jwce.com)

- The quoted material conform to AIS & BAA.
- Concrete, Anchor bolts, Junction Boxes, Reducers, Valves, Piping, Conduit, Installation of equipment and anything that's not specifically mentioned in this proposal is the responsibility of others

\$14,936.07

Thank you for your consideration,

Jeff Janiksela (612) 867-6219  
cc: Taylor Musselman (515) 265-2222



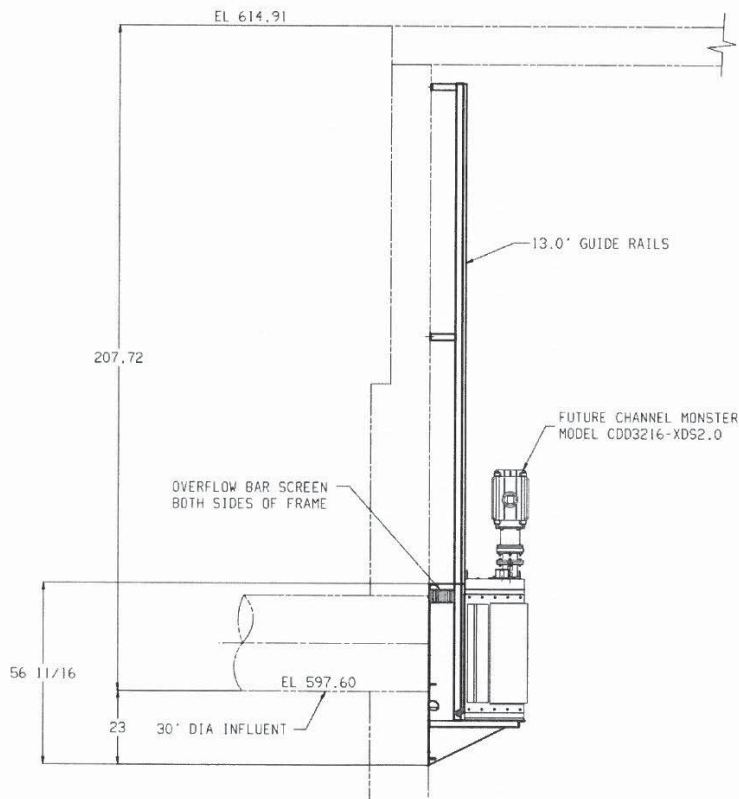
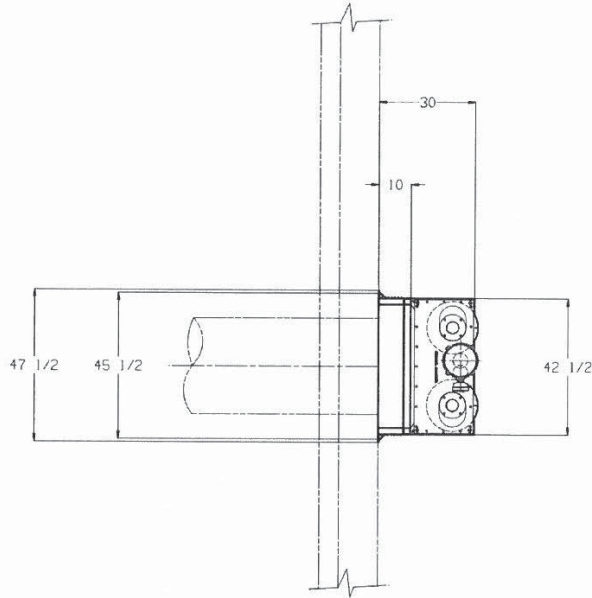

MnDOT S.P. 6982-322 (T.H. 35)  
Agreement Number 1036438  
Amendment Number 1  
Exhibit "B1"



**JWC Environmental**  
2850 S. Red Hill Ave. Suite 125  
Santa Ana, CA 92705  
Phone: 949.833.3888  
Toll Free: 800.331.2277  
Fax: 714.242.0240

Quote # 53657

**JWC ENVIRONMENTAL  
TERMS AND CONDITIONS OF SALE**

Unless otherwise specifically agreed to in writing by the buyer ("Buyer") of the products and/or related services purchased hereunder (the "Products") and JWC Environmental (the "Seller"), the sale of the Products is made only upon the following terms and conditions. Whether these terms are included in an offer or an acceptance by Seller, such offer or acceptance is conditioned on Buyer's assent to these terms. Seller rejects all additional, conditional and different terms in Buyer's form or documents.

**PAYMENT TERMS**

Subject to any contrary terms set forth in our price quotation, order acceptance or invoice the full net amount of each invoice is due and payable in cash within 30 days from the date of the invoice. If any payment is not received within such 30-day period, Buyer shall pay Seller the lesser of 1.5% per month or the maximum legal rate on all amounts not received by the due date of the invoice, from the 31st day after the date of invoice until said invoice and charges are paid in full. Unless Seller documents provide otherwise, freight, storage, insurance and all taxes, duties or other governmental charges related to the Products shall be paid by the Buyer. If Seller is required to pay any such charges, Buyer shall immediately reimburse Seller for said charges. In all cases, regardless of partial payment, title to the Products shall remain the Seller's until payment for the Products has been made in full. All orders are subject to credit approval by Seller. All offers by Seller and/or acceptance of Buyer's order shall be nullified by any failure of Buyer to obtain credit approval. Furthermore, Buyer shall not assert any claim against Seller due to Buyer's inability to obtain credit approval. Irrevocable Letter of Credit from Buyer in form and term acceptable to Seller is required for Product orders delivered outside the United States of America.

**DELIVERY**

Unless otherwise provided in our price quotation, delivery of the Products shall be made F.O.B. place of manufacture. Any shipment, delivery, installation or service dates quoted by the Seller are estimated and the Seller shall be obligated only to use reasonable efforts to meet such dates. The Seller shall in no event be liable for any delays in delivery or failure to give notice of delay or for any other failure to perform hereunder due to causes beyond the reasonable control of the Seller. Such causes shall include, but not be limited to: acts of God, the elements, acts or omissions of manufacturers or suppliers of the Products or parts thereof, acts or omissions of Buyer or civil and military authorities, fires, labor disputes or any other inability to obtain the Products, parts thereof, or necessary power, labor, materials or supplies. The Seller will be entitled to refuse to make, or to delay, any shipments of the Products if Buyer shall fail to pay when due any amount owed by it to the Seller, whether under this or any other contract between the Seller and Buyer. Any claims for shortages must be made to the Company in writing within five calendar days from the delivery date and disposition of the claim is solely subject to Seller's determination.

**PRICES**

Prices of the Seller's Products are subject to change without notice. Quotations are conditioned upon acceptance within 30 days unless otherwise stated and are subject to correction for errors and/or omissions. Prices include charges for regular packaging but, unless expressly stated, do not include charges for special requirements of government or other purchaser. Prices are subject to adjustment should Buyer place order past the validity period of the quotation or delay delivery of Products beyond the quoted lead time for any reason.

**RETURNS**

No Products may be returned for cash. No Product may be returned for credit after delivery to Buyer without Buyer first receiving written permission from the Seller. Buyer must make a request for return of Product in writing to Seller at its place of business in Costa Mesa, California. A return material authorization number must be issued by the Seller to the Buyer before a Product may be returned. Permission to return Product to Seller by Buyer is solely and exclusively the Seller's. Product must be returned to Seller at Buyer's expense, including packaging, insurance, transportation and any governmental fees. Any credit for Product returned to Seller shall be subject to the inspection of and acceptance of the Product by the Seller and is at the sole discretion of the Seller.

**LIMITED WARRANTY**

Subject to the terms and conditions hereof, the Seller warrants until one year after commissioning (written notification to Seller by Buyer required) of the Product or until 18 months after delivery of such Product to Buyer, whichever is earlier, that each Product will be free of defects in material and workmanship. If (a) the Seller receives written notification of such defect during the warranty period and the defective Product use is discontinued promptly upon discovery of alleged defect, and (b) if the owner ("Owner") forwards the Product to the Seller's nearest service/repair facility, transportation and related insurance charges prepaid. The Seller will cause any Products whose defect is covered under this warranty to either be replaced or be repaired at no cost to the Owner. The foregoing warranty does not cover repairs required due to repair or alteration other than by the Seller's personnel, accident, neglect, misuse, transportation or causes other than ordinary use and maintenance in accordance with the Seller's instructions and specifications. In addition, the foregoing warranty does not cover any Products, or components thereof, which are not directly manufactured by the Seller. To the extent a warranty for repair or replacement of such Products or components not manufactured directly by the Seller is available to Buyer under agreements of the Seller with its vendors, the Seller will make such warranties available to Buyer. Costs of transportation of any covered defective item to and from the nearest service/repair center and related insurance will be paid or reimbursed by Buyer. Any replaced Products will become the property of the Seller. Any replacement Products will be warranted only for any remaining term of the original limited warranty period and not beyond that term.

**DISCLAIMER OF WARRANTIES AND LIMITATIONS OF LIABILITIES**

THE SELLER'S FOREGOING LIMITED WARRANTY IS THE EXCLUSIVE AND ONLY WARRANTY WITH RESPECT TO THE PRODUCTS AND SHALL BE IN LIEU OF ALL OTHER WARRANTIES (OTHER THAN THE WARRANTY OF TITLE), EXPRESS, STATUTORY OR IMPLIED, INCLUDING, BUT NOT LIMITED TO, ANY IMPLIED WARRANTIES OF MERCHANTABILITY OR FITNESS FOR A PARTICULAR PURPOSE AND ANY STATEMENTS MADE BY EMPLOYEES, AGENTS OF THE SELLER OR OTHERS REGARDING THE PRODUCTS. THE OBLIGATIONS OF THE SELLER UNDER THE FOREGOING WARRANTY SHALL BE FULLY SATISFIED BY THE REPAIR OR THE REPLACEMENT OF THE DEFECTIVE PRODUCT OR PART, AS PROVIDED ABOVE. IN NO EVENT SHALL THE SELLER BE LIABLE FOR LOST PROFITS OR OTHER SPECIAL, INDIRECT OR CONSEQUENTIAL DAMAGES, EVEN IF THE SELLER HAS BEEN ADVISED OF THE POSSIBILITY OF SUCH DAMAGES. THE TOTAL LIABILITY OF THE SELLER TO BUYER AND OTHERS ARISING FROM ANY CAUSE WHATSOEVER IN CONNECTION WITH BUYER'S PURCHASE, USE AND DISPOSITION OF ANY PRODUCT COVERED HEREBY SHALL UNDER NO CIRCUMSTANCES EXCEED THE PURCHASE PRICE PAID FOR THE PRODUCT BY BUYER. NO ACTION, REGARDLESS OF FORM, ARISING FROM THIS AGREEMENT OR BASED UPON BUYER'S PURCHASE, USE OR DISPOSITION OF THE PRODUCTS MAY BE BROUGHT BY EITHER PARTY MORE THAN ONE YEAR AFTER THE CAUSE OF ACTION ACCRUES, EXCEPT THAT ANY CAUSE OF ACTION FOR THE NONPAYMENT OF THE PURCHASE PRICE MAY BE BROUGHT AT ANY TIME.

The remedies provided to Buyer pursuant to the limited warranty, disclaimer of warranties and limitations of liabilities, described herein are the sole and exclusive remedies.

Unless specifically agreed to in writing by the Seller, no charges may be made to the Seller by Buyer or any third party employed by Buyer for removing, installing or modifying any Product.

The Seller and its representatives may furnish, at no additional expense, data and engineering services relating to the application, installation, maintenance or use of the Products by Buyer. The Seller will not be responsible for, and does not assume any liability whatsoever for, damages of any kind sustained either directly or indirectly by any person through the adoption or use of such data or engineering services in whole or in part.

**CONFIDENTIAL INFORMATION**

Except with the Seller's prior written consent, Buyer shall not use, duplicate or disclose any confidential proprietary information delivered or disclosed by the Seller to Buyer for any purpose other than for operation or maintenance of the Products.

**CANCELLATION AND DEFAULT**

Absolutely no credit will be allowed for any change or cancellation of an order for Products by Buyer after fabrication of the Products to fill Buyer's order has been commenced. If Buyer shall default in paying for any Products purchased hereunder, Buyer shall be responsible for all reasonable costs and expenses, including (without limitation) attorney's fees incurred by the Seller in collecting any sums owed by Buyer. All rights and remedies to the Seller hereunder or under applicable laws are cumulative and none of them shall be exclusive of any other right to remedy. No failure by the Seller to enforce any right or remedy hereunder shall be deemed to be a waiver of such right or remedy, unless a waiver of law is signed by an authorized management employee of the Seller and the Seller's waiver of a breach of this agreement by Buyer shall not be deemed to be a waiver of any other breach of the same or any other provision.

**CHANGES IN PRODUCTS**

Changes may be made in materials, designs and specifications of the Products without notice. The Seller shall not incur any obligation to furnish or install any such changes or modifications on Products previously ordered by, or sold to, Buyer.

**APPLICABLE LAW, RESOLUTION OF DISPUTES AND SEVERABILITY**

This agreement is entered into in Costa Mesa, California. This agreement and performance by the parties hereunder shall be construed in accordance with, and governed by, the laws of the State of California. Any claim or dispute arising from or based upon this agreement or the Products which form its subject matter shall be resolved by binding arbitration before the American Arbitration Association in Los Angeles, California, pursuant to the Commercial Arbitration Rules, excepting only that each of the parties shall be entitled to take no more than two depositions, and serve no more than 30 interrogatories, 10 requests for admissions and 20 individual requests for production of documents, such discovery to be served pursuant to the California Code of Civil Procedure. Any award made by the arbitrator may be entered as a final judgment, in any court having jurisdiction to do so. If any provision of this agreement shall be held by a court of competent jurisdiction or an arbitrator to be unenforceable to any extent, that provision shall be enforced to the full extent permitted by law and the remaining provisions shall remain in full force and effect.

**ASSIGNMENT**

This agreement shall be binding upon the parties and their respective successors and assigns. However, except for rights expressly provided to subsequent Owners of the Products under "Limited Warranty" above,



Franklin Miller Inc.  
 60 Okner Parkway  
 Livingston, NJ 07039 USA  
 Tel 973-535-9200  
 Fax 973-535-6269  
 info@franklinmiller.com

**Quote No: 48212**

**May 27, 2020**

Page 1 of 3  
 ZZ950993

**City Of Duluth**  
 411 W 1St Street  
 Duluth, MN 55802 USA  
 Phone: 218-730-5083

**Your Local Representative:**  
 Northwestern Power Equipment Co.Inc  
 Attn: Doug Madole  
 Tel: 218-724-6096  
 email: dmadole@nwpeco.com

**Salesperson:**  
 Joseph Macula, Regional Sales Manager  
 jmacula@franklinmiller.com

We are pleased to quote on the following:  
 Project: Lift Station 15 Relocation

Quantity		Description	Price	Totals
1	EA	<b>Wet Well Frame CF4000 - 304SS</b> - Wall Mounted Support Structure - 304SS - Supports Grinder at influent to wet well - FRP Overflow Screen - Guide Rails with heavy duty supports  Note:Material made in USA.		
1	EA	<b>LIFTING CHAIN</b> - 316 Stainless Steel - Spreader Bar - Grab Link  Note: Material made in USA.		
1	EA	<b>US STEEL CERTIFICATION FOR WET WELL FRAME AND LIFTING CHAIN</b>		
<b>Total Lump Sum: \$20,748.00</b>				

Prices are Valid Until Friday, June 26, 2020  
 Terms: Net 30 days from shipment (subject of approval by Franklin Miller, Inc. Accounting Dept.).  
 Freight Allowed to Jobsite.

Delivery is 8 to 10 weeks after receipt of approval.

**Freight & Sales Tax (CA, NY, NJ) if applicable, will be added to Invoice.**

Thank you for this opportunity to be of service.

This quote is subject to Franklin Miller Standard Warranty, Terms and Conditions attached. Prices do not include applicable taxes.

..... See the difference



**FRANKLIN MILLER INC.**  
**TERMS AND CONDITIONS**  
**DATED 5/30/2019**

**1. ENTIRE AGREEMENT**

Any order resulting from a Franklin Miller ("SELLER") proposal shall be bound by the following Terms and Conditions. Any exception to these Terms and Conditions by the BUYER shall not be binding on SELLER unless agreed to in writing upon the parties hereto, their successors and assigns.

**2. LIMITED WARRANTY**

SELLER warrants the goods sold hereunder to be free from defects in material and workmanship under normal use and service not arising from misuse, negligence or accident, or unauthorized modification of the equipment, in connection with the use, installation, and transportation of the goods by BUYER, its agents, servants, employees or by carriers. SELLER's obligations under this warranty are limited to remedying any deficiencies in the goods at such place or places in the United States of America as may be designated by SELLER. This warranty shall pertain to any part or parts of any goods to which BUYER has, within (12) months after date of shipment given written notice of a claimed defect to the SELLER. The BUYER shall be required to furnish SELLER with details of such defects and this warranty shall be effective as to such goods which upon SELLER's examination shall disclose to its satisfaction to have been defective and which at SELLER's option shall be repaired in place if required for a warranty repair. The BUYER at his expense shall make available in a suitable location for repair by SELLER or promptly thereafter be returned to SELLER, at BUYER's, or its nominee's expense. If upon examination it is determined by the SELLER that the repair or replacement does not fall within the warranty as set forth in this clause, an estimate for cost of repair will be provided to the BUYER. This warranty is expressly in lieu of all other warranties expressed or implied. In no event shall the SELLER be liable to the BUYER or to any other person for any loss or damage, direct or indirect, arising out of or caused by the use or operation of the goods, or for the loss of profits, business, or good will. Under no circumstance will SELLER be liable for any of the following: (1) third party claims against BUYER for losses or damages including liquidated damages; (2) loss of or damage to BUYER's records or data; or (3) economic consequential damages (including loss of profits or savings) or incidental damages even if SELLER is informed of their possibility. Excluded from the warranty herein are (a) defects in parts or components not manufactured directly by SELLER (SELLER will, however, pass on the remaining balance of the purchased equipment manufacturer's warranty) or not part of SELLER's standard design or are supplied pursuant to special BUYER's requirements; (b) certain parts which are subject to wear and tear from abrasive action or use thereof; and (c) any part that has been subjected to misuse. SELLER's liability is limited to furnishing or repairing at SELLER's option parts determined by SELLER to be defective. **NO EXPRESS WARRANTIES AND NO IMPLIED WARRANTIES, WHETHER OF MERCHANTABILITY OR FITNESS FOR ANY PARTICULAR USE, OR OTHERWISE (EXCEPT AS TO TITLE) OTHER THAN THOSE EXPRESSLY SET FORTH ABOVE WHICH ARE MADE EXPRESSLY IN LIEU OF ALL OTHER WARRANTIES, SHALL APPLY TO PRODUCTS SOLD BY US.** In the case of delayed start-up, SELLER shall provide recommended maintenance and long-term storage instructions, including documentation forms which BUYER must complete in order to maintain this warranty. BUYER's failure to adhere to said maintenance instructions for any piece of the equipment shall void this warranty. Further, no waiver, alteration, or modification of the foregoing conditions shall be valid unless made in writing and signed by an executive officer of SELLER. If the BUYER is in default of Clause 6 (Payment of Purchase Price) this warranty is null and void unless reinstated by SELLER.

**3. FORCE MAJEURE**

The obligation of SELLER hereunder shall be modified or excused for reasons of act of God, war, changes in law or regulations, strikes or lock-outs, fire, breakdown of machinery, or if for any other cause beyond SELLER's control, including supplier delay, the goods cannot be delivered, or their delivery becomes delayed in whole or in part. In the above instances, time for delivery shall be extended for the period of the delay caused, with the proviso, however, that either party may cancel in writing the undelivered portion of the order or contract if the delay exceeds six (6) months from the delivery date originally confirmed by SELLER. In no event shall SELLER become liable in the aforesaid instances to BUYER or any third party for consequential damages, liquidated damages, particularly described in ARTICLE 2 herein.

**4. DELIVERY**

(a) All quoted delivery dates and/or periods are approximate. Unless otherwise agreed, delivery of the goods is F.O.B. Factory or (EX WORKS - INCOTERMS 2000). Delivery to any common carrier shall constitute delivery to BUYER, and thereafter the risk of loss or damage to the goods shall be upon BUYER. Delays by BUYER, Owner, or the engineer of the BUYER or Owner in furnishing necessary technical information or documents, or delays caused by order modifications requiring additional production time, shall result in a corresponding postponement of the delivery date.

**5. SHORTAGE OR DAMAGE OF DESTINATION SHIPMENTS**

Any claims of shortage or damage on destination shipments must be made in writing within ten (10) days after delivery of the goods (as to which such claim is made) to SELLER or its nominees, but in no event shall the claim be later than within the time limit provided by the carrier or insurance company, otherwise such claim shall be deemed waived.

**6. PAYMENT OF PURCHASE PRICE**

(a) Time of payment is of the essence under this contract. Upon default by BUYER in any of the terms of this contract, or failure to comply with any of the conditions hereof, or upon seizure of the property under execution or other legal process, or if BUYER becomes bankrupt or insolvent, or any petition for reorganization or for a state court receivership is filed against BUYER, or if the BUYER makes any assignment for the benefit of his creditors or otherwise sells, encumbers or disposes of the merchandise, or if for any other reason the SELLER should deem itself insecure, the full amount of the purchase price then remaining unpaid shall at once become due and payable at the option of the SELLER. Then, at its option, SELLER may take possession of any goods theretofore sold to BUYER, in connection with which the full purchase price has not been paid, analogous to the terms and provisions set forth herein.

(b) **TERMS OF PAYMENT** - All orders are subject to credit approval by the SELLER. Payment terms are as stated in SELLER's quotation. Retainage if required by OWNER shall be no more than 5% of the purchase price. Retainage shall be released and paid in full no later than 120 days after satisfactory start up of the SELLER's equipment. All shipments, including partial shipments, will be billed a pro rata amount as of date shipped. If the account remains unpaid after sixty (60) days, interest at the rate of 1-1/2% per month (18% per annum) will be added to the outstanding balance computed from date of shipment. All costs of collection will be added to the outstanding balance including legal fees and court costs. Acceptance of partial payments on account does not constitute any change in the payment terms and conditions herein and is not to be considered to extend the due date for payment.

**7. SECURITY INTEREST AND TITLE**

In states and localities which are governed by the Uniform Commercial Code, this contract shall serve as the security agreement, reserving in SELLER a security interest until full payment of purchase price. The provisions of the Uniform Commercial Code regarding security interest shall have preference and apply if inconsistent with other terms of the conditions of sale herein. In states and localities where the Uniform Commercial Code does not apply, title to the merchandise shall remain in the SELLER or its assigns until full payment of the purchase price. BUYER agrees to execute forthwith any and all documents in such form as SELLER may require for filing or recording the security interest under the Uniform Commercial Code with the proper registers or offices, or for filing or recording the conditional sales contract.

**8. VARIATIONS IN DUTIES AND TAXES & RATE OF EXCHANGE**

The prices on the products specified are exclusive of all city, state or federal taxes. BUYER shall bear any increases, after the date of this contract, in or any new imposition of duties, levies or taxes relating to the product sold hereunder. Unless a Sales Tax Exemption Certificate is provided, SELLER will invoice for the New Jersey Sales Tax on all items sold in New Jersey. SELLER is not authorized to collect sales tax for any other jurisdiction.

**9. MODIFICATIONS AND CANCELLATION**

The parties may agree to modify project plans or specifications provided BUYER pays SELLER for engineering time, materials costs, and other expenses relating to the requested modification. An order, once placed with and accepted by SELLER can be canceled only with SELLER's consent and upon terms that will indemnify SELLER against loss.

**FRANKLIN MILLER INC.**  
**TERMS AND CONDITIONS**  
**DATED 5/30/2019**

**10. STOP WORK ORDER OR DELAY:**

If an engineering approval, release to manufacturer, shipment or work on any part of this contract is held or delayed by BUYER for greater than 120 days from the date of contract, SELLER is entitled to an increase in contract price to cover cost escalations caused by such delay.

**11. MISCELLANEOUS PROVISIONS**

(a) If for any reason a provision of the contract is legally invalid, then in such event the rest of the contract shall remain in full force and effect; (b) Any amendment to any contract or contracts shall require the consent in writing of both parties; and (c) The within terms shall govern in any instance where they conflict with the provisions of any forms used by BUYER.

**12. BUYER'S RESPONSIBILITY AS TO MAINTENANCE**

BUYER shall use and shall require its employees and agents to use all safety devices and guard safe operating procedures and shall maintain the same in proper working order. Further, BUYER shall obey and have its employees, subcontractors and agents obey safety instructions given by SELLER. BUYER agrees to indemnify and save SELLER harmless from any liability or obligation with respect to any personal injuries or property damage directly or indirectly connected with the operation of the equipment. BUYER agrees to notify SELLER promptly and in any event not less than ten (10) days after notice or knowledge of any accident or malfunction involving SELLER's equipment which has caused personal injury or property damages and to cooperate fully with SELLER in investigating and determining the causes of such accident.

**13. REPAIR OBLIGATION FOR CONTAMINATED EQUIPMENT**

Nothing herein shall be deemed to require SELLER to accept equipment for repair, modification or alteration unless the units have first been cleaned and decontaminated.

**14. NOISE LEVEL REQUIREMENTS**

Although SELLER's machines have been designed to satisfy the general requirements of BUYER's specifications, SELLER cannot represent or certify that they satisfy the noise level requirements for a specific application, location or operation since these circumstances are unknown to SELLER and are beyond SELLER's control and because of the general nature of size reduction equipment. If required to test for this noise level requirement, testing will be with no product fed to the machine and FMI will provide a quotation for each test to be performed. If corrections are required after completion of the tests, the costs for these modifications will be negotiated.

**15. OSHA CONDITIONS**

Although SELLER's machines and guards have been designed to satisfy the general intentions of OSHA requirements, SELLER cannot present or certify that they satisfy the requirements of OSHA for a specific application, location, or operation since these circumstances are unknown to SELLER and are beyond SELLER's control. The SELLER shall not be liable for any costs of compliance or other costs or fines resulting from non-compliance with any OSHA requirement.

**16. DOCUMENTS REQUIRED**

Prices quoted include the required number of manuals set forth in the specifications. If not stated, SELLER shall provide its standard Operations and Maintenance Manuals. Any additional manuals are not included in the quoted price and shall be charged to BUYER.

**17. PATENT AND LICENSE & LIABILITY INDEMNIFICATION**

BUYER agrees to indemnify SELLER, its agents, successors and assigns against any loss, damage and liability, including costs and expenses arising out of any claim against SELLER for actual or alleged infringement on any patent, copyright or trademark arising out of the use or sale by BUYER, its agents, servants, employees or customers of the product provided by SELLER, as used by BUYER, in conjunction with any other equipment, product or system. BUYER agrees to indemnify SELLER, its agents, successors and assigns against any loss, damage and liability, including costs and expenses arising out of any claim against SELLER for actual or "Bodily injury" or "property damage" arising from the actual, alleged or threatened discharge, dispersal, release or escape of pollutants from any source whatsoever. "Pollutants" means any solid, liquid, gaseous or thermal irritant or

contaminant, including smoke, vapor, soot, fumes, acids, alkalis, chemicals and waste. Waste includes materials to be recycled, reconditioned or reclaimed.

**18. TRADEMARKS AND COPYRIGHTS**

BUYER acknowledges that it has no right, title or interest in the trademarks or copyrights in the products, and BUYER covenants that it will take no action to register or otherwise interfere with such rights.

**19. INDEPENDENT CONTRACTORS**

SELLER and BUYER are independent contractors. BUYER is not authorized to and shall not make any representations on behalf of which are binding upon SELLER.

**20. NON-ASSIGNMENT BY BUYER**

Contract or contracts may not be assigned by the BUYER without prior written consent of the SELLER.

**21. APPLICABLE LAW**

Any contracts herein are governed by the applicable laws of the State of New Jersey.

**22. BUYER APPROVALS**

If BUYER approval is required of the SELLER's submittals, specifications and/or operating instructions submissions, upon receipt of such approval, the approved documents shall supersede the BUYER's description of requirements on this purchase order and the description on the SELLER's original proposal. SELLER will provide equipment, spares and data in accordance with the approved submittals.

**23. STANDARD PRODUCTS**

All of SELLER's machines are built to best commercial practices and as part of its standard product line, which may be modified to meet BUYER's specifications. However, no manufacturing drawings or procedures, formal inspection plans, schedules, progress reports, welding procedures, quality control plans, or sub-supplier information, will be supplied. Erection, safety, operation and maintenance instructions are contained in SELLER's manual to be supplied with the machines.

**24. SIZES AND DIMENSIONS**

The samples, measurements, dimensions and weights contained in the SELLER's catalogs, sales manuals, photographs and drawings constitute only an approximate guide. The SELLER reserves the right to make any changes which the SELLER, in its absolute discretion, considers necessary.

**25. ARBITRATION**

Actions by the SELLER for nonpayment by the BUYER of the undisputed purchase price of goods sold by the SELLER, or for redress for other undisputed breaches by the purchaser of the contract of sale, may be brought by the SELLER before any judicial court of competent jurisdiction without need for prior arbitration. All other disputes, controversies, or claims arising out of or relating to this agreement or the performance or breach thereof shall be settled by arbitration by an arbitrator mutually agreeable to be held in the County of Essex, State of New Jersey in accordance with the rules and procedure then obtaining of the American Arbitration Association.

**26. FORUM.**

**ALL JUDICIAL PROCEEDING AND/OR ARBITRATION BROUGHT AGAINST BORROWER ARISING OUT OF OR RELATING TO THIS NOTE MAY BE BROUGHT IN ANY STATE OR FEDERAL COURT OF COMPETENT JURISDICTION IN THE STATE OF NEW JERSEY, AND BY EXECUTION AND DELIVERY OF THIS AGREEMENT BUYER ACCEPTS FOR ITSELF AND IN CONNECTION WITH ITS PROPERTIES, GENERALLY AND UNCONDITIONALLY, THE JURISDICTION OF THE AFORESAID COURTS AND FORUM FOR ARBITRATION AND WAIVES ANY DEFENSE OF FORUM NON CONVENIENS AND IRREVOCABLY AGREES TO BE BOUND BY ANY JUDGMENT RENDERED THEREBY IN CONNECTION WITH THIS AGREEMENT.** BUYER hereby agrees that service of process sufficient for personal jurisdiction in any action against BUYER in the State of New Jersey may be made by registered or certified mail, return receipt requested, to BUYER at its address as provided by BUYER. BUYER hereby acknowledges that such service shall be effective and binding in every respect.

{This page left blank}