



Staff Report for PLCUP-2602-0002

Application Information:

Application Type: Concurrent Use Permit for Wireless Facility/Micro Site

Location of Subject: Near 2827 Parkwood Lane

Legal Description: 010-3754-00450

Applicant: AT&T

Applicant Contact: n/a

Agent: Teri Clark

Agent Contact: Smartlink LLC

Staff Contact: Chris Lee, clee@duluthmn.gov

Deadline for Action:

Application Date: February 26, 2026

Date Extension Letter Mailed: March 6, 2026

60 Days: April 27, 2026

120 Days: June 26, 2026

Site Visit Date: March 27, 2026

Sign Notice Date: March 31, 2026

Neighbor Letter Date: Not Applicable

Number of Letters Sent: 0

Proposal:

Applicant is seeking concurrent use permit to install a new wireless microsite to a new pole in the right of way for Parkwood Lane.

Recommended Action:

Staff recommends Planning Commission recommend approval.

Zoning and Land Use:

	Current Zoning	Existing Land Use	Future Land Use Map Designation
Subject	R-1	Single Family Residential	Low-density Neighborhood
North	R-1	Single Family Residential	Low-density Neighborhood
South	R-1	Single Family Residential	Low-density Neighborhood
East	R-1	Single Family Residential	Low-density Neighborhood
West	R-1	Single Family Residential	Low-density Neighborhood

Summary of Code Requirements:

50-20.4.E. Major utility or wireless telecommunications facility.

UDC Section 50-37.7.C. Concurrent Use Permits: The planning commission shall review the application, and council shall approve the application or approve it with modifications, if it determines that the proposed concurrent use will not harm or inconvenience the health, safety and general welfare of the city, and no portion of a public easement proposed of use is being physically occupied by the public.

Comprehensive Plan Governing Principle and/or Policies and Current History (if applicable):

Future Land Use: Low-density neighborhood: Single-family housing with urban services. Typified by curvilinear streets, houses with longer dimension parallel to street, and attached garages. Includes a range of house sizes and lot sizes. Non-residential uses are mainly uses such as schools and churches.

History: Not Applicable.

Review and Discussion Items:

Staff finds:

- 1) The small cell facility will be installed on a replacement Minnesota Power wooden pole in the same location as the existing one. The existing light will be reinstalled at 26 feet to a new pole increasing in height by 3 feet to 29 feet tall. and wireless equipment will be placed at 29 to 33 feet, with a radio at 20 feet. Wireless attachments will include 1 exterior mounted panel antenna and 1 radio unit. There will be no ground mounted equipment. The new pole will have a structural analysis by the manufacturer to ensure that they can support the weight of the private small cell facilities.
- 2) Granting a concurrent use permit would give the applicant the ability to use a portion of the right of way, with conditions, while preserving other existing public uses. Unlike street vacations, concurrent use permits are not recorded at the County as they are voidable permits issued by the City to applicants who are private users of public rights of way.
- 3) Ownership of the pole will remain with Minnesota Power. Liability, maintenance, and operation of the small wireless facilities will remain the responsibility of the applicant. In the event of an accident, such as a vehicle hitting the utility pole, the city is not responsible for restoring or replacing any of the applicant's equipment.
- 4) Granting the proposed concurrent use permits will not harm or inconvenience the health, safety and general welfare of the city. It will not cause any additional obstructions within the right of way, and the applicant will be required to maintain liability insurance over their facilities, with the City of Duluth named an additional insured on the policy.
- 5) The UDC generally requires that new wireless facilities follow a location standard: they should be collocated on existing towers or other structures on city owned properties first, and then existing towers or other structures on other (private) property, and so forth down the location standard list. Per Minnesota Statutes Section 237.163 the City processes these small cell facilities as concurrent use permits for occupying the right-of-way and, to the extent prohibited by state statute, the use specific standards do not apply.
- 6) The city has the ability to regulate land use; however, the Federal Communications Commission preempts local review on the potential environmental effects of radio frequency (RF) emissions, with the presumption that the applicant and service provider is in compliance with the Commission's RF rules. The applicant included an FCC checklist used to determine exemption from RF regulations (unlikely to cause exposure in excess of the FCC's guidelines). The installation falls with the provisions of Minnesota Statute 237.162 and 247.1643, as amended in 2017.
- 7) The ordinance will require that the project proposer will locate any underground items in accordance with Gopher State One Call rules, and that the city will bear no responsibility for locating any facility related to the concurrent use permit except as it is legally responsible under the Gopher State One Call rules.
- 8) One public comment was received in opposition. No other public, agency, or Citizen comments have been received.

Staff Recommendation:

Based on the above findings, Staff recommends that Planning Commission recommend approval of the concurrent use permit with the following conditions:

- 1) The project be limited to, constructed, and maintained according to construction drawings submitted and included with this staff report along with any revisions as requested by City Engineering.
- 2) Applicant provide annual proof of liability insurance and agree to indemnify the City against any occurrences in the right of way that are due to items covered under this permit.
- 3) Applicant, and/or successors, shall remove the proposed obstructions at applicant's expense if directed to do so by the City with appropriate notice, and shall adhere to other standards and obligations established in the approving document (ordinance).
- 4) Any alterations to the approved plans that do not alter major elements of the plan may be approved by the Land Use Supervisor without further Planning Commission approval; however, all other changes must be approved by amending the City Council's approved ordinance.

Staff Report Map for PLCUP-2602-0002:

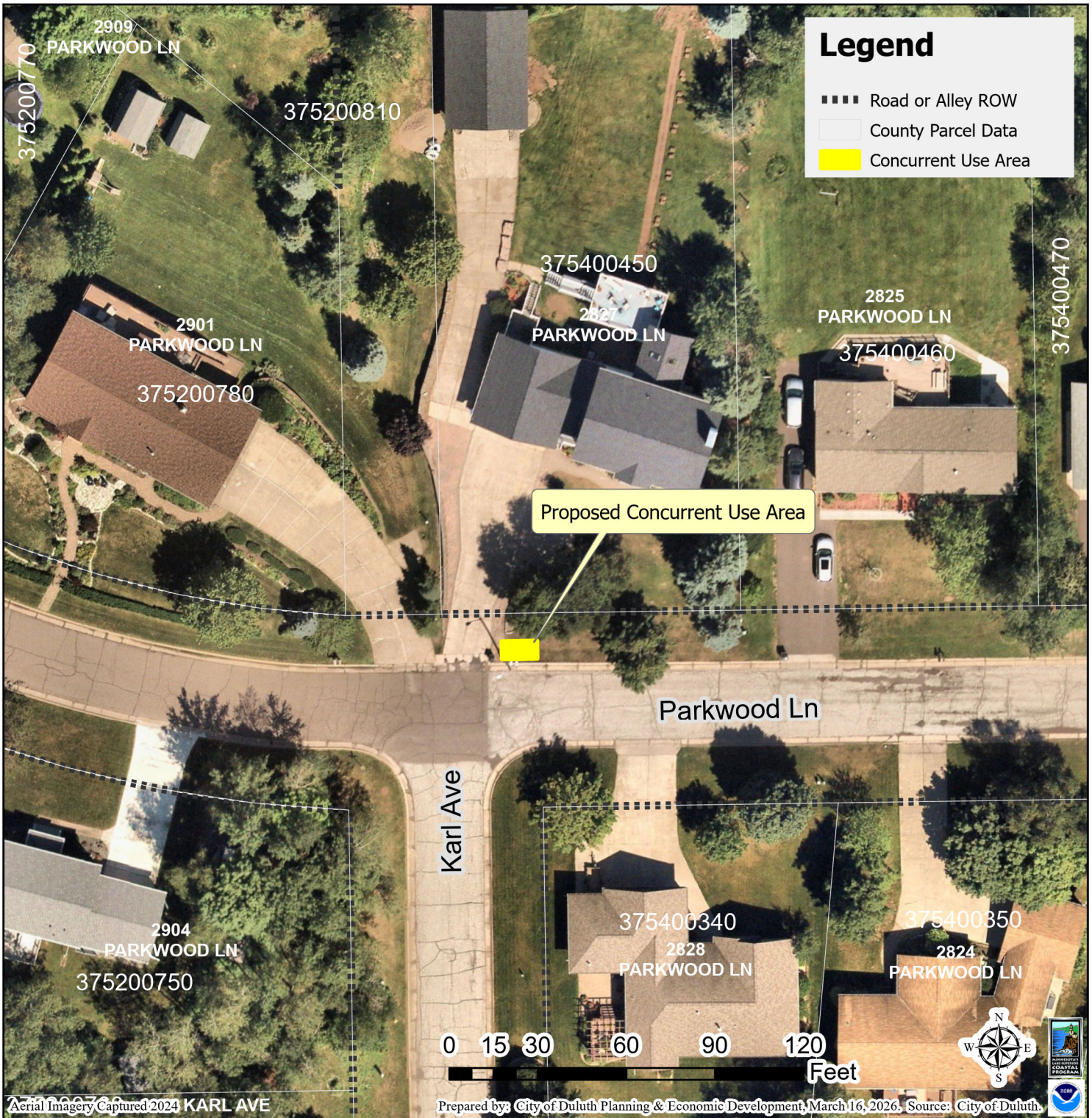

Figure 1.

Aerial imagery captured in 2024, showing a proposed Concurrent Use area near 2904 Parkwood Ln, along the boulevard of Parkwood Ln, located within the right-of-way northeast of 2828 Parkwood Ln.

The City of Duluth has tried to ensure that the information contained in this map or electronic document is accurate. The City of Duluth makes no warranty or guarantee concerning the accuracy or reliability. This drawing/data is neither a legally recorded map nor a survey and is not intended to be used as one. The drawing/data is a compilation of records, information and data located in various City, County and State offices and other sources affecting the area shown and is to be used for reference purposes only. The City of Duluth shall not be liable for errors contained within this data provided or for any damages in connection with the use of this information contained within.

Disclaimer for Externally Sourced Application Files

We strive to ensure digital accessibility for all users and comply with the Americans with Disabilities Act (ADA) and Web Content Accessibility Guidelines (WCAG) standards. The following documents are provided in the original format in which they were submitted. If you require an accessible version or alternative format, please contact us at info@duluthmn.gov.

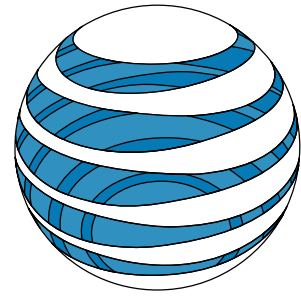

at&t
mobility corp.



SITE ID: SIMN002672
SITE NAME: CRAN_RUMW_GECHL_012
FA LOCATION: 14828511
USID: 227133
ADDRESS: 2904 PARKWOOD LANE
CITY: DULUTH
STATE: MINNESOTA
STRUCTURE TYPE: WOOD POLE
STRUCTURE OWNER: MINNESOTA POWER



7900 XERXES AVE. S., 3RD FLR
BLOOMINGTON, MN 55431

ENGINEER SEAL:

I HEREBY CERTIFY THAT THIS PLAN, SPECIFICATION, OR REPORT WAS PREPARED BY ME OR UNDER MY DIRECT SUPERVISION AND THAT I AM A DULY LICENSED PROFESSIONAL ENGINEER UNDER THE LAWS OF THE STATE OF MINNESOTA.

SIGNATURE: _____

TYPED OR PRINTED NAME: _____

L.I.S. NO. _____

DATE: _____

PRELIMINARY - NOT FOR CONSTRUCTION

TITLE SHEET
CRAN_RUMW_GECHL_012
DULUTH, MINNESOTA

JOB DETAIL

IWM JOB NUMBER	ORACLE PTN	JOB SCOPE
WSUMW0051712 WSUMW0060079	3514A1HNMA 3514AA5LCD	LTE1C - PICO CELL 1SR 5G NR CBAND MICRO NODE

SHEET INDEX

NO.:	SHEET TITLE
G-001	TITLE SHEET
G-002	GENERAL SPECIFICATIONS
-	SITE SURVEY *
C-101	SITE PLAN
T-201	SITE ELEVATION
T-501	EQUIPMENT SPECIFICATIONS
T-502	INSTALLATION DETAILS
P-501	PLUMBING DIAGRAM *
E-501	UTILITY DETAILS
E-502	UTILITY DETAILS
E-503	GROUNDING DETAILS
R-001	COMPLIANCE LETTER *
R-002	COMPLIANCE LETTER *
R-003	COMPLIANCE LETTER *
R-501	SIGN DETAILS

* PROVIDED BY OTHERS

CONTRACTOR SHALL VERIFY ALL PLANS AND EXISTING DIMENSIONS/CONDITIONS ON SITE. IMMEDIATELY NOTIFY ENGINEER OF ANY DISCREPANCIES PRIOR TO PERFORMING ANY WORK OR BE RESPONSIBLE FOR THE SAME.

SITE LOCATION MAP

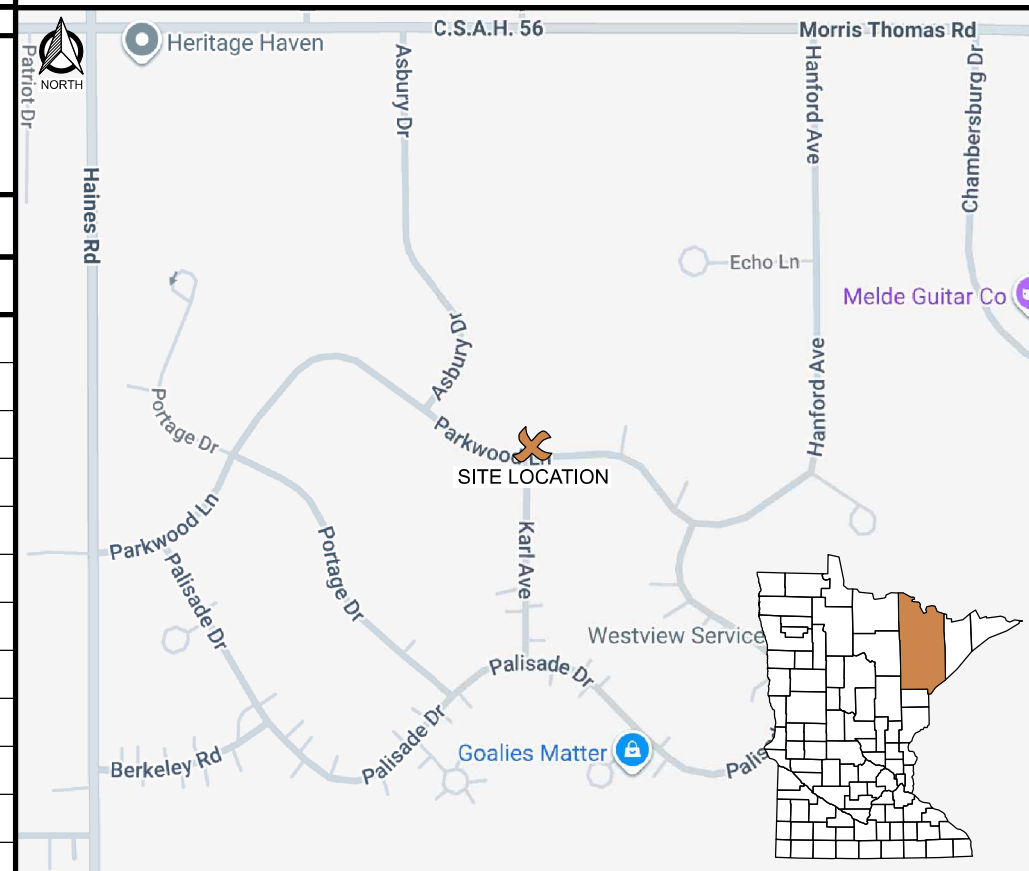

DIRECTORY

APPLICANT:
AT&T MOBILITY
7900 XERXES AVE. S
3rd FLOOR
BLOOMINGTON, MN 55431
PM: CARL KAHLSTORF
EMAIL: ck168e@att.com
CM: PETER MCENERY
EMAIL: pm753t@att.com

PROJECT MANAGER:
SMARTLINK
10 CHURCH CIRCLE
ANNAPOLIS, MD 21401
CONTACT: JACKEE SPOHR
EMAIL: jacquelyn.spohr@smartlinkgroup.com
PHONE: 248.798.1419

ENGINEERING COMPANY:
EDGE CONSULTING ENGINEERS, INC.
624 WATER STREET
PRAIRIE DU SAC, WI 53578
CONTACT: MIKE MLINER
EMAIL: mmliner@edgeconsult.com
PHONE: 608.644.1449

CONSTRUCTION MANAGEMENT:
MASTEC SOLUTIONS
CONTACT: DYLAN DAVIS
EMAIL: dylan.davis@mastec.com
PHONE: 318.505.3307

PROJECT INFO

APPROX. ADDRESS:
2904 PARKWOOD LANE
DULUTH, MN 55811
ST. LOUIS COUNTY

SITE COORDINATES:
LATITUDE: 46° 46' 29.33 N (46.774814°)
LONGITUDE: 92° 10' 08.22" W (-92.168950°)
GROUND ELEVATION: 1315'

HUB ID:
TBD

SITE ID:
SIMN002672

FA LOCATION:
14828511

USID:
227133

STRUCTURE OWNER:
MINNESOTA POWER
30 W SUPERIOR STREET
DULUTH, MN 55802
CONTACT: JUSTIN REINEKE
EMAIL: Justin.Reineke@ISGInc.com
PHONE: 920.434.2128
POLE ID: M5409469

JURISDICTION:
CITY OF DULUTH

SCOPE OF WORK

- REMOVE (1) WOOD POLE (BY OTHERS)
- INSTALL (1) WOOD POLE (BY OTHERS)
- INSTALL (1) ELECTRIC METER (BY OTHERS)
- INSTALL (1) GALTRONICS GC2414-07320-112 ANTENNA - AZIMUTH 200°
- INSTALL (1) CONCEALFAB 007951
- INSTALL (1) CONCEALFAB 900192 MOUNT
- INSTALL (1) ERICSSON 4461 B77D RRH
- INSTALL (1) ERICSSON 4471 B86 RRH
- INSTALL (1) ERICSSON 6308 PSU
- INSTALL (1) PACIFIC TECHNICAL SOLUTIONS PTS-90126-6E-XXX-P2N DISCONNECT
- INSTALL (1) ERICSSON SEF 901 376/0642
- INSTALL (3) ERICSSON SEF 901 377/2 EQUIPMENT MOUNTS
- INSTALL NEW FIBER, DC POWER, AND COAX CABLES

SITE LOCATION



TO OBTAIN LOCATION OF PARTICIPANTS' UNDERGROUND FACILITIES BEFORE YOU DIG IN MINNESOTA, CALL GOPHER STATE ONE CALL

TOLL FREE: 1-800-252-1166
FAX A LOCATE: 1-800-236-4967

MN STATUTE REQUIRES MIN. OF 48 HOURS NOTICE BEFORE YOU EXCAVATE

SUBMITTAL:

INT.	DATE:	DESCRIPTION:
TJT	12/16/25	REV A
MJM	02/26/26	REV B

CHECKED BY: MJM

EDGE SITE ID: S18113

EDGE PROJ. #: 44861

SET TYPE: PRELIM

SHEET NUMBER: **G-001**

I:\4800\44861\Drawings\CADD\PHI\PHI(G-001).dgn

GENERAL CONSTRUCTION NOTES:

1. THE EXISTING TOPOGRAPHY AND VERTICAL GEOMETRY REPRESENTED ON THESE DRAWINGS IS TO BE VERIFIED BY CONTRACTOR. CONTRACTOR SHALL CONTACT UTILITY LOCATE SERVICES A MINIMUM OF 72 HOURS PRIOR TO THE START OF CONSTRUCTION TO IDENTIFY THE EXISTENCE AND LOCATION OF UNDERGROUND AND OVERHEAD UTILITIES AND SERVICES. CONTRACTOR IS TO IMMEDIATELY NOTIFY ENGINEER OF DISCREPANCIES OR INTERFERENCE THAT WILL EFFECT THIS PROJECT. EXISTING UTILITIES SHALL BE PROTECTED AND REPAIRED O THE CONTRACTORS EXPENSE IF DAMAGED. EXTREME CAUTION SHOULD BE USED BY THE CONTRACTOR WHEN EXCAVATING OR PIER DRIVING AROUND OR NEAR UTILITIES. CONTRACTOR SHALL PROVIDE SAFETY TRAINING FOR THE WORKING CREW.
2. DAMAGE TO THE EXISTING FACILITY SHALL BE REPAIRED OR REPLACED TO MATCH EXISTING ORIGINAL CONDITIONS AT THE CONTRACTOR'S EXPENSE.
3. EXISTING INACTIVE UTILITIES, WHICH PROHIBIT CONSTRUCTION, SHALL BE REMOVED, CAPPED, PLUGGED OR OTHERWISE DISCONTINUED AS REQUIRED TO ALLOW CONSTRUCTION TO CONTINUE, COORDINATE WITH PROJECT MANAGER, OWNER, AND /OR LOCAL UTILITY COMPANIES FOR APPROVAL.
4. CONTRACTOR SHALL NOTIFY THE PROPERTY OWNER OF THE CONSTRUCTION START WELL IN ADVANCE (MIN. 1 WEEK) OF THE CONSTRUCTION DATE.
5. PROVIDE LABOR, MATERIAL, TOOL..S, EQUIPMENT, TRANSPORTATION AND TEMPORARY POWER SERVICES NECESSARY FOR, AND INCIDENTAL TO COMPLETION OF WORK AS INDICATED ON THE DRAWINGS AND/OR AS SPECIFIED HEREIN.
6. THE CONTRACTOR SHALL FURNISH AND INSTALL MATERIALS AS REQUIRED FOR COMPLETE SYSTEMS, INCLUDING PARTS OBVIOUSLY OR REASONABLY INCIDENTAL TO A COMPLETE INSTALLATION, WHETHER SPECIFICALLY INDICATED OR NOT. SYSTEMS SHALL BE COMPLETELY ASSEMBLED, TESTED, ADJUSTED AND DEMONSTRATED TO BE READY FOR OPERATION PRIOR TO OWNER'S ACCEPTANCE.
7. THE CONTRACTOR SHALL OBTAIN, PAY FOR AND DELIVER REQUIRED PERMITS, CERTIFICATES OF INSPECTION, INCLUDING UTILITY CONNECTION FEES, ETC. REQUIRED BY THE AUTHORITIES HAVING JURISDICTION. DELIVER CERTIFICATES TO THE OWNER PRIOR TO FINAL ACCEPTANCE OF THE WORK.
8. THE CONTRACTOR SHALL MAINTAIN BENCHMARKS, CONSTRUCTION STAKING, AND OTHER ELEVATION CONTROL POINTS AND SHALL REESTABLISH, IF DISTURBED OR DESTROYED, AT NO ADDITIONAL COST TO THE OWNER.
9. THE CONTRACTOR SHALL BE RESPONSIBLE FOR REPAIR AND OR RESTORATION OF DAMAGE TO THE EXISTING ACCESS ROADWAY AND ADJACENT SITE AREAS AS A RESULT OF USE DURING CONSTRUCTION AS FURTHER SPEAFIED IN THE RESTORATION 110N NOTES BELOW UPON COMPLETION OF WORK AT THE EXPENSE OF THE CONTRACTOR.
10. THE CONTRACTOR SHALL REMOVE WASTE, DEBRIS AND TRASH FROM SITE AND DISPOSE OF IN A LEGAL MANNER ON A DAILY BASIS.
11. CONTRACTOR SHALL COORDINATE THE CONSTRUCTION STAGING AREA AND PARKING WITH THE PROPERTY OWNER PRIOR TO THE CONSTRUCTION START DATE.
12. THE CONTRACTOR SHALL NOT INTERFERE w/ THE NORMAL OPERATIONS. ACCESS TO THE WORK AREA SHALL BE AS DIRECTED BY THE FACILITY'S OWNER.
13. THE CONTRACTOR SHALL CONFINE THEIR OPERATIONS TO THE DESIGNATED AREAS AND SHALL KEEP THE CONSTRUCTION AREA CLEAN. AISLES AND PATHWAYS SHALL BE KEPT UNOBSTRUCTED.
14. THE CONTRACTOR SHALL COORDINATE THE WORK OF VARIOUS TRADES SO AS TO INSURE PROPER SEQUENCING AND INSTALLATION.
15. WORK PERFORMED UNDER THIS CONTRACT SHALL BE DONE IN STRICT ADHERENCE TO ALL LOCAL, STATE AND FEDERAL CODES AND BEST PRACTICES. THIS SHALL INCLUDE SAFETY, ENVIRONMENTAL, TRAFFIC, CONSTRUCTION, RESTORATION, AND OTHER CODES AND STATUTES THAT GOVERN SPECIFIC ACTIVITIES.
16. TRAFFIC CONTROL ON ALL COUNTY AND STATE HIGHWAY RIGHT-OF-WAY SHALL MEET THE REQUIREMENTS OF THE MANUAL OF UNIFORM TRAFFIC CONTROL DEVICES (U.S. DOT/FHA) AND REQUIREMENT OF THE STATE AND ANY OTHER LOCAL AGENCY HAVING JURISDICTION.
17. POLYETHYLENE PIPE WILL BE IN ACCORDANCE WITH AWWA STANDARD C 906 FOR POLYETHYLENE PRESSURE PIPE AND FITTINGS. POLYETHYLENE PIPE SHALL BE SDR 11 PE-3408 WITH O.D. EQUAL TO DUCTILE IRON PIPE.

ELECTRICAL NOTES:

1. WORK UNDER THIS CONTRACT SHALL BE DONE IN STRICT ACCORDANCE WITH ALL APPLICABLE MUNICIPAL, STATE, AND LOCAL ELECTRICAL CODES THAT GOVERN EACH PARTICULAR TRADE AND THE NATIONAL ELECTRICAL CODE (LATEST EDITION).
2. THE CONTRACTOR SHALL EXAMINE DRAWINGS AND SHALL INSPECT THE EXISTING CONDITIONS OF THE SITE. FAILURE TO COMPLY WITH THIS REQUIREMENT WILL NOT RELIEVE THE CONTRACTOR OF RESPONSIBILITY FOR COMPLYING WITH THE CONTRACT DOCUMENTS.
3. THE DRAWINGS INDICATE THE GENERAL ARRANGEMENT OF THE ELECTRICAL INSTALLATIONS. DETAILS OF PROPOSED DEPARTURES DUE TO ACTUAL FIELD CONDITIONS OR OTHER CAUSES SHALL BE SUBMITTED FOR APPROVAL PRIOR TO INSTALLATION. REWORK OF COMPLETED ITEMS DUE TO IMPROPER FIELD COORDINATION SHALL BE AT THE CONTRACTOR'S EXPENSE.
4. PROVIDE SUFFICIENT ACCESS AND CLEARANCE FOR ITEMS OR EQUIPMENT REQUIRING SERVICING AND MAINTENANCE.
5. THE CONTRACTOR SHALL PREPARE THREE (3) COPIES OF A RECORD AND INFORMATION BOOKLET. THE BOOKLET SHALL BE BOUND IN A THREE RING LOOSE-LEAF BINDER AND INCLUDE ALL ITEMS OF ELECTRICAL EQUIPMENT.
6. UPON COMPLETION OF THE ELECTRICAL INSTALLATION, THE CONTRACTOR SHALL PROVIDE A COMPLETE SET OF PRINTS OF THE ELECTRICAL CONTRACT DRAWINGS WHICH SHALL BE LEGIBLY MARKED IN RED TO SHOW ALL CHANGES AND DEPARTURES OF THE INSTALLATIONS COMPARED WITH THE ORIGINAL DESIGN. THEY SHALL BE SUITABLE FOR USE IN PREPARATION OF RECORD DRAWINGS.
7. GUARANTEE: NEW ELECTRICAL INSTALLATIONS SHALL BE GUARANTEED FOR A PERIOD OF ONE (1) YEAR BEGINNING THE DAY OF THE FINAL ACCEPTANCE OF THE WORK OR BENEFICIAL OCCUPANCY OF THE OWNER, WHICHEVER OCCURS FIRST. THE ABOVE SHALL NOT IN ANY WAY VOID OR ABROGATE EQUIPMENT MANUFACTURER'S GUARANTEE OR WARRANTY. CERTIFICATES OF GUARANTEE SHALL BE DELIVERED TO THE OWNER, UPON RECEIPT OF NOTICE FROM THE OWNER OF FAILURE OF ANY PART OF THE ELECTRICAL INSTALLATION DURING THE GUARANTEE PERIOD. NEW REPLACEMENT PARTS SHALL BE FURNISHED AND INSTALLED PROMPTLY AND AT NO COST TO OWNER.
8. ELECTRICAL WORK WHICH WILL INTERFERE WITH THE NORMAL USE OF THE ELECTRICAL SYSTEM IN ANY MANNER SHALL BE DONE AT SUCH TIME OR TIMES AS SHALL BE MUTUALLY AGREED UPON BETWEEN THE CONTRACTOR AND THE U.S. CELLULAR CONSTRUCTION MANAGER.
9. MOUNTING AND SUPPORTING OF EQUIPMENT PROVIDED BY THIS CONTRACTOR SHALL BE COORDINATED WITH U.S. CELLULAR CONSTRUCTION MANAGER IN THE FIELD.

CONDUIT AND BOXES NOTES:

1. CONDUIT BELOW GRADE SHALL BE SCHEDULED 40 PVC UNLESS NOTED OTHERWISE.
2. BOXES (WHETHER OUTLET, JUNCTION, PULL, OR EQUIPMENT) SHALL BE FURNISHED WITH APPROPRIATE COVERS.
3. NO SECTIONALIZED BOXES SHALL BE USED.
4. EMT CONDUIT FITTINGS SHALL BE COMPRESSION TYPE.
5. FIELD CUTS OR GALVANIZED ITEMS SHALL BE BRUSHED WITH MARINE GRADE GALVANIZING.
6. METALLIC OBJECTS EXPOSED TO WEATHER SHALL BE HOT DIPPED GALVANIZED OR STAINLESS STEEL.

RESTORATION NOTES:
(CONSTRUCTION IN RIGHT-OF-WAYS)

1. ANY OPEN ROAD CUT REQUIRES PRIOR APPROVAL OF THE CITY, COUNTY, STATE OR ANY OTHER AGENCY WHICH MAY HAVE JURISDICTION.
2. ALL CONSTRUCTION, MATERIALS AND WORKMANSHIP SHALL BE IN ACCORDANCE WITH THE LOCAL JURISDICTION REQUIREMENTS, SPECIFICATIONS AND STANDARDS.
3. THE CONTRACTOR SHALL INSTALL APPROVED EROSION CONTROL MEASURES AND COMPLY WITH ALL RULES AND REGULATIONS OF THE STATE, COUNTY OR CITY AUTHORITIES REGARDING CLOSING OR RESTRICTING THE USE OF PUBLIC STREETS OR HIGHWAYS. STREETS MUST BE OPENED TO TRAFFIC BY THE END OF THE BUSINESS DAY DURING CONSTRUCTION.
4. CONTRACTOR SHALL INSTALL BLACK DIRT AND PREMIUM TOP SOIL PRIOR TO SEEDING AND FERTILIZING REPAIRED AREAS IF SOD IS NOT INSTALLED. ALSO INSTALL STRAW MAT OR A COCOA MAT OVER THE BLACK DIRT TO PREVENT SURFACE EROSION.
5. CONTRACTOR SHALL MINIMIZE DRIVING ON THE RIGHT-OF-WAY AND UTILIZE LANE CLOSURES WHENEVER POSSIBLE TO MINIMIZE DAMAGE AND NEED FOR RESTORATION.
6. CONTRACTOR SHALL SET VAULT TOPS TO BE LEVEL WITH FINISHED GRADE AND NOT INTERFERE WITH MOWING OPERATIONS OR CREATE TRIPPING HAZARDS.
7. AFTER COMPLETION OF THE NODE INSTALLATION ALL AREA IN EXISTING RIGHT-OF-WAY DISTURBED BY CONSTRUCTION SHALL BE RESTORED EQUAL TO OR BETTER THAN ORIGINAL CONDITION, WHICH MAY INCLUDE THE INSTALLATION OF SOD, AND BE TO THE SATISFACTION OF THE PERMITTING AGENCY WITHIN A 7-DAY PERIOD OR LESS IF DICTATED BY THE LOCAL JURISDICTION.
8. STREET OR HIGHWAY RESTORATION SHALL BE DONE AS PER LOCAL OR STATE AGENCY HAVING JURISDICTION.
9. THE CONTRACTOR SHALL COMPLY WITH ALL RULES AND REGULATIONS OF THE STATE, COUNTY OR CITY AUTHORITIES REGARDING CLOSING OR RESTRICTING THE USE OF PUBLIC STREETS OR HIGHWAYS. STREETS MUST BE OPENED TO TRAFFIC BY THE END OF THE BUSINESS DAY.



ENGINEER SEAL:

I HEREBY CERTIFY THAT THIS PLAN, SPECIFICATION, OR REPORT WAS PREPARED BY ME OR UNDER MY DIRECT SUPERVISION AND THAT I AM A DULY LICENSED PROFESSIONAL ENGINEER UNDER THE LAWS OF THE STATE OF MINNESOTA.

SIGNATURE: _____

TYPED OR PRINTED NAME: _____

L.I.S. NO. _____

DATE: _____

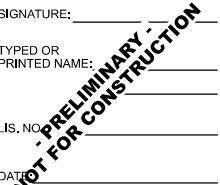

GENERAL SPECIFICATIONS
CRAN RUMW GECHL 012
DULUTH, MINNESOTA

SUBMITTAL:

INT.	DATE:	DESCRIPTION:
TJT	12/16/25	REV A
MJM	02/26/26	REV B

CHECKED BY: MJM

EDGE SITE ID: S18113

EDGE PROJ. #: 44861

SET TYPE: PRELIM

SHEET NUMBER: **G-002**

**SITE LOCATION SURVEY FOR:
EDGE CONSULTING ENGINEERS, INC.**

SITE LOCATION: Parkwood Lane and Karl Avenue, Duluth, Minnesota

SITE NAME: CRAN RUMW GECHL 012

SECOND ADDITION TO PARKWOOD

BLOCK 6

LOT 1

SOUTHEAST CORNER OF LOT 1, BLOCK 6, SECOND ADDITION TO PARKWOOD

S'LY LINE OF LOT 1, BLOCK 6, SECOND ADDITION TO PARKWOOD

RIGHT OF WAY LINE
S89°33'26"W 82.21

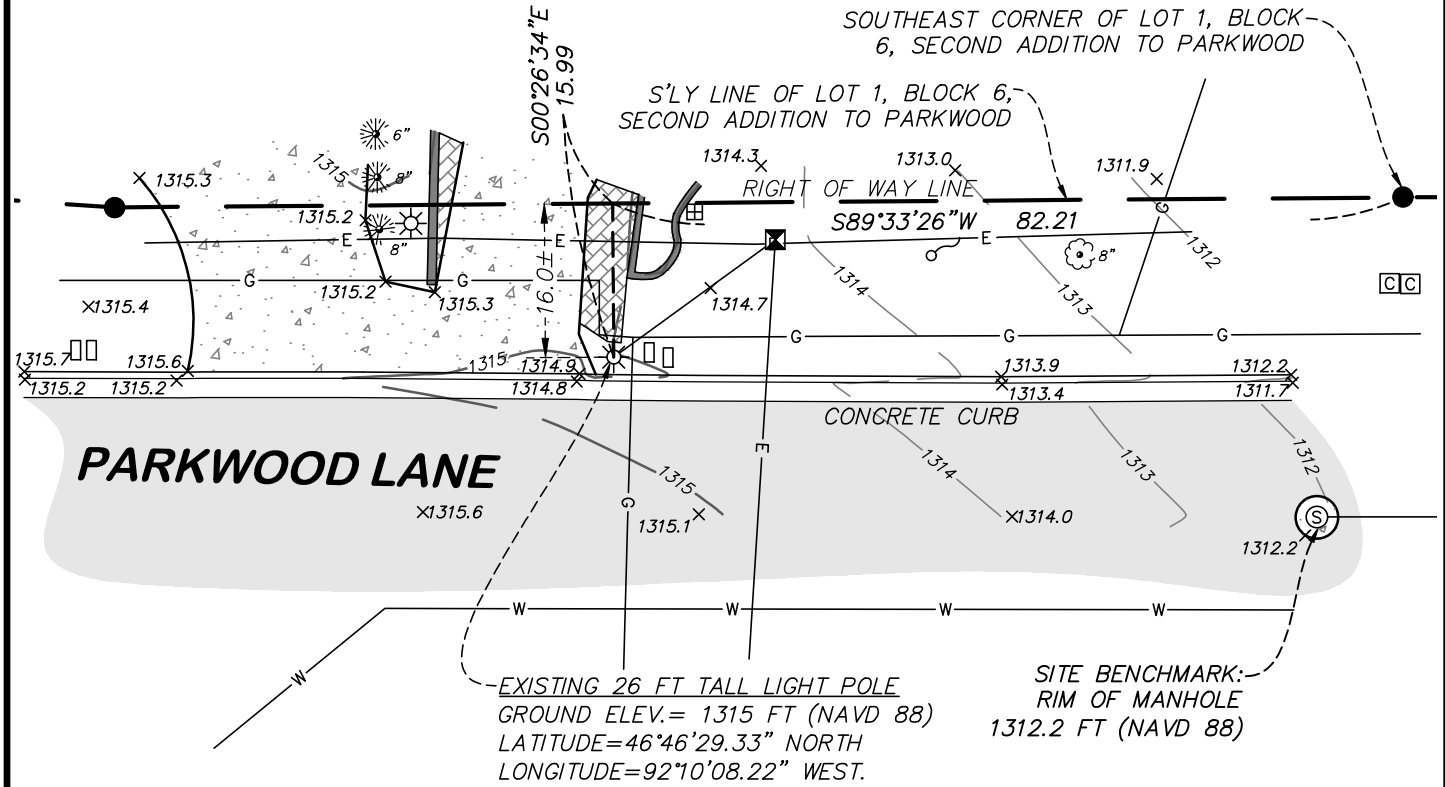

NOTES:

- The orientation of this survey is based on the St. Louis County (South), Minnesota Coordinate Grid, NAD 83-2011 Adjustment.
- The contours depicted hereon are per elevation data collected while conducting the fieldwork using Vertical Datum of 1988 (NAVD 88). The contour interval is 1 foot.
- Existing utilities, services and underground structures shown hereon were located either physically, from existing records made available to us, by resident testimony, or by locations provided by Gopher State One Call, per Ticket No. 253112028. However, lacking excavation, the exact location of underground features cannot be accurately, completely and reliably depicted. Where additional or more detailed information is required, the client is advised that excavation may be necessary. Other utilities and services may be present and verification and location of all utilities and services should be obtained from the owners of the respective utilities prior to any design, planning or excavation.

DESCRIPTION

A point located within that part of Parkwood Lane as dedicated on the SECOND ADDITION TO PARKWOOD, St. Louis County, Minnesota described as follows:

Commencing at the southeast corner of Lot 1, Block 6, SECOND ADDITION TO PARKWOOD; thence South 89 degrees 33 minutes 26 seconds West, assumed bearing, along the southerly line of said Lot 1, a distance of 82.21; thence South 00 degrees 26 minutes 34 seconds East, a distance of 15.99 feet to said point.

Dated this 25th day of February, 2026

**SITE LOCATION SURVEY FOR:
EDGE CONSULTING ENGINEERS, INC.**
SITE LOCATION: Parkwood Lane
and Karl Avenue, Duluth, Minnesota



Egan, Field & Nowak, Inc.
land surveyors since 1872

475 Old Highway 8 NW, Suite 200
New Brighton, Minnesota 55112
PHONE: (612) 466-3300
WWW.EFNSURVEY.COM

COPYRIGHT © 2025 By EGAN, FIELD & NOWAK, INC.

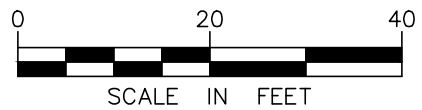
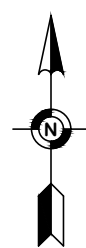

LEGEND

- FOUND IRON MONUMENT
- ⊙ SANITARY MANHOLE
- ⊠ ELECTRIC BOX
- ⊞ ELECTRIC METER
- ☀ LIGHT
- ⊕ FLAGPOLE
- MAILBOX
- ⊕ POWER POLE WITH LIGHT
- ⊞ COMMUNICATION BOX
- S— SANITARY SEWER
- W— WATERMAIN
- E— UNDERGROUND ELECTRIC
- G— UNDERGROUND GAS
- x 920.1 SPOT ELEVATION
- 920 EXISTING CONTOUR LINE
- ☀ OR ☀ TREE
- ▒ BITUMINOUS SURFACE
- ▒ CONCRETE SURFACE
- ▒ PAVER SURFACE
- ▒ RETAINING WALL

GENERAL NOTES: (THIS SHEET)

1. ALL HARDWARE SHALL BE STAINLESS STEEL.
2. ALL CABLES SHALL BE SECURED TO POLE EVERY 36" OR LESS.
3. LIGHTNING RODS SHALL BE INCLUDED WHERE REQUIRED.
4. ALL HEIGHTS ARE LISTED ABOVE GRADE LEVEL (A.G.L.).

ENGINEER SEAL:
I HEREBY CERTIFY THAT THIS PLAN, SPECIFICATION, OR REPORT WAS PREPARED BY ME OR UNDER MY DIRECT SUPERVISION AND THAT I AM A DULY LICENSED PROFESSIONAL ENGINEER UNDER THE LAWS OF THE STATE OF MINNESOTA.

SIGNATURE: _____
TYPED OR PRINTED NAME: _____
LIS. NO. _____
DATE: _____

PRELIMINARY - NOT FOR CONSTRUCTION

**SITE ELEVATION
CRAN RUMW GECHL 012
DULUTH, MINNESOTA**

SUBMITTAL:

INT.	DATE:	DESCRIPTION:
TJT	12/16/25	REV A
MJM	02/26/26	REV B

CHECKED BY	MJM
EDGE SITE ID	S18113
EDGE PROJ. #	44861
SET TYPE	PRELIM
SHEET NUMBER	T-201

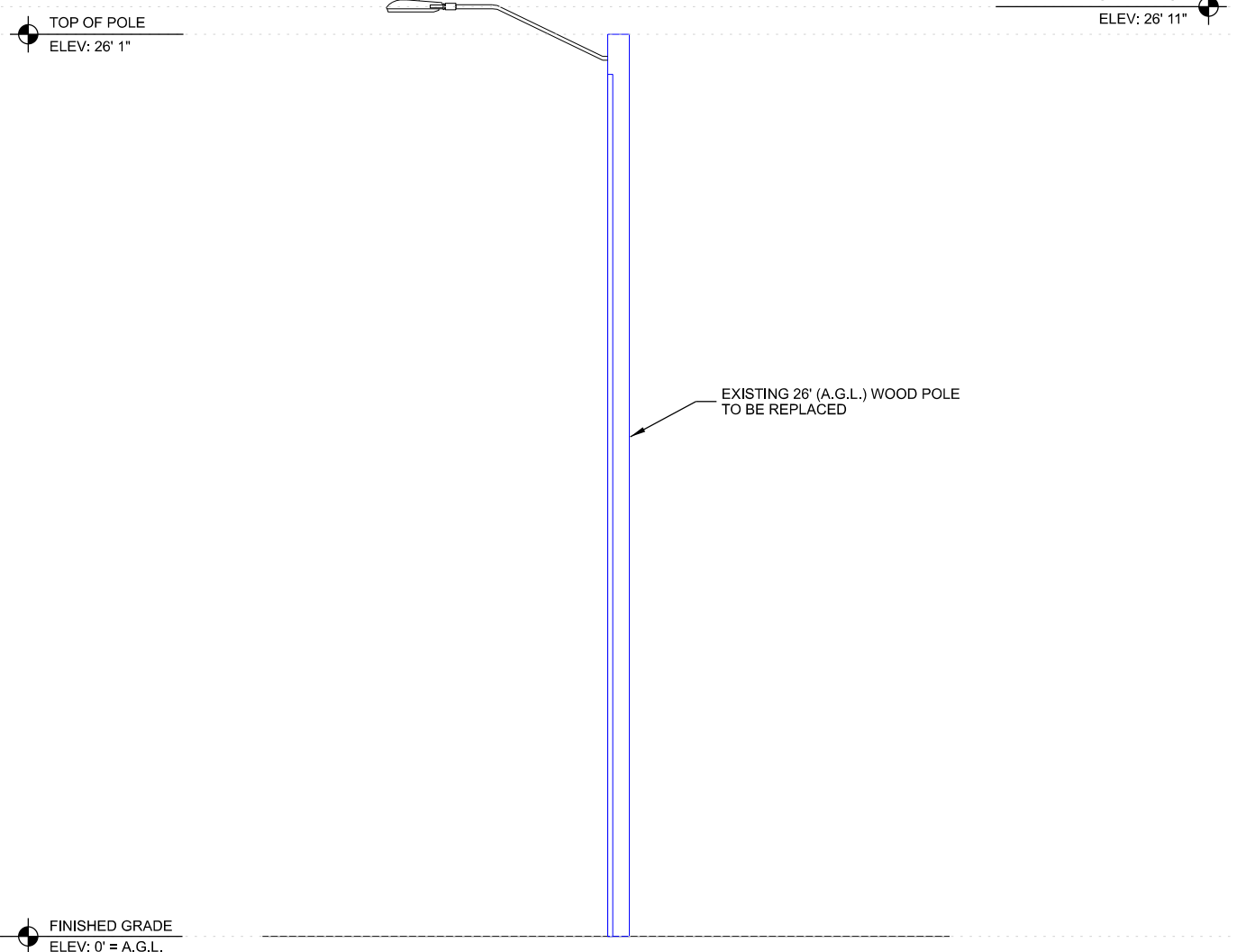

A EXISTING ELEVATION

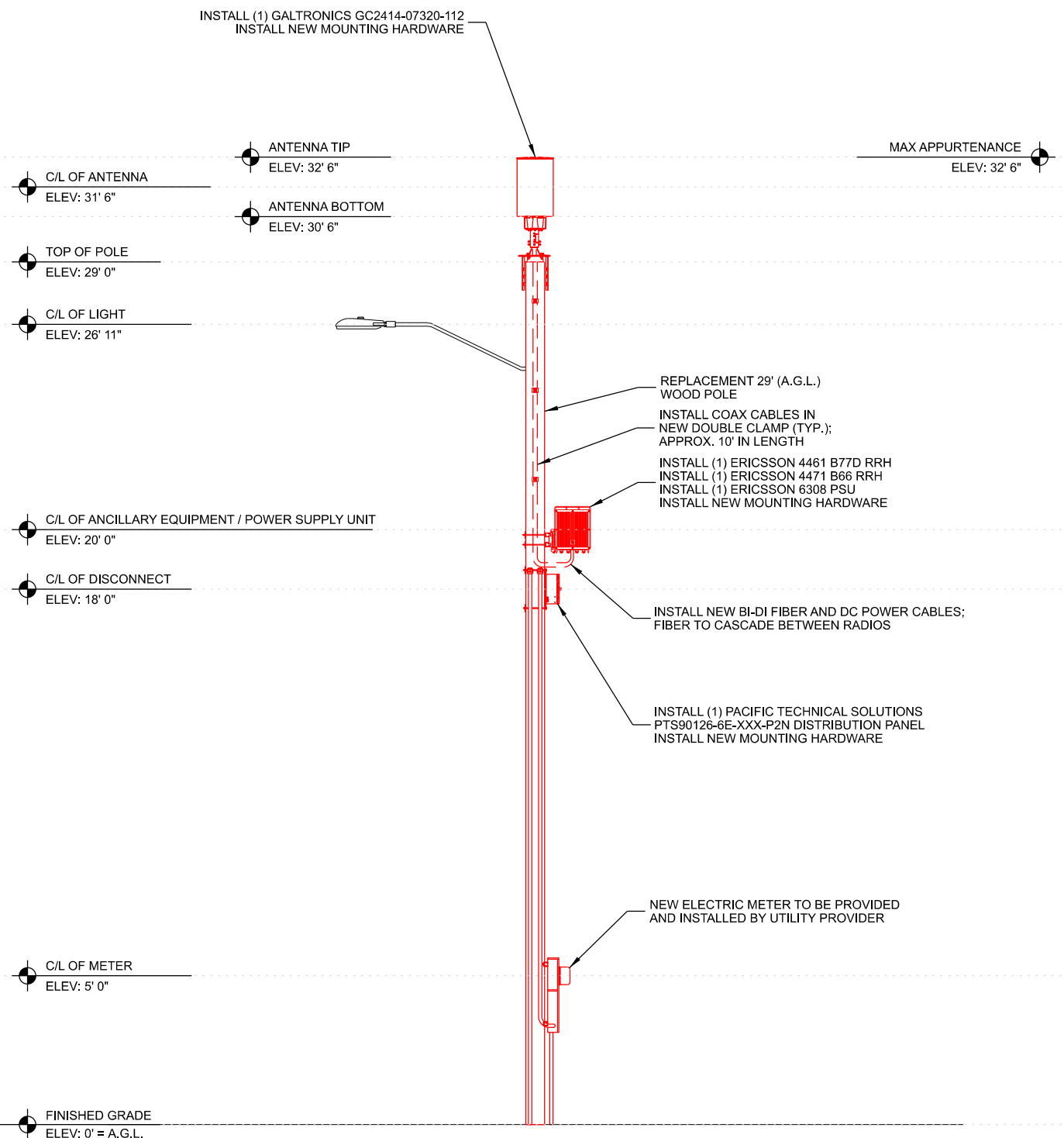

B PROPOSED ELEVATION

MANUFACTURER: GALTRONICS
 MODEL: GC2412-07320
 DIMENSIONS: 24.0" x 14.5" (H x DIA.)
 WEIGHT: 20 LBS.

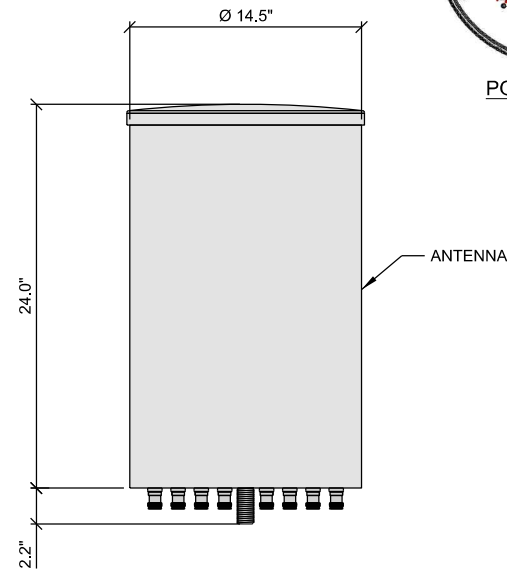
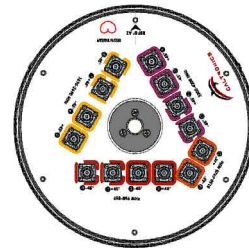

A GALTRONICS GC2414-07320
 ANT.53303

MANUFACTURER: ERICSSON
 MODEL: RADIO 4461 B77D
 DIMENSIONS: 13.9" x 10.3" x 4.4" (H x W x D)
 WEIGHT: 24.3 LBS

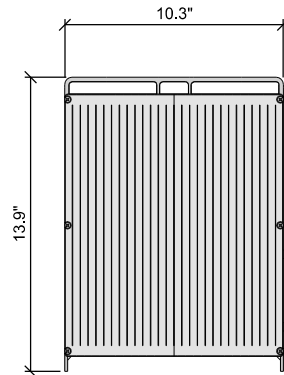
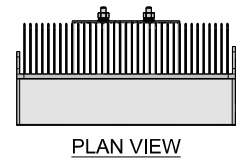

B ERICSSON RADIO 4461
 CEQ.TBD

MANUFACTURER: ERICSSON
 MODEL: RADIO 4471
 DIMENSIONS: 16.1" x 10.6" x 5.6" (H x W x D)
 WEIGHT: 28.4 LBS

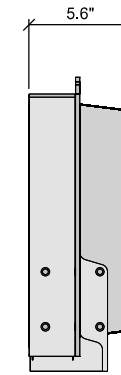
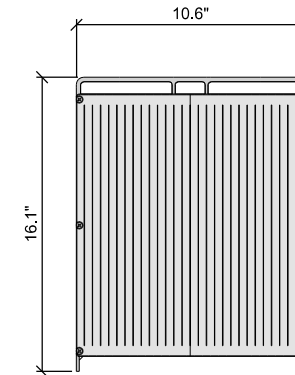
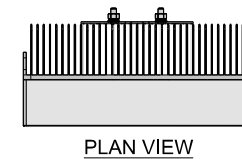

C ERICSSON RADIO 4471
 CEQ.TBD

MANUFACTURER: ERICSSON
 MODEL: PSU 6308
 DIMENSIONS: 18.8" x 13.5" x 4.33" (H x W x D)
 WEIGHT: 30.86 LBS.

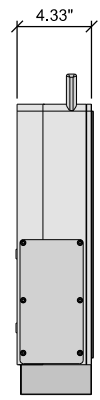
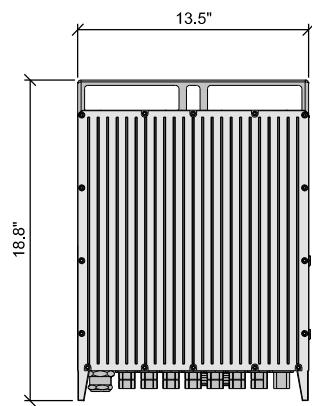
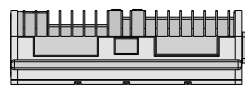

D ERICSSON PSU 6308 (POWER SUPPLY UNIT)
 CEQ.57704

MANUFACTURER: PACIFIC TECHNICAL SOLUTIONS
 MODEL: PTS-90126-6E-XXX-P2N
 DIMENSIONS: 11.88" x 6.70" x 5.33" (H x W x D)
 WEIGHT: 9 LBS.
 208/240 VAC, 8 POSITION POWER DISTRIBUTION PANEL WITH SURGE PROTECTION
 FACTORY LOADED 60AMP MAIN BREAKER WITH 50AMP 2P POLE MOUNTING BRACKET INCLUDED

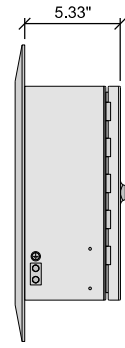
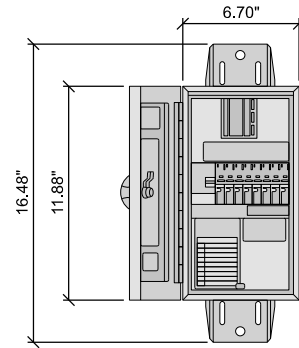
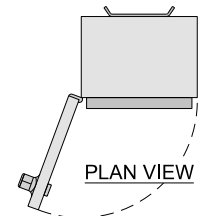

E DISTRIBUTION PANEL / SURGE PROTECTION
 NEQ.59085

THIS SPACE INTENTIONALLY LEFT BLANK



ENGINEER SEAL:
 I HEREBY CERTIFY THAT THIS PLAN, SPECIFICATION, OR REPORT WAS PREPARED BY ME OR UNDER MY DIRECT SUPERVISION AND THAT I AM A DULY LICENSED PROFESSIONAL ENGINEER UNDER THE LAWS OF THE STATE OF MINNESOTA.

SIGNATURE: _____
 TYPED OR PRINTED NAME: _____
 LIS. NO. _____
 DATE: _____

PRELIMINARY NOT FOR CONSTRUCTION

EQUIPMENT SPECIFICATIONS
 CRAN_RUMW_GECHL_012
 DULUTH, MINNESOTA

SUBMITTAL:		
INT.	DATE:	DESCRIPTION:
TJT	12/16/25	REV A
MJM	02/26/26	REV B

CHECKED BY	MJM
EDGE SITE ID	S18113
EDGE PROJ. #	44861
SET TYPE	PRELIM
SHEET NUMBER	T-501

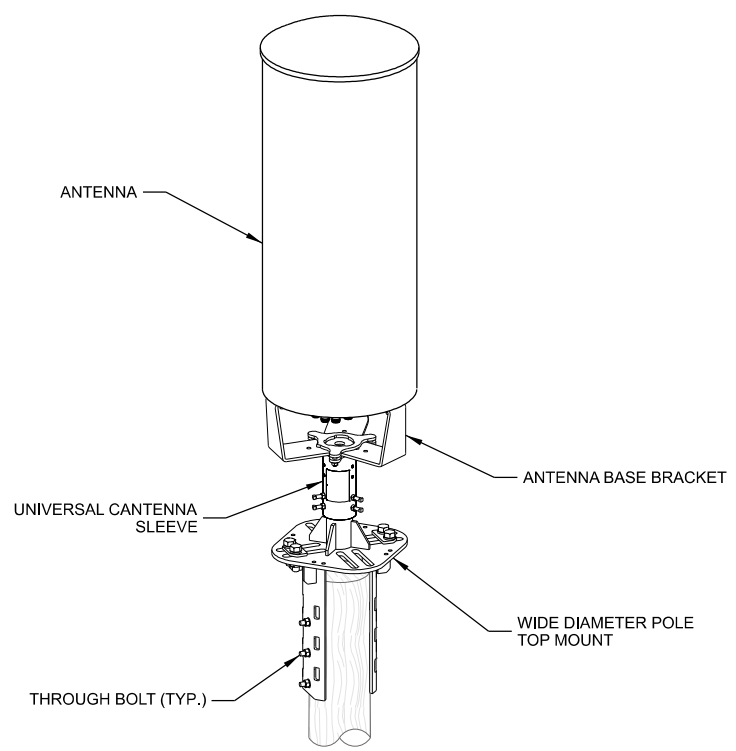

A ANTENNA INSTALLATION

MANUFACTURER: CONCEALFAB
MODEL: 007951-#
DESCRIPTION: WIDE DIAMETER POLE TOP MOUNT
DIMENSIONS: 19 3/4" x 12 3/4" (H x W)
 FITS POLES 5 1/4" DIA. TO 14 1/8" DIA.

MANUFACTURER: CONCEALFAB
MODEL: 900192-#
DESCRIPTION: UNIVERSAL ANTENNA SLEEVE
DIMENSIONS: 6 5/8" x 6 3/16" x 5 13/16" (H x W x D)
 FITS 2" (2 5/8" O.D.) MOUNTING POST

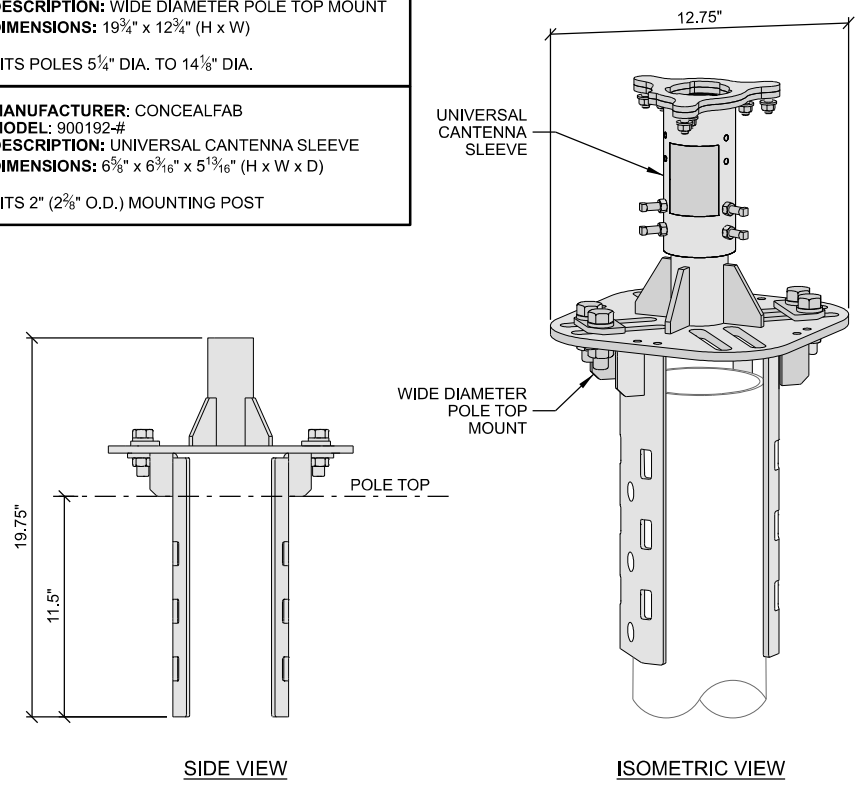

B WIDE DIAMETER POLE TOP MOUNT
 ANT.45703 & ANT.45705

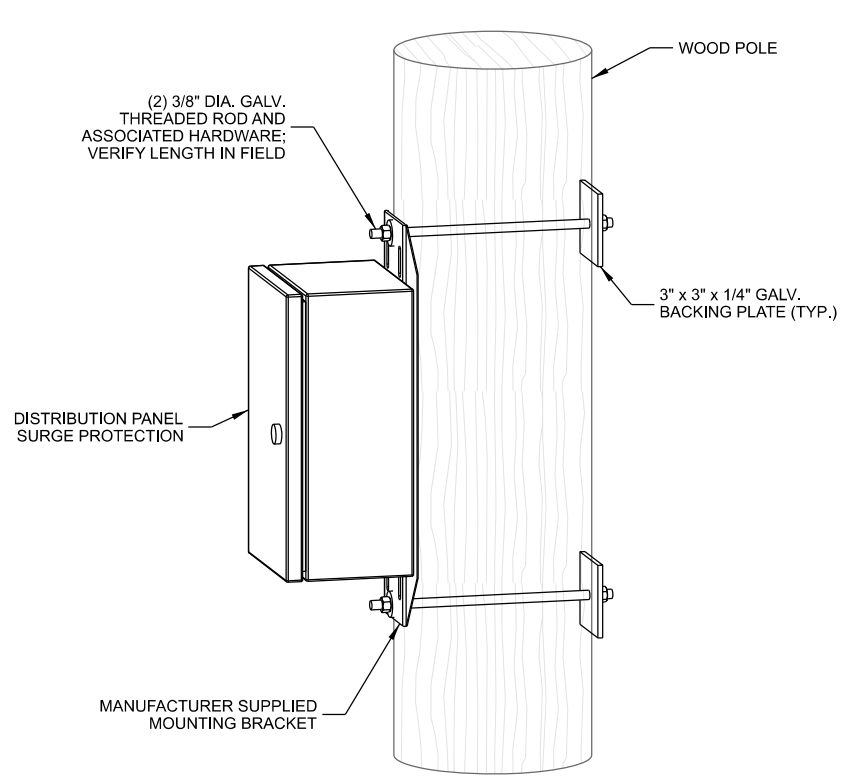

C DISTRIBUTION PANEL / SURGE PROTECTION MOUNT

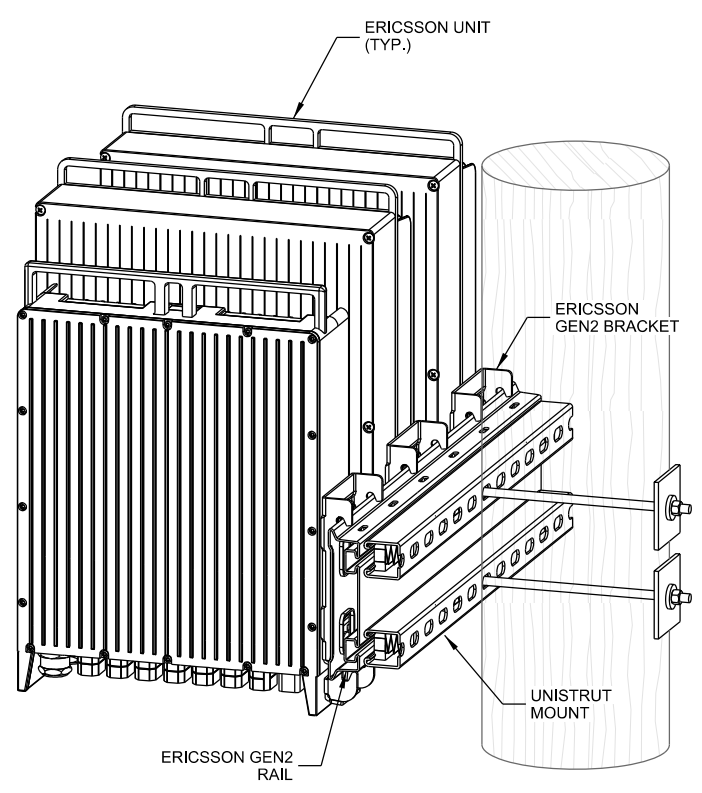

D ERICSSON UNIT

MANUFACTURER: ERICSSON
MODEL: SEF 901 376/0642
DESCRIPTION: GEN2 RAIL - 642mm LENGTH

MANUFACTURER: ERICSSON
MODEL: SEF 901 377/2
DESCRIPTION: GEN2 MEDIUM BRACKET

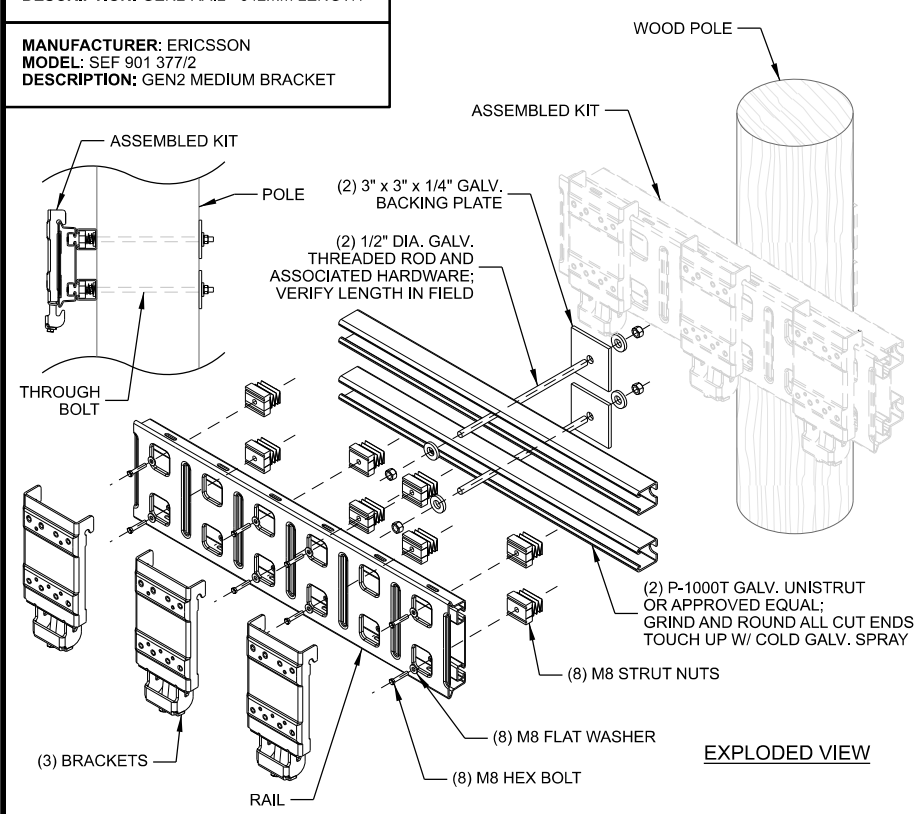

E ERICSSON GEN2 RAIL/BACKET ASSEMBLY
 (1) CEQ.57214 & (3) CEQ.57212

MANUFACTURER: ROSENBERGER
MODEL: TH494-DC12
 DOUBLE CLAMP TO SUIT 1/2" COAX CABLE SOLD IN KITS OF (10)

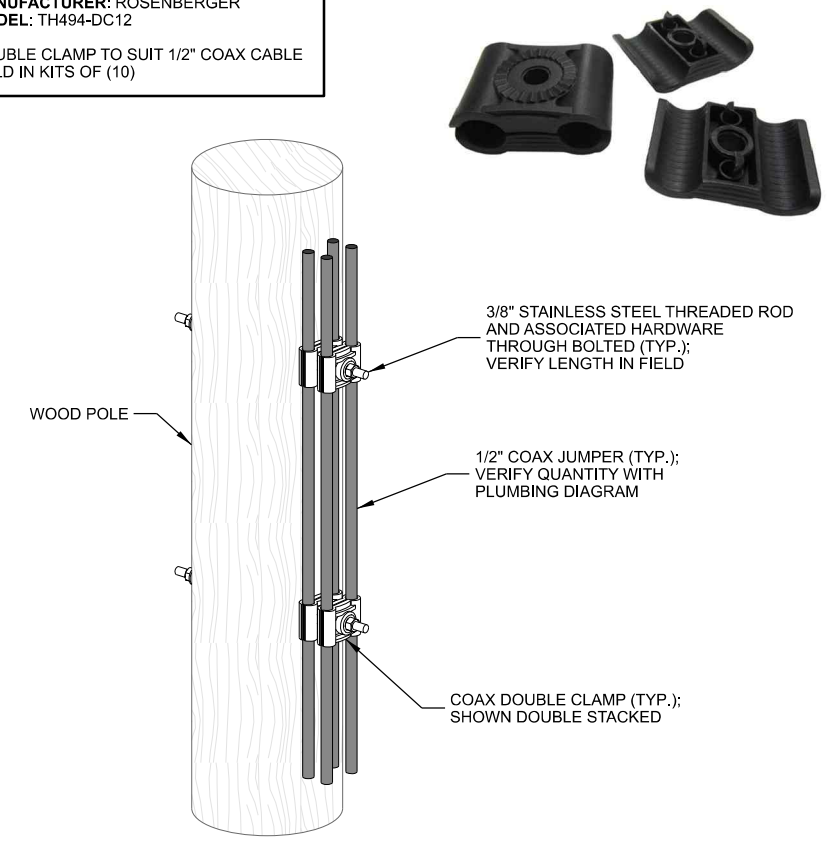

F COAX DOUBLE CLAMP
 ANT.13858



ENGINEER SEAL:
 I HEREBY CERTIFY THAT THIS PLAN, SPECIFICATION, OR REPORT WAS PREPARED BY ME OR UNDER MY DIRECT SUPERVISION AND THAT I AM A DULY LICENSED PROFESSIONAL ENGINEER UNDER THE LAWS OF THE STATE OF MINNESOTA.
 SIGNATURE: _____
 TYPED OR PRINTED NAME: _____
 LIS. NO. _____
 DATE: _____

PRELIMINARY - NOT FOR CONSTRUCTION

INSTALLATION DETAILS
CRAN RUMW GECHL 012
DULUTH, MINNESOTA

SUBMITTAL:

INT.	DATE:	DESCRIPTION:
TJT	12/16/25	REV A
MJM	02/26/26	REV B

CHECKED BY:	MJM
EDGE SITE ID:	S18113
EDGE PROJ. #:	44861
SET TYPE:	PRELIM
SHEET NUMBER:	T-502

Sector A

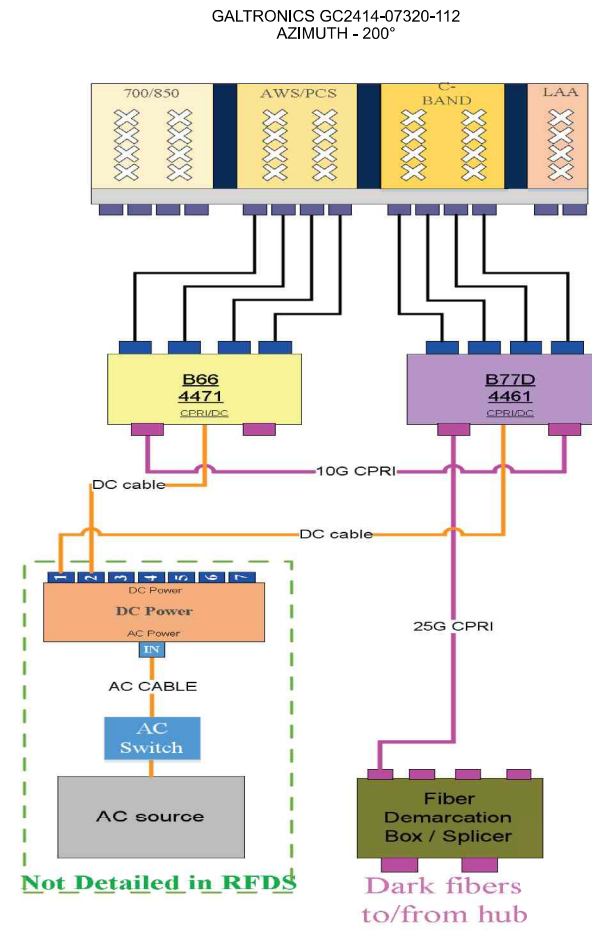

ENGINEER SEAL:
I HEREBY CERTIFY THAT THIS PLAN, SPECIFICATION, OR REPORT WAS PREPARED BY ME OR UNDER MY DIRECT SUPERVISION AND THAT I AM A DULY LICENSED PROFESSIONAL ENGINEER UNDER THE LAWS OF THE STATE OF MINNESOTA.

SIGNATURE: _____
TYPED OR PRINTED NAME: _____
LIS. NO. _____
DATE: _____

PRELIMINARY - NOT FOR CONSTRUCTION

PLUMBING DIAGRAM
CRAN_RUMW_GECHL_012
DULUTH, MINNESOTA

SUBMITTAL:		
INT.	DATE:	DESCRIPTION:
TJT	12/16/25	REV A
MJM	02/26/26	REV B

CHECKED BY	MJM
EDGE SITE ID	S18113
EDGE PROJ. #	44861
SET TYPE	PRELIM
SHEET NUMBER	P-501

I:\44800\44861\Drawings\CAD\CDD\PHR\E-501.dgn

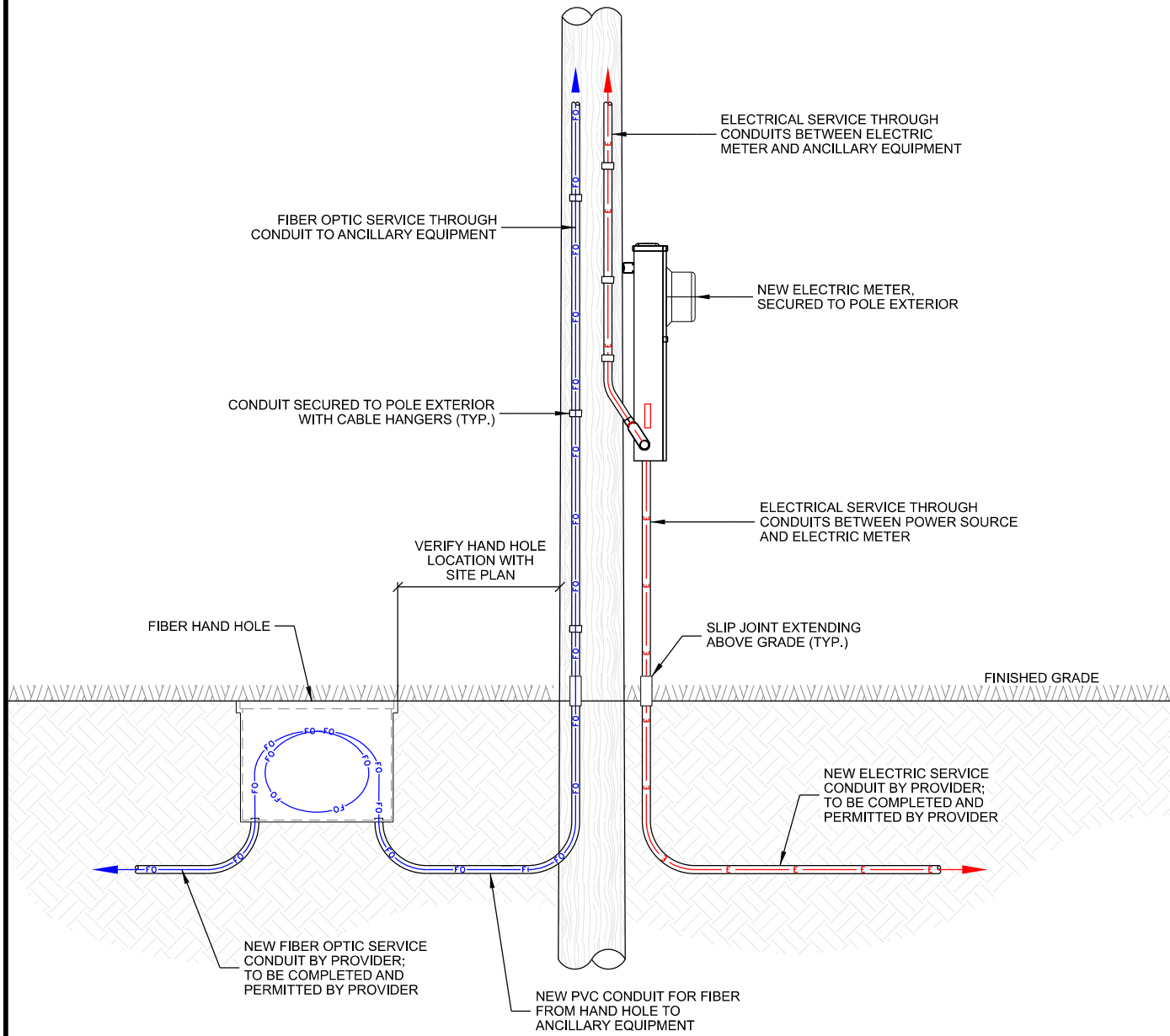

NOTE:
 1. THIS DETAIL IS A GENERAL SCHEMATIC; SEE SITE PLAN FOR ACTUAL EQUIPMENT ORIENTATION AND PLACEMENT

A RISER DIAGRAM

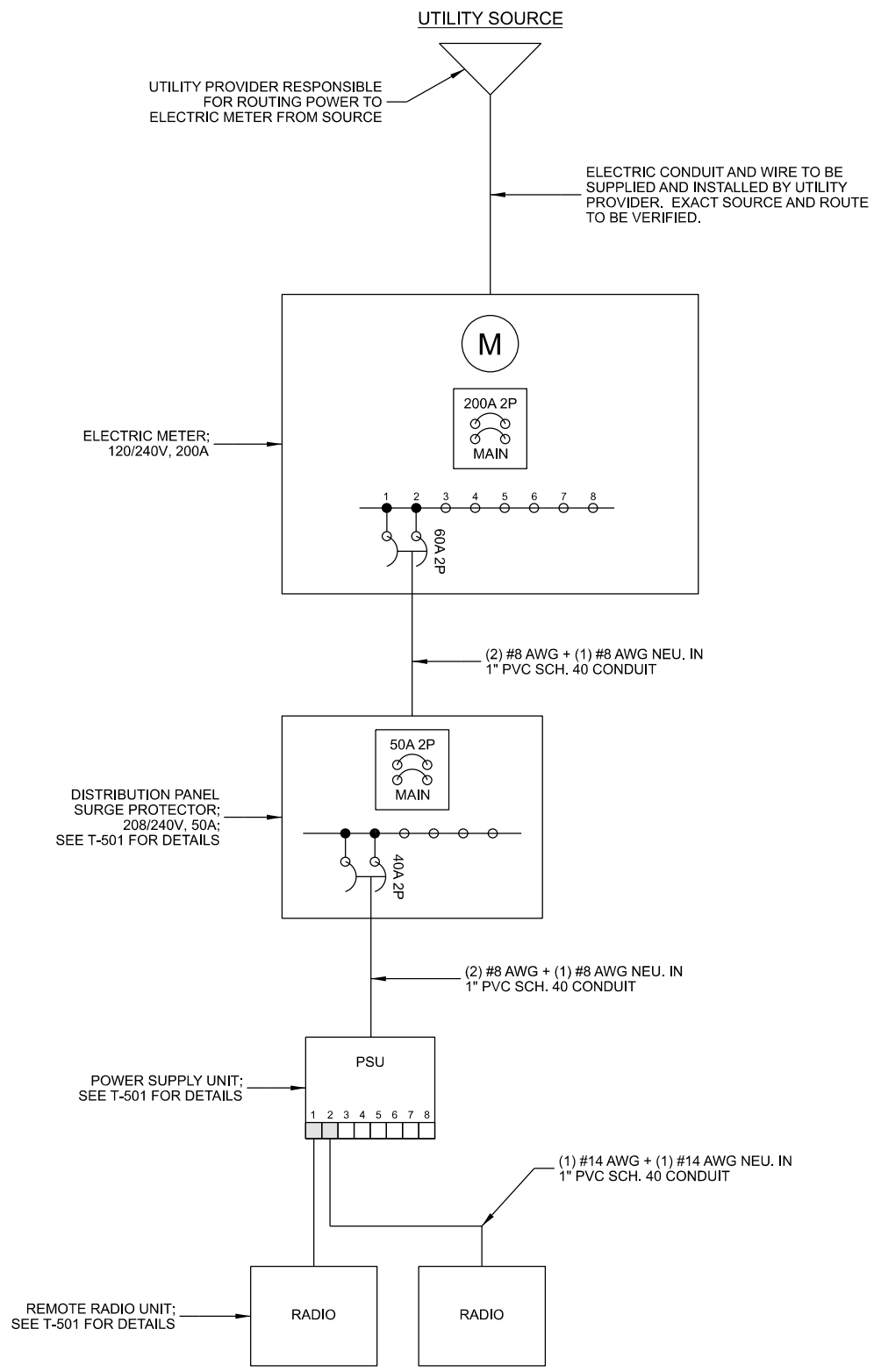

NOTES:
 1. ELECTRICAL CONTRACTOR TO VERIFY ELECTRICAL ROUTING WITH UTILITY COMPANY ON-SITE.
 2. VERIFY ELECTRICAL SOURCE VOLTAGE WITH MUNICIPAL UNMETERED DESIGN SPECIFICATION (SITE-SPECIFIC), AVAILABLE FROM CONSTRUCTION ENGINEER.
 3. THE GENERAL CONTRACTOR IS RESPONSIBLE TO VERIFY ALL REQUIRED CONDUCTOR AND CONDUIT SIZES DURING THE BIDDING PROCESS.
 4. PROVIDE ALL SERVICE CONDUIT, WIRE, METER, AND CONFIGURATION PER POLE OWNER REQUIREMENTS.

B ELECTRICAL ONE-LINE DIAGRAM

ENGINEER SEAL:
 I HEREBY CERTIFY THAT THIS PLAN, SPECIFICATION, OR REPORT WAS PREPARED BY ME OR UNDER MY DIRECT SUPERVISION AND THAT I AM A DULY LICENSED PROFESSIONAL ENGINEER UNDER THE LAWS OF THE STATE OF MINNESOTA.

SIGNATURE: _____
 TYPED OR PRINTED NAME: _____
 LIS. NO. _____
 DATE: _____

PRELIMINARY - NOT FOR CONSTRUCTION

**UTILITY DETAILS
 CRAN RUMW GECHL 012
 DULUTH, MINNESOTA**

SUBMITTAL:

INT.	DATE:	DESCRIPTION:
TJT	12/16/25	REV A
MJM	02/26/26	REV B

CHECKED BY	MJM
EDGE SITE ID	S18113
EDGE PROJ. #	44861
SET TYPE	PRELIM
SHEET NUMBER	E-501

LEGEND: (THIS SHEET)

- ▲ EXOTHERMIC CONNECTION
- MECHANICAL CONNECTION
- COMPRESSION CONNECTION

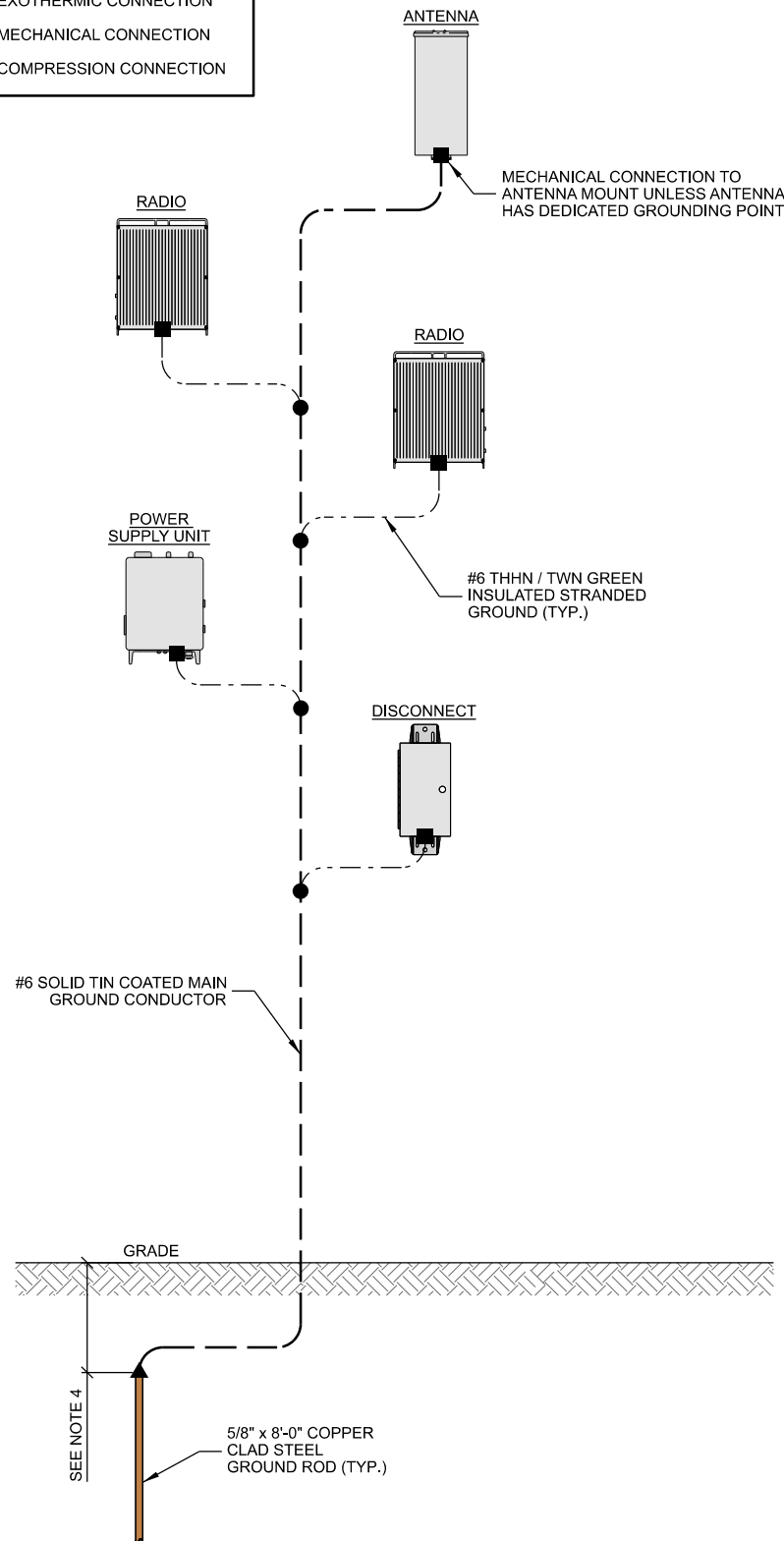

NOTES:

1. GROUNDING RISER FOR DIAGRAMMATIC PURPOSES ONLY. SEE ELEVATION DRAWINGS FOR EQUIPMENT/ANTENNA LOCATIONS AND QUANTITIES.
2. ALL RIGID GALV. STEEL TO BE GROUNDED AT BOTH ENDS USING GROUNDING BUSHINGS.
3. GROUND WIRE TO BE RUN WITHIN 1/2" SCH. 40 PVC.
4. DRIVE GROUND RODS TO A MINIMUM DEPTH OF 6" BELOW GRADE

A GROUNDING RISER DIAGRAM

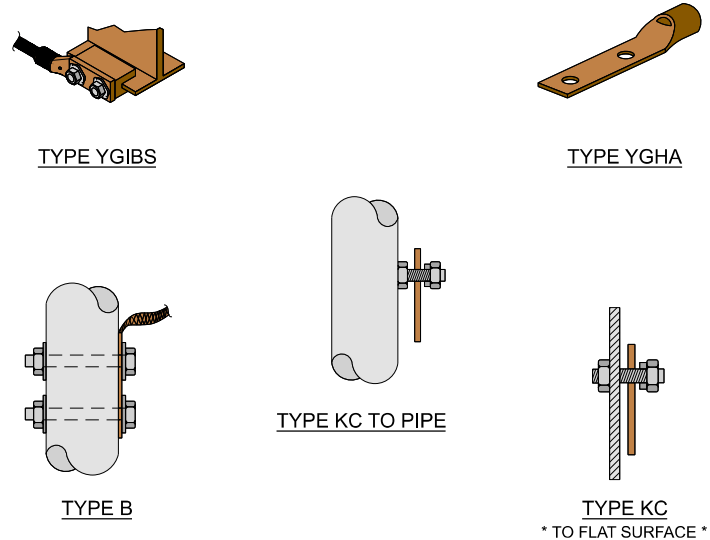

NOTES:

1. MECHANICAL "TYPES" SHOWN ARE EXAMPLES. CONSULT WITH PROJECT MANAGER FOR OTHER POSSIBLE TYPES OF MECHANICAL CONNECTIONS THAT CAN BE USED IN STANDARD OR SPECIALLY DESIGNED GROUNDING PLANS.
2. CONTRACTOR TO PROVIDE ALL REQUIRED MECHANICAL CONNECTIONS.

B MECHANICAL CONNECTIONS

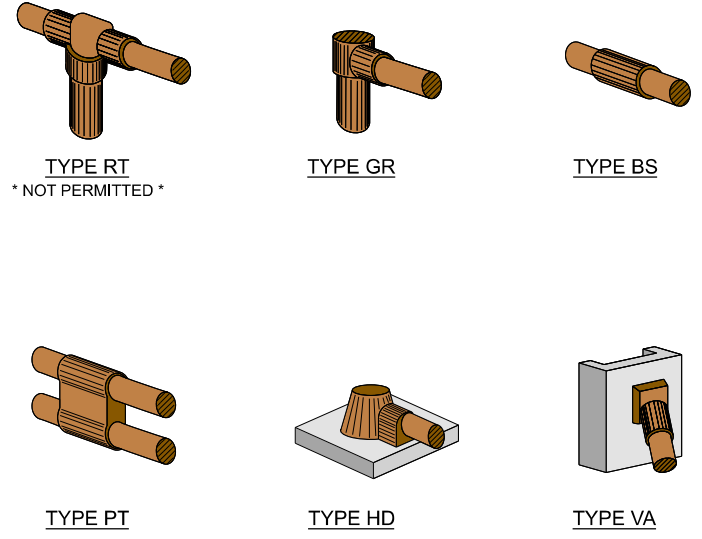

NOTES:

1. EXOTHERMIC "TYPES" SHOWN ARE EXAMPLES. CONSULT WITH PROJECT MANAGER FOR OTHER POSSIBLE TYPES OF EXOTHERMIC CONNECTIONS THAT CAN BE USED IN STANDARD OR SPECIALLY DESIGNED GROUNDING PLANS.
2. CONTRACTOR TO PROVIDE ALL REQUIRED EXOTHERMIC CONNECTIONS.

C EXOTHERMIC CONNECTIONS

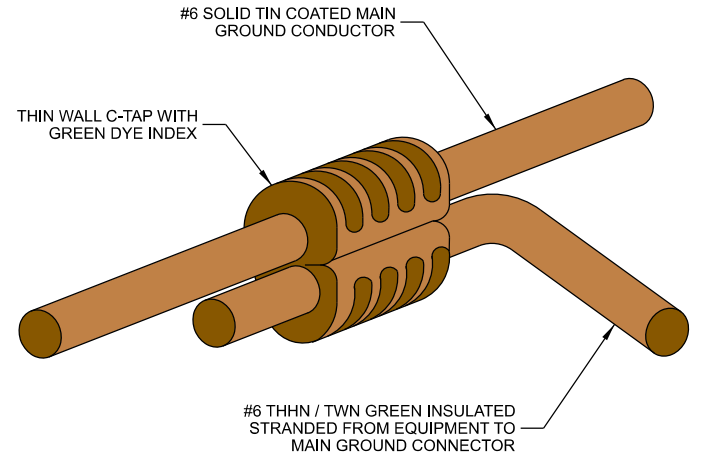

NOTES:

1. CONTRACTOR TO SURROUND COMPLETED CONNECTION WITH HEAT-SHRINK TUBING TO ENSURE WEATHER PROOF CONNECTION.
2. CONTRACTOR TO PROVIDE ALL REQUIRED COMPRESSION CONNECTIONS.

D COMPRESSION CONNECTION

THIS SPACE INTENTIONALLY LEFT BLANK

ENGINEER SEAL:
I HEREBY CERTIFY THAT THIS PLAN, SPECIFICATION, OR REPORT WAS PREPARED BY ME OR UNDER MY DIRECT SUPERVISION AND THAT I AM A DULY LICENSED PROFESSIONAL ENGINEER UNDER THE LAWS OF THE STATE OF MINNESOTA.
SIGNATURE: _____
TYPED OR PRINTED NAME: _____
LIS. NO. _____
DATE: _____

GROUNDING DETAILS
CRAN_RUMW_GECHL_012
DULUTH, MINNESOTA

SUBMITTAL:

INT.	DATE:	DESCRIPTION:
TJT	12/16/25	REV A
MJM	02/26/26	REV B

CHECKED BY	MJM
EDGE SITE ID	S18113
EDGE PROJ. #	44861
SET TYPE	PRELIM
SHEET NUMBER	E-503



RF EXPOSURE COMPLIANCE LETTER

Date: 10/22/2024

Band	Model	700	850	PCS	AWS	WCS	5 GHz	m
Antenna Power Input (W)	Gamma Nu OY9X360F16	0	0	240	240	0	0	0

PURPOSE OF THIS DOCUMENT

This Compliance Letter ("CL") confirms that the AT&T Mobility Centralized Radio Access Network (CRAN) or Small Cell node defined below meets Federal Communications Commission (FCC) RF exposure compliance requirements specified in 47 CFR §1.1310, provided that the actions specified in the "Compliance Actions" and "Completing this Compliance Letter Document" sections of this document are completed before the CRAN or Small Cell is placed into service.

DEFINITION OF SMALL CELLS INCLUDED IN THIS COMPLIANCE LETTER

The small cell antenna and its operating parameters covered by this Compliance Letter are:

- 1) **Antennas:** Gamma Nu OY9X360F16
- 2) **Lowest Antenna Centerline Height:** 25 feet above ground level
- 3) **Transmission Frequencies:** PCS/AWS
- 4) **Maximum Power Input per Frequency into (4G) Antenna (W):** 240/240
- 5) **Antenna Positions:** Top Mount (4G)
- 6) **Co-locators:** No other emitters are on pole/post/mounting location
- 7) **Separation Distance:** No publicly accessible locations (e.g., other poles, apartment balconies, rooftop, windows) within the space identified by XX=13 feet horizontal distance from the antenna and YY=03 feet beneath the antenna bottom tip.

Depiction:

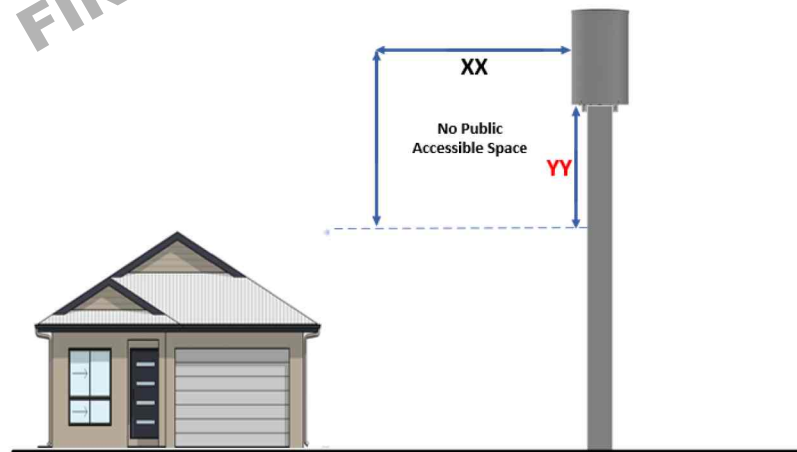

INVALIDATION OF THIS COMPLIANCE LETTER

This Compliance Letter becomes invalid if there are any RF modifications to the site, including but not limited to, changes to the conditions above, changes to antenna positions, additional sectors deployed, or other nearby emitters installed, etc.

The CRAN or Small Cell team managing the cell(s) to which this Compliance Letter applies must inform HQ RAN when any of the listed changes occur and request a new Compliance Letter study.

Class 2C Sites:

These are host-operated sites. AT&T RAN HQ will review EME reports provided by host companies and make a determination for compliance based on these reports. CL will not be required for host operated sites.

RF EXPOSURE COMPLIANCE ANALYSIS

RF exposure compliance was computationally evaluated using theoretical modeling contained in the FCC's OET Bulletin 65, considering a worst-case scenario in which peak power was transmitted 100% of the time. The MPE distance calculation incorporates cable loss of 0.5 dB for PCS and 0.5 dB for AWS bands, as applicable. The results, which are based on the FCC's maximum permissible exposure (MPE) limits for the general population, indicates the following MPE distance from the antenna.

Horizontal MPE Distance (in feet) 13'

COMPLIANCE ACTIONS

Design Changes

The following RF design changes are required by this CL to comply:

- **NA**

Signage Actions

Two AT&T 7" x 7" Caution sign(s) must be placed 3 feet beneath the antenna on the antenna's boresight or, in the event of an obstruction or other impediment to such placement, within 1 foot above or below that location. The Caution signs must specify that a distance of 13 feet must be kept from the antenna. The drawing in Appendix D of this document illustrates signage placement. Other options for deployment of signage may be discussed with HQ RAN Compliance Team if the pole/post owner refuses to allow signage to be posted on the pole or if other obstacles arise. The sign will inform the person of the potential for high exposure levels and provide a phone number to call and arrange for power to be removed from the antennas for the duration of work.



624 WATER STREET
PRAIRIE DU SAC, WI 53578



10 CHURCH CIRCLE
ANNAPOLIS, MD 21401



7900 XERXES AVE. S., 3RD FLR
BLOOMINGTON, MN 55431

ENGINEER SEAL:

I HEREBY CERTIFY THAT THIS PLAN, SPECIFICATION, OR REPORT WAS PREPARED BY ME OR UNDER MY DIRECT SUPERVISION AND THAT I AM A DULY LICENSED PROFESSIONAL ENGINEER UNDER THE LAWS OF THE STATE OF MINNESOTA.

SIGNATURE: _____

TYPED OR PRINTED NAME: _____

LIS. NO. _____

DATE: _____

** PRELIMINARY **
NOT FOR CONSTRUCTION

COMPLIANCE LETTER
CRAN_RUMW_GECHL_012
DULUTH, MINNESOTA

SUBMITTAL:

INT.	DATE:	DESCRIPTION:
TJT	12/16/25	REV A
MJM	02/26/26	REV B

CHECKED BY: MJM

EDGE SITE ID: S18113

EDGE PROJ. #: 44861

SET TYPE: PRELIM

SHEET NUMBER: **R-001**



Leasing Agreements

In anticipation of inquiries and concerns of employees, contract workers, and others that may enter areas in close proximity to the antennas (collectively, "Covered Persons"), leasing agreements should include language that obligates site owners to:

- 1) Show the antennas to all Covered Persons, as necessary;
- 2) Instruct all Covered Persons to remain at least 13 feet away from the antennas;
- 3) Instruct all Covered Persons to inform the pole/post owner if there is a need to get closer than 13 feet from the antennas;
- 4) Instruct all Covered Persons to coordinate work near the antennas with the pole/post owner;
- 5) Contact AT&T at 800-638-2822, opt. 9, 3, to arrange for the appropriate antenna(s) to be de-energized when needed if Covered Persons must work near the antennas, to provide confirmation to the Covered Persons when the antenna(s) have been de-energized, and to inform AT&T when it's safe to restore energy to the antennas.

In the event any RF modifications are made to a site, AT&T must also reassess the technical parameters of the small cells identified above to confirm compliance with the FCC exposure limits.

COMPLETING THIS CL

Review the **CRAN and Small Cell RF Safety Compliance Job Aid** for assistance with completing this Compliance Letter. The job aid may be retrieved from the Densification SharePoint using the link in Appendix C.

Actions to be taken by the HQ RF Safety Compliance Team

The HQ RAN RF Safety Compliance Team will collaborate with the C&E Densification N-PMO Team to address new issues with signage formatting, deployments, etc., as those issues arise during CRAN/Small Cell deployment.

Actions to be taken by the AT&T Market Site Acquisition PM (AMSAP)

The AMSAP shall complete the fields below for each site, but are NOT TO SIGN the section below.

The AMSAP may account for multiple sites/nodes by entering USIDs, FA#,s, and addresses for each in the spaces below.

CRAN or Small Cell USID: 182767
CRAN or Small Cell FA#: 14803941
Site Address: 2816-2820 BRYANT AVENUE SOUTH, MINNEAPOLIS, MN 55408



Actions to be taken by the RAN RF Design Engineer (RFDE)

The RFDE shall populate and approve the fields below, by adding a signature and date.

Name of CRAN or Small Cell RF Engineering POC: Kate Klungvedt
Title: MNP - RAN Design Engineer
Phone: 612-425-6461
Signature:
Date of Signature:

Upon completing the information above and signing, C&E or RFDE will upload the completed CL as instructed in Appendix B below.

Actions to be taken by the Mobility C&E National PMO

The Mobility C&E National PMO shall upload a copy of the unsigned CL into a SharePoint location managed by the Mobility C&E National PMO prior to site construction start. Following completion of site construction and signage actions, Mobility C&E PM will upload the signed copy of the CL into iComply, which will flow to FileNet, by following the instructions in Appendix B.

APPENDICES ON FOLLOWING PAGES

- APPENDIX A: Accessing the CRAN and Small Cell CL Library
- APPENDIX B: Naming Conventions for Uploading Completed CLs into iComply
- APPENDIX C: Densification SharePoint Link
- APPENDIX D: RF Signage Placement



ENGINEER SEAL:
 I HEREBY CERTIFY THAT THIS PLAN, SPECIFICATION, OR REPORT WAS PREPARED BY ME OR UNDER MY DIRECT SUPERVISION AND THAT I AM A DULY LICENSED PROFESSIONAL ENGINEER UNDER THE LAWS OF THE STATE OF MINNESOTA.

SIGNATURE: _____

TYPED OR PRINTED NAME: _____

LIS. NO. _____

DATE: _____

COMPLIANCE LETTER
CRAN RUMW GECHL 012
DULUTH, MINNESOTA

SUBMITTAL:

INT.	DATE:	DESCRIPTION:
TJT	12/16/25	REV A
MJM	02/26/26	REV B

CHECKED BY: MJM

EDGE SITE ID: S18113

EDGE PROJ. #: 44861

SET TYPE: PRELIM

SHEET NUMBER: **R-002**



APPENDIX A: Accessing the CRAN and Small Cell CL Library

A library of previously-issued CLs may be consulted to determine whether one of them is applicable to a new deployment.

Use this link to access previously issued Compliance Letters: [MPE Studies Folder](#). If you do not have access, you can request it upon clicking the link above.

**** Access is not granted to Non-Staff Supplemental Non-Payroll Workers (NSS NPWs). ****

1. If all the conditions in a CL are congruent with the conditions for a prospective new deployment, the CL may be applied according to guidance given in the main body of this document.
2. If changes, e.g., increase in power, to an existing CL would appear to make it applicable to a new deployment, a request for modification may be made to HQ RAN Compliance Team.
3. If no usable CL is found in the library, a request for a new CL must be made through the CRAN RF Safety Compliance mailbox (g13613@att.com)

APPENDIX B: Naming Conventions for Uploading Completed CLs into iComply

CLs completed by the field must be uploaded into iComply using the following naming convention:

1. Signed CLs will be uploaded into iComply
2. If the multiple site/node option is used, the completed CL must be uploaded into all applicable locations.
3. Following file naming convention will be used for CLs when uploading into iComply
 - a. RFS Cert_SC_FA_USID_MMDDYY (Applies to Small Cells)
 - b. RFS Cert_CRAN_FA_USID_MMDDYY (Applies to CRAN)

APPENDIX C: Densification SharePoint Link

The Densification MPE Studies SharePoint link may be consulted to access:

1. CRAN and Small Cell Class 2 CL Request process flow
2. CRAN and Small Cell RF Safety Compliance Job Aid

[Job Aids and MPE Templates](#)



APPENDIX D: RF Signage Placement

Signage **must be ordered from ACP Intl Signs Inc.**, according to the guidance in Section 6.2 "ACP Intl signs ordering process (CRAN) in ATT-790-202-062 DAS (Distributed Antenna System) and CRAN (Centralized Radio Access Network) Signage Standard."

<http://apex.web.att.com/bookview/bookview.jsp?bookname=ATT-790-202-062&fulltext>

Existing sites going through RF Modifications (i.e. carrier, antenna or 5G mmWave add, etc.) must be evaluated to determine if a sign change is needed. Signs must be changed to comply with the requirements in this CL in the following instances:

1. The old sign is smaller than 8.25" in height OR width; OR
2. The old sign alert level (e.g., Notice, Caution) is less than the alert level required by this CL.

If the old sign does not need to be changed, but the "Horizontal Exposure Distance" value on the sign is different than the Horizontal Exposure Distance value in this CL, update the MPE distance on the old sign by attaching the appropriate sticker with the new value over the old value.

Ordering part number for this sign is: "R801RPE"

1. Sign Dimensions: height=7", width=7";
2. Use the supplied number pad to enter the number **13** into the blank space as shown in the sign diagram.

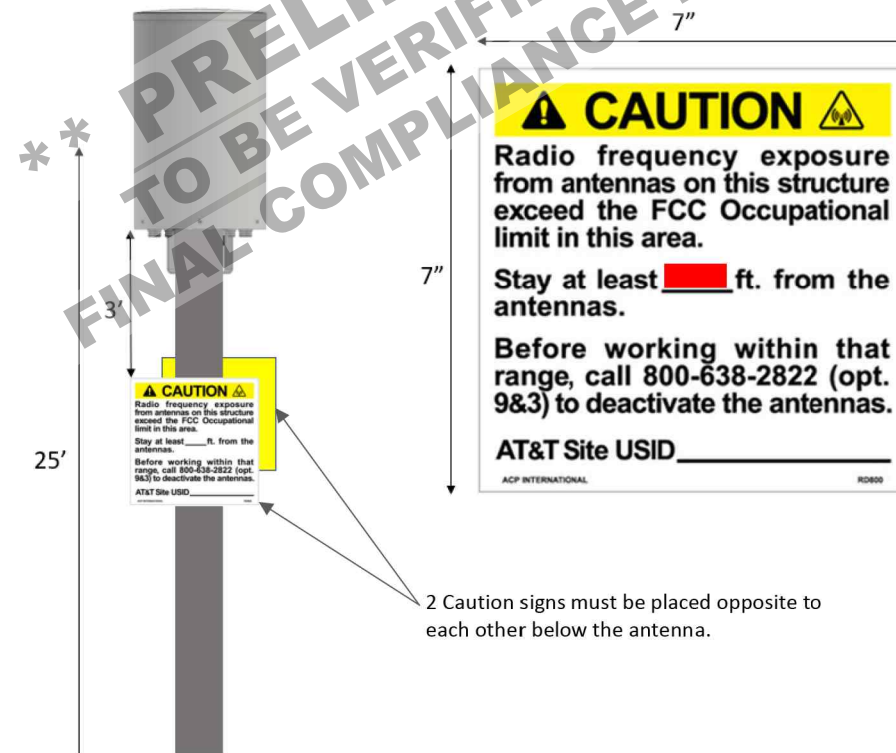

2 Caution signs must be placed opposite to each other below the antenna.

ENGINEER SEAL:
I HEREBY CERTIFY THAT THIS PLAN, SPECIFICATION, OR REPORT WAS PREPARED BY ME OR UNDER MY DIRECT SUPERVISION AND THAT I AM A DULY LICENSED PROFESSIONAL ENGINEER UNDER THE LAWS OF THE STATE OF MINNESOTA.

SIGNATURE: _____
TYPED OR PRINTED NAME: _____
LIC. NO.: _____
DATE: _____

COMPLIANCE LETTER
CRAN_RUMW_GECHL_012
DULUTH, MINNESOTA

SUBMITTAL:		
INT.	DATE:	DESCRIPTION:
TJT	12/16/25	REV A
MJM	02/26/26	REV B

CHECKED BY:	MJM
EDGE SITE ID:	S18113
EDGE PROJ. #:	44861
SET TYPE:	PRELIM
SHEET NUMBER:	R-003

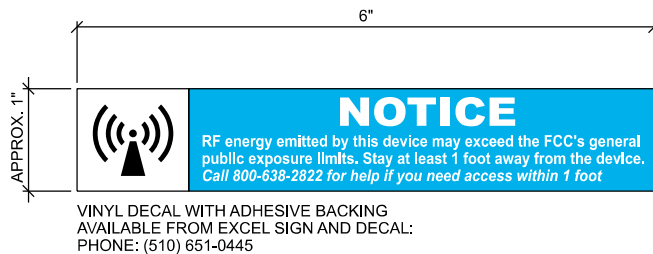

A NOTICE DECAL SIGN

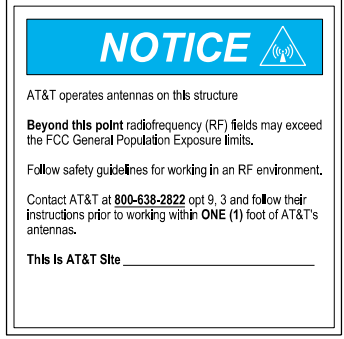

B CRAN NODE RF SIGN PLACEMENT

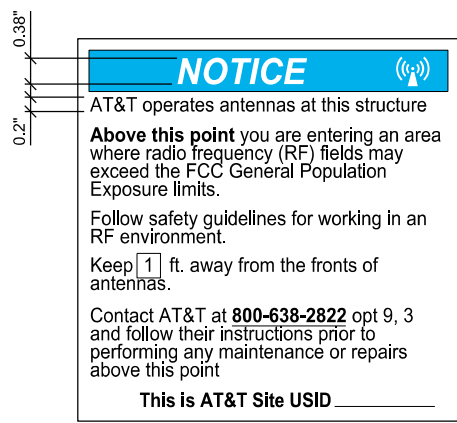

C CRAN RF NOTICE SIGN

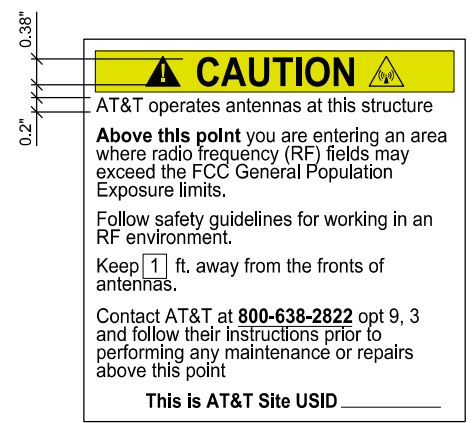

D CRAN RF CAUTION SIGN

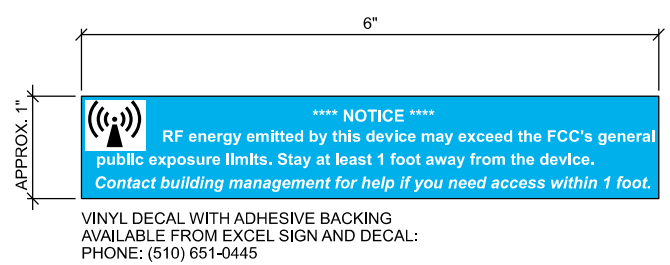

E NOTICE DECAL SIGN

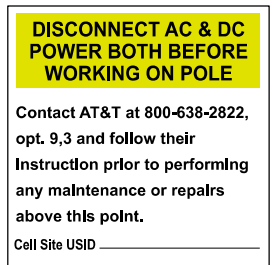

F CRAN POLE POWER DISCONNECT SIGN

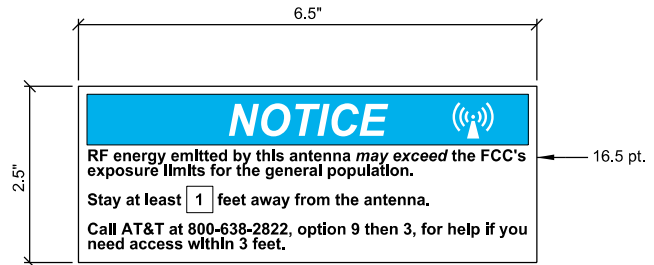

G RF NOTICE SIGN

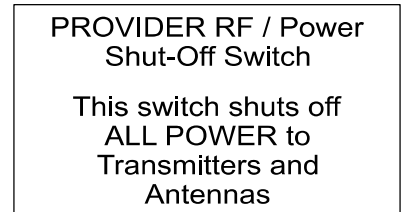

H RF/POWER DISCONNECT SIGN

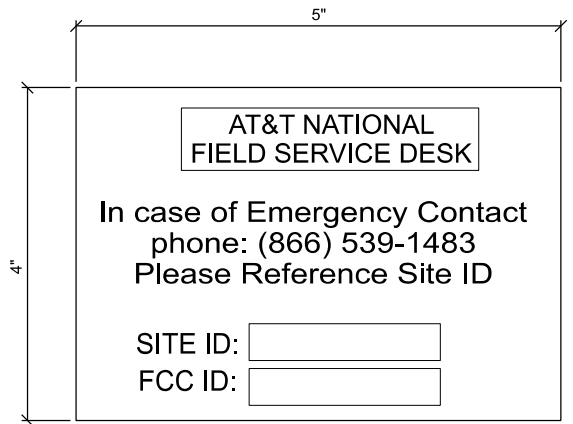

I POLE OWNER SIGN

ENGINEER SEAL:
I HEREBY CERTIFY THAT THIS PLAN, SPECIFICATION, OR REPORT WAS PREPARED BY ME OR UNDER MY DIRECT SUPERVISION AND THAT I AM A DULY LICENSED PROFESSIONAL ENGINEER UNDER THE LAWS OF THE STATE OF MINNESOTA.

SIGNATURE: _____
TYPED OR PRINTED NAME: _____
LIS. NO. _____
DATE: _____

PRELIMINARY - NOT FOR CONSTRUCTION

SIGN DETAILS
CRAN_RUMW_GECHL_012
DULUTH, MINNESOTA

SUBMITTAL:

INT.	DATE:	DESCRIPTION:
TJT	12/16/25	REV A
MJM	02/26/26	REV B

CHECKED BY	MJM
EDGE SITE ID	S18113
EDGE PROJ. #	44861
SET TYPE	PRELIM
SHEET NUMBER	R-501

From: [Chris Lee](#)
To: [planning](#)
Subject: RE: AT&T Small cell installment 2904 Parkwood Lane
Date: Wednesday, April 1, 2026 9:10:00 AM

-----Original Message-----

From: Janet Peterson [REDACTED]
Sent: Tuesday, March 31, 2026 7:36 PM
To: [planning <planning@DuluthMN.gov>](mailto:planning@DuluthMN.gov)
Subject: AT&T Small cell installment 2904 Parkwood Lane

A Zoning Notice sign was put up with our address on it regarding AT&T small cell tower being put up on our property. We have never talked to AT&T regarding this or anyone from the Planning Commission. We are completely against any cell tower put up on our property or in our neighborhood.

How is a permit filed with our address on it without our permission? How is our address put on a sign posted in public on a neighborhood light pole without our permission?

Since this is our Home and our private property, we feel we should have been notified with this information before a sign is posted in public. We were quite shocked to read our address on the sign!

We would appreciate hearing from someone with information on how to straighten this matter out, get our address off any permit and stop a cell tower from being put on our private property.

Thank you

Janet and Michael Peterson

2904 Parkwood Lane
Duluth, MN. 55811
218-591-4813
Sent from my iPhone

