

LICENSE AGREEMENT BETWEEN CITY OF DULUTH AND DULUTH BACK COUNTRY HORSEMENT OF MINNESOTA

THIS LICENSE AGREEMENT (this "Agreement") is entered into by and between DULUTH BACK COUNTRY HORSEMEN OF MINNESOTA, a Minnesota nonprofit corporation ("Duluth BCH"), and the CITY OF DULUTH, a municipal corporation created and existing under the laws of the State of Minnesota (the "City").

WHEREAS, the City is committed to providing recreational opportunities for the citizens of Duluth and enhancing the quality of the City's open spaces.

WHEREAS, Duluth BCH is a nonprofit corporation with the mission to educate the general public, and to develop and maintain, preserve and protect public lands and parks for equestrian use in and around the Greater Duluth Minnesota area.

WHEREAS, the City wishes to create a revocable, non-exclusive license in favor of Duluth BCH to allow Duluth BCH to complete the Trail Maintenance Project in accordance with the terms and conditions of this Agreement and consistent with the DWP Mini Master Plan.

WHEREAS, Duluth BCH has represented itself as fully capable of completing the Trail Maintenance Project and as qualified and willing to perform the Trail Maintenance Project.

NOW, THEREFORE, in consideration of the mutual covenants and conditions contained in this Agreement, the receipt and sufficiency of which is acknowledged, the parties agree as follows:

I. THE LICENSE.

A. The license granted under this Section pertains to the following trails located within the City of Duluth known by the following names: Amity Creek Trail; Duluth Winnipeg Pacific ("DWP") Trail; Clyde Connector Trail; Magney Snively Trails; Willard Munger State Trail (collectively "Trails").

B. Subject to the terms and conditions set forth in this Agreement, the City grants to Duluth BCH a revocable, non-exclusive license to enter onto the Trails for the limited purpose of completing the Trail Maintenance Project. The Trail Maintenance Project shall be completed by Duluth BCH, its employees, agents and volunteers. The Trail Maintenance Project shall be at no cost to the City, except as otherwise set forth in this Agreement, or as may be approved by the City, in the City's sole discretion. This Agreement does not permit Duluth BCH to construct new sections of the Trail.

B. Duluth BCH acknowledges and understands that the Trails are public property and the cooperation of all users and coordination of activities is required. This cooperation includes ingress, egress and use of amenities and related improvements. The City's Manager of Parks and Recreation or his or her designee (the "Manager") shall ultimately determine the appropriate use of the Trails and shall decide any disputes between Duluth BCH and any other users of the Trails.

C. Duluth BCH use of the Trails shall in no way limit or restrict the City's or the public's use of the Trails. The City shall continue to enjoy unlimited access to the Trails during the Term. Notwithstanding the foregoing, Duluth BCH may temporarily close off a section of the Trails for public safety reasons when performing the Trail Maintenance Project by providing appropriate signage and/or fencing to notify the public of the activities occurring.

D. City shall determine, in its sole discretion, when the Trails, or portions of the Trails, are open or closed for public use. Nothing in this Agreement shall prevent Duluth BCH from: (i) sending notifications to its members and the public regarding the City's decisions to open and close the Trails, or portions of the Trails; or (ii) advising its members to refrain from using the Trails, or portions of the Trails, even then it is open for public use, in order to prevent or minimize damage to the Trails.

E. Duluth BCH shall be responsible for all of its costs and employee compensation in connection with the Trail Maintenance Project, including but not limited to payroll, workers compensation, rental or purchase of equipment and all other expenses, except as otherwise set forth in this Agreement, or as may be approved by the City, in the City's sole discretion. Duluth BCH may utilize the City's Volunteer Toolshed in accordance with the then-current policies governing use of the Volunteer Toolshed. Duluth BCH staff members and volunteers shall be employees or agents solely of Duluth BCH and not employees or agents of the City.

F. Duluth BCH will work on the Trail Maintenance Project in coordination with the City's Parks and Recreation Department, with the Manager serving as the primary contact for the City. Duluth BCH shall notify the City in writing no less than one week in advance of any planned activities that will close a segment of the Trails or substantially impact use of any portion of the Trails. However, the Manager may grant Duluth BCH permission to work within the Trails with less than one week's notice in the Manager's sole discretion. In the event that the City determines, in its sole discretion, that the planned activities will substantially interfere in any way with other activities planned for that time period (either in the Trails or surrounding areas), Duluth BCH shall reschedule its planned activities for a time that is acceptable to the City. In the event of a major wind or other event causing substantial damage or blockage to one or more portions of the Trails, the City may indefinitely suspend Duluth BCH's access to the affected portion(s) of the Trails by providing written notice to Duluth BCH. In such an event, and as the City's resources allow, the City will reopen the affected portion(s) of the Trails in the City's sole discretion.

G. The City may be working within the Trails or nearby areas during the Term, and Duluth BCH activities shall not interfere with the City's activities.

H. Duluth BCH acknowledges that portions of the Trails are on property owned by the State of Minnesota and managed by St. Louis County (the "State Property"). Duluth BCH must comply with (i) this Agreement, (ii) all applicable rules, regulations and laws, and (iii) the terms and conditions of applicable trail authorization agreement(s) now existing or entered into from time to time between the City and the State of Minnesota and/or St. Louis County (collectively, the "State Authorizations"). In the event that any terms and conditions of any of the State Authorizations contradict any terms or conditions of this Agreement, the terms and conditions set forth in those authorizations shall supersede the terms and conditions set forth in this Agreement.

I. While this Agreement grants Duluth BCH permission to perform the Trail Maintenance Project, it does not obligate Duluth BCH to perform the Trail Maintenance Project.

- II. TERM OF THIS AGREEMENT. Notwithstanding the date of execution of this Agreement, the term of this Agreement shall commence on or about June 15, 2026, and shall continue through January 15, 2029, unless earlier terminated as provided in this Agreement (the “Term”).

III. LICENSE ACTIVITIES.

A. Authorized Activities on Trail Maintenance Project. Duluth BCH may, under the conditions set forth in this Agreement and consistent with the Trail Specifications (defined below), engage in the following activities for the purpose of completing the Trail Maintenance Project, without additional approval from the City (unless otherwise required by this Agreement):

1. Build and maintain drainage structures to prevent loss of soil through erosion.
2. Keep structures such as bridges, foot logs, puncheons, rock culverts, etc. safe for use.
3. Clear the Trails of debris and obstructions to allow for safe use.
4. Maintain the surface of the Trails to provide an adequate walking and riding surface, free from obstacles or hazards, which maintenance duties include the repair or modification of the tread in a manner that is consistent with the trail’s character and difficulty.
5. Cut and remove brush, trees and other vegetation to define and protect the established tread of the Trails.

B. Regulation of Activities – Safety Provisions.

1. Duluth BCH may use chainsaws, track wheelbarrows, lawnmowers, weed whips, brush cutters, snowmobiles, saws, drills, mini-excavators, and other mechanized equipment (collectively, the “Mechanized Equipment”) to perform the Trail Maintenance Project, but must adhere to the following rules when using the Mechanized Equipment:

a. Only individuals designated by Duluth BCH as a “chainsaw operator” may operate chainsaws. Duluth BCH shall adhere to Occupational Safety and Health Administration (“OSHA”) requirements for working safely with chainsaws, including with respect to its volunteers.

b. Only individuals designated by Duluth BCH as a “machine operator” may operate mechanized equipment. Duluth BCH shall adhere to OSHA requirements associated with the use of wheel or track propelled equipment, including with respect to its volunteers.

c. Only individuals designated by Duluth BCH as a “power tool operator” may operate power saws (circular saw), power pole saw, and brush cutters tools. Duluth BCH shall adhere to OSHA requirements associated with the use of hand and power tools, including with respect to its volunteers.

d. The Manager, in their sole discretion, retains the right to prohibit any type of equipment from being used by Duluth BCH on the Trails.

2. Duluth BCH may not use chemical methods to remove brush, trees, and other vegetation, except (i) when removing or attempting to remove invasive species, and (ii) with written approval from the City. If Duluth BCH wishes to use chemical removal methods, it must submit a written request in advance. The City may approve or refuse a request to use chemical removal methods in its sole discretion. In the event chemical removal methods are authorized, Duluth BCH shall (i) use only the specific chemicals and methods authorized by the City, in the approved quantities; (ii) only disperse the chemical(s) on the invasive species identified in the

City's written approval; and (iii) use, transport and store the chemical(s) in accordance with applicable law and consistent with all guidelines imposed by the City.

3. All brush and other vegetation shall be slashed and dispersed on site so that it sits no higher than 18" off the ground with cut ends pointed away from the active trail tread whenever possible. All cut and/or slashed vegetation shall be dragged away from the active trail tread so that it is out of sight from users (but within the trail corridor, which varies among different sections of the Trails). Wood chips may not be left in piles higher than four inches off the ground. Cut and/or slashed vegetation, including wood chips, shall not be deposited into suspected wetlands, lowlands, or drainage ways and must be disposed of in an upland location.

4. All cut trees shall be left on site, but, to the extent possible, dragged away from the active trail tread (but within the trail corridor, which varies among different sections of the Trails) so that, to the extent possible, they are out of sight from users. All tree stumps greater than 6" in diameter shall be left no higher than three inches off the ground. All woody vegetation less than 6" in diameter that are within the active trail tread or fall zone shall be removed as to not leave any sharp edges or protrusions. The removal and cutting of trees and vegetation under this Section III.B.4. shall be consistent with the trail's character and degree of difficulty.

5. Standing or live fallen trees designated as "special tree species" under the City's Code Chapter 35-26(i), as it may be amended or replaced from time to time, greater than six inches in diameter measured at breast height, require written approval from the Manager before removal; except that if a standing or live fallen tree designated as "special trees species" is physically blocking the Trails, it may be removed from the Trails without the prior written approval of the Manager. At the time of execution of this Agreement the "special tree species" listed in Chapter 35-26(i) include the following: white pines, red or Norway pines, white cedars, white spruces, eastern hemlocks, sugar maples, American basswoods, American elms, yellow birches and all oak species. It is the responsibility of Duluth BCH to obtain the current list of species included in "special tree species" under the City's Code at the time of tree removal. All other trees may be removed without written permission. Duluth BCH shall submit tree removal requests in writing to the City prior to removal of any tree requiring the Manager's approval, which the City may approve or reject in its sole discretion.

6. Duluth BCH must provide personal protective equipment necessary or adequate for all activities on the Trails. The City will not provide recommendations and/or direction as to what, if any, personal protective equipment should be used by individuals working on the Trail Maintenance Project.

7. Any Duluth BCH activities not approved by the Manager or failure to adhere to the safety provisions of this agreement may be grounds for finding Duluth BCH material breach of this Agreement.

8. Duluth BCH is not permitted to widen the active trail tread or the surrounding buffer areas beyond what is appropriate for the trail rating and characteristics. Duluth BCH shall perform all duties and activities authorized under this Agreement consistent with the Mini Master Plan and/or at the direction of the City.

9. Duluth BCH shall only perform the Trail Maintenance Project during regular park hours, generally 6 a.m. to 10 p.m., with the exception of winter grooming. Any activities performed outside of this timeframe requires written permission from the Manager.

C. ATV Use. Duluth BCH may, under the following conditions, use an all-terrain vehicle and other mechanized equipment which include mini-excavators and tracked wheelbarrows (“ATV”) to access the Trails solely for the purpose of completing the Trail Maintenance Project:

1. ATV use shall be limited to (i) the Trails, and (ii) approved ski trails, snowmobile trails, and forest roads. No other trail or off-trail use can have ATV traffic unless such use is approved by the City in advance pursuant to a written request submitted to the City. If such a request is approved, the City shall transmit permission in writing or via email. The City reserves the right to deny any such requests. Overland cutting is prohibited unless approved in writing by the Manager in advance.

2. Speed of ATVs is limited to 10 miles per hour or less.

3. ATV users must yield to people and pets.

4. ATV use is limited to times when the trails are dry. ATV use is prohibited when the trails are wet and/or muddy. If Duluth BCH causes any rutting on the Trails or any other damage to a trail surface, Duluth BCH shall promptly restore the rutted or damaged portion of the trail to its pre-existing condition.

5. ATV use on off-trail locations shall be minimized to the greatest extent possible and used to bypass bridges, boardwalk, and terrain where the ATV cannot be safely operated. If Duluth BCH causes any rutting or any other damage to an off-trail surface, Duluth BCH shall promptly restore the rutted or damaged portion of the off-trail surface to its pre-existing condition.

6. ATVs may be used only to haul tools, materials, and equipment. ATVs may not be used for sightseeing or other purposes.

7. When authorized to use ATVs, Duluth BCH shall only use ATVs during daylight hours and may not use ATVs when it is dark.

8. ATVs must be clearly labeled or otherwise visibly displayed with a sticker or other device acceptable to the City to notify the public that such ATV use is specially authorized.

9. All ATVs used to complete the Trail Maintenance Project must be supplied by Duluth BCH or its designated volunteers.

D. VOLUNTEER USE. Duluth BCH may use volunteers to perform work on the Trail Maintenance Project and, in such event, must supervise volunteers in accordance with the requirements under this Agreement, as well as adhere to the following:

1. Duluth BCH must provide a trail steward or crew leader to supervise volunteers at all times and submit their name and contact information to the Manager. The type of supervision will be based on type of work being performed and skill level of the volunteer, ranging from direct on-sight supervision to indirect supervision.

2. Duluth BCH must train and supervise volunteers in appropriate construction techniques; and

3. Duluth BCH must provide volunteers with the appropriate tools to perform the Trail Maintenance Project.

E. CONFORMANCE TO SPECIFICATIONS. Duluth BCH shall complete the Trail Maintenance Project in a professional and diligent manner. All work shall be done in accordance with: (i) the Mini Master Plan, (ii) the Construction Specifications dated January 18, 2019 and boardwalk, bridge, and erosion details, all attached as Exhibit A, except as may otherwise be approved in writing by the Manager; and (iii) the Trails Specification Matrix attached as Exhibit B (collectively, as they may be amended from time to time, the "Trail Specifications"). In the event Duluth BCH performs work that does not conform to the Trail Specifications, the Manager may require that Duluth BCH fix the non-conforming work, including revegetation in the event vegetation or trees are removed by Duluth BCH without proper authorization. The Trail Specifications shall not be amended without the prior written approval of the Manager. In the event of any conflict between this Agreement and the Trail Specifications, the Trail Specifications shall control.

IV. TERMINATION.

A. The City may terminate this Agreement without cause by providing written notice to Duluth BCH. Duluth BCH may terminate this Agreement without cause by providing at least fourteen (14) calendar days' written notice to the City.

B. The City may terminate this Agreement for the material breach by Duluth BCH of any provision of this Agreement if such breach is not cured to the satisfaction of the City within ten (10) days of delivery of a written notice by the City (or such longer time as specified in the notice). The notice shall identify the breach and the actions necessary to remedy the breach.

C. The City may terminate this Agreement immediately on written notice to Duluth BCH if the City believes in good faith that the health, welfare, or safety of occupants or neighbors of the Trails would be placed in immediate jeopardy by the continuation of this Agreement.

V. REPRESENTATIONS AND WARRANTIES.

A. The City makes no representation that the Trails is suitable for any particular purpose or specific uses and Duluth BCH accepts the Trails in "as is" condition without representations or warranties of any kind.

B. Duluth BCH represents and warrants that it shall perform its duties in a professional and diligent manner in the best interests of the City and in compliance with all applicable laws.

C. Duluth BCH represents and warrants that Duluth BCH and all personnel and volunteers working on the Trail Maintenance Project shall have sufficient training and experience to perform the duties set forth herein and are in good standing with all applicable licensing requirements.

VI. RESTORATION.

A. Duluth BCH shall exercise reasonable care in performance of the Trail Maintenance Project.

B. Except as explicitly permitted by this Agreement, Duluth BCH shall not make any alterations or improvements to the Trails without the prior written consent of the City and then only upon the terms and conditions which may be imposed by the City. Prior to expiration of the Term, Duluth BCH shall repair any damage caused by Duluth BCH, its employees, servants, volunteers, agents, contractors, invitees, and licensees to the equivalent of its condition prior to the damage caused by Duluth BCH, or better, or, upon demand, pay to the City the reasonable costs incurred by the City to repair any damage done by Duluth BCH, its employees, servants, volunteers, agents, contractors, invitees, and licensees.

VII. HOLD HARMLESS. To the fullest extent permitted by law, Duluth BCH shall defend, indemnify, and hold the City and its employees, officers, and agents harmless from and against any and all cost or expenses, claims, damages, losses, or liabilities, including but not limited to, reasonable attorneys' fees and expenses in connection with any claims resulting from: (a) Duluth BCH breach of this Agreement; (b) Duluth BCH negligence or misconduct or that of its members, employees, agents, volunteers, subcontractors, or contractors in completing any portion of the Trail Maintenance Project, including but not limited to design and signage; (c) any claims arising in connection any act or failure to act of any Duluth BCH member, employees, agents, volunteers, subcontractors, contractors, or anyone for whose acts Duluth BCH may be liable, in connection with the Trail Maintenance Project; or (d) the use of any materials supplied by Duluth BCH to the City unless such material was modified by the City and such modification is the cause of such claim. Duluth BCH is not responsible for maintenance or other work on the Trails unless it is performed under the direction or control of Duluth BCH. The obligations shall further include the obligations to defend, indemnify, and hold harmless the City in all matters where claims of liability against the City are alleged to be or could be found to arise out of acts or omissions of Duluth BCH, or are passive, derivative, or vicarious of the negligent or intentional acts or omissions of Duluth BCH, or arise out of or relate to the Trail Maintenance Project or Duluth BCH's negligent, intentional, or wrongful acts or omissions. The obligations to defend, indemnify, and hold harmless shall be triggered upon the assertion of a claim for damages against City. On ten days' written notice from City, Duluth BCH will appear and defend all lawsuits against City growing out of such injuries or damages using counsel acceptable to City. Duluth BCH shall not have the obligation to indemnify the City for its intentional, willful or wanton acts. This section shall survive the termination of this Agreement for any reason.

In no event shall the language of this Agreement constitute or be construed as a waiver or limitation for either Party's rights or defenses with regard to each Party's applicable sovereign, governmental, or official immunities and protections as provided by federal and state constitution or laws.

VIII. INSURANCE. Duluth BCH shall provide and maintain in full force and effect during the life of this Agreement the following minimum amounts of insurance:

- (1) Workers compensation insurance in accordance with applicable law.
- (2) Commercial General and Automobile Liability Insurance with limits not less than \$1,000,000 Single Limit that shall provide for the following: Liability for Premises, Operations, Completed Operations, Independent Contractors, and Contractual Liability. DULUTH BCH may meet the minimum amount of insurances as required above by obtaining an Umbrella policy with a "form following" provision. Insurance coverage shall include premises and operations coverage, independent contractors - protective contingent liability, personal injury, contractual liability

covering the indemnity obligations set forth herein, and products – completed operations. The City does not represent or guarantee that these types or limits of coverage are adequate to protect the DULUTH BCH's interests and liabilities.

City shall always be named as an Additional Insured under the Commercial General and Automobile Liability Policies, and Duluth BCH will provide Certificate of Insurance evidencing such coverage with 30-days' notice of cancellation provision included.

Duluth BCH shall provide City with Certificate(s) of Insurance evidencing the required insurance coverage - with 30-day notice of cancellation, non-renewal, or material change provisions included - prior to the execution of this Agreement and a certificate showing continued maintenance of such insurance shall be on file with the City during the term of this Agreement. City reserves the right to require Duluth BCH to increase the coverages set forth above and to provide evidence of such increased insurance to reflect the municipal liability limits set forth in Minn. Stat. § 466.04, as amended from time to time.

IX. INDEPENDENT CONTRACTOR. Nothing contained in this Agreement is intended or should be construed in any manner as creating or establishing the relationship of co-partners between the parties or as constituting Duluth BCH or Duluth BCH personnel as an agent, representative, or employee of the City for any purpose or in any manner whatsoever. Duluth BCH and its employees shall not be considered employees of the City and any and all claims that may or might arise under the Workers' Compensation Act of the State of Minnesota on behalf of Duluth BCH employees or agents while so engaged, shall in no way be the responsibility of the City.

X. ASSIGNMENT. Duluth BCH shall not in any way assign or transfer its rights or interests under this Agreement. However, Duluth BCH may hire subcontractors to work on the Trail Maintenance Project. Any subcontractor hired by Duluth BCH shall procure the required insurance coverages as described in Section VIII above and provide proof of coverage to the City prior to conducting any work on the Trails. Duluth BCH shall remain primarily responsible for all work performed by any subcontractor.

XI. LAWS, RULES AND REGULATIONS.

A. Duluth BCH shall conduct its activities related to the Trail Maintenance Project in strict compliance with the United States Constitution and with the applicable laws, rules, and regulations of the United States, State of Minnesota, St. Louis County, City of Duluth, including, but not limited to, all laws, rules, and regulations relating to accessibility standards under the Americans with Disabilities Act. Duluth BCH shall not unlawfully discriminate and shall comply with all applicable federal and state laws regarding non-discrimination.

B. Duluth BCH shall procure, at Duluth BCH's expense, all licenses, permits, approvals and permissions necessary for carrying out its obligations under this Agreement and completing the Trail Maintenance Project, unless otherwise agreed to in advance by the City in writing. Notwithstanding the above, the City shall apply and pay for necessary storm water permits.

C. Duluth BCH shall ensure that its staff members, agents and volunteers complete the Trail Maintenance Project in a professional and diligent manner and shall use its best efforts to

complete the Trail Maintenance Project in accordance with Trail Maintenance Project timelines and schedules.

XII. RECORDS RETENTION. Duluth BCH shall maintain all books, records, documents, and other evidence pertaining to this Agreement for six (6) years after termination or expiration of this Agreement for any reason.

XIII. GOVERNMENT DATA PRACTICES. All data collected, created, received, maintained or disseminated for any purpose by the parties because of this Agreement is governed by Minn. Stat. § 13.05, Subd. 11. Duluth BCH shall comply with Minn. Stat. § 13.05, Subd. 11. Duluth BCH agrees to hold the City, its officers, and employees harmless from any claims resulting from Duluth BCH failure to comply with this law.

XIV. WAIVER. The waiver by the City or Duluth BCH of any breach of any term, covenant, or condition of this Agreement shall not be deemed to be a waiver of any subsequent breach of same or any other term, covenant, or condition in this Agreement.

XV. SEVERABILITY. If any term or provision of this Agreement is declared by a court of competent jurisdiction to be illegal or in conflict with any law, then the validity of the remaining terms and provisions shall not be affected, and the rights and obligations of the parties shall be construed and enforced as if this Agreement did not contain the particular term or provision held to be invalid.

XVI. RECITALS INCORPORATED. The recitals at the beginning of this Agreement are true and correct and are incorporated into this Agreement by reference.

XVII. NO THIRD PARTY RIGHTS. This Agreement is to be construed and understood solely as an agreement between Duluth BCH and the City regarding the subject matter herein and shall not be deemed to create any rights in any other person or on any other matter. No person shall have the right to make a claim that they are a third party beneficiary of this Agreement or of any of the terms and conditions hereof, which may be waived at any time by mutual agreement between the parties.

XVIII. NOTICES. Notices provided pursuant to this Agreement shall be sufficient if sent by regular United States mail, postage prepaid, addressed to:

| | |
|------------------------------------|-----------------------------------|
| Duluth Back Country Horsemen of MN | City of Duluth |
| Attn: Deserae Hendrickson | Attn: Parks Manager |
| 2917 Lismore Road | 411 W. First Street, Ground Floor |
| Duluth, MN 55804 | Duluth, Minnesota 55802 |
| contact@duluthhorsetrails.org | (218) 730-4300 |

or to such other persons or addresses as the parties may designate to each other in writing from time to time.

XIX. INCIDENT REPORT. Duluth BCH shall promptly notify the City in writing of any incident of injury or loss or damage to the Trails or any staff members, volunteers or invitees occurring during the performance of the Trail Maintenance Project. Such written report shall be

in a form acceptable to the City's Claims Investigator and Adjuster and sent to the Manager. A copy of the City's form of Incident Report is attached as Exhibit C.

XX. COMPLIANCE WITH AGREEMENT. The right of Duluth BCH to use the Trails are subject to Duluth BCH's compliance with the undertakings, provisions, covenants, and conditions set forth in this Agreement.

XXI. APPLICABLE LAW. This Agreement, together with all of its paragraphs, terms, and provisions, is made in the State of Minnesota and shall be construed and interpreted in accordance with the laws of the State of Minnesota.

XXII. AMENDMENTS. All amendments to this Agreement shall be in writing and shall be executed in the same manner as this Agreement.

XXIII. AUTHORITY TO EXECUTE AGREEMENT. The parties represent to each other that the execution of this Agreement has been duly and fully authorized by their respective governing bodies or boards, that the individuals who executed this Agreement on their behalf are fully authorized to do so, and that this Agreement when thus executed by said individuals will constitute and be the binding obligation and agreement of the parties in accordance with the terms and conditions of this Agreement.

XXIV. COUNTERPARTS. This Agreement may be executed in two or more counterparts, each of which shall be deemed an original as against any party whose signature appears thereon, but all of which together shall constitute but one and the same instrument. Signatures to this Agreement transmitted by facsimile, by electronic mail in "portable document format" (".pdf"), or by any other electronic means which preserves the original graphic and pictorial appearance of the Agreement, shall have the same effect as physical delivery of the paper document bearing the original signature.

XXV. KEYS. The City's Properties and Facilities Manager or his or her designee (the "PFM Manager") shall be exclusively responsible for the design and designation of keying systems, lock changes, key fabrication and key distribution for any locks within the Trails. Duluth BCH shall comply with the City's Key Control Policy, a copy of which shall be provided to Duluth BCH, and is subject to unilateral change by the City during the Term.

Exhibit B



a chapter of



CONSTRUCTION SPECIFICATION

January 18, 2019

COGGS Project #: 01-2019

Duluth Traverse Trail System
2019 Club Bid

COGGS

Cyclists of Gitchee Gumee Shores
PO Box 161261
Duluth, MN 55815
United States

Table of Contents

1.0 CERTIFICATION5

SECTION 1: PROJECT DESCRIPTION AND SCOPE 6

1.1 GENERAL PROJECT DESCRIPTION 6

1.2 MOUNTAIN BIKE-SPECIFIC SINGLETRACK..... 6

1.3 PROJECT SCOPE 7

1.4 ADDITIONS AND DELETIONS 7

1.5 DISCREPANCIES 7

1.6 PROJECT LOCATION DESCRIPTIONS..... 7

SECTION 2: PROJECT DETAILS..... 8

2.1 QUARRY PARK CONNECTOR – PROJECT #18

2.2 BREWER PARK CONNECTOR – PROJECT #2.....8

2.3 ANTENNA FARM PHASE II DT SPINE – PROJECT #38

2.4 UMD DT SPINE SEGMENT – PROJECT #49

2.5 EAST LESTER RIVER TRAIL – PROJECT #59

SECTION 3: FINISHED TRAIL CONSTRUCTION AND MAINTENANCE GUIDELINES.....11

3.1 TRAIL DESIGN..... 11

3.2 BIKE-SPECIFIC TRAIL FLOW 11

3.3 TRAIL SPECIFICATIONS 11

3.4 EROSION AND SEDIMENTATION CONTROL 12

3.5 TRAIL CONSTRUCTION BEST PRACTICES 12

3.6 CORRIDOR CLEARING..... 12

3.7 DEBRIS 12

3.8 TREAD 12

3.9 TREES 13

3.10 ROCKS 13

3.11 WOODY MATERIAL..... 13

3.12 FALL ZONE CLEARING 13

3.13 BACKSLOPE..... 13

3.14 TRAIL, FINISHED CONDITION 14

3.15 SPOILS STABILIZATION..... 14

3.16 TURNS..... 14

3.17 BROLLERS (BERMED ROLLERS)..... 14

3.18 GRADE REVERSALS 15

3.19 ABOVE-GRADE EARTHEN STRUCTURES..... 15

3.20 WATER DIVERSIONS 15

3.21 INVASIVE SPECIES 15

3.22 FILTER STRIPS 15

3.23 ENVIRONMENTAL AND HISTORIC PRESERVATION 16

3.24 SIGNAGE AND WAYFINDING 16

3.25 MECHANIZED EQUIPMENT BEST PRACTICES..... 16

SECTION 4: UNIT DEFINITIONS AND DETAIL DRAWINGS17

4.1 TRAILS SPECIFICATIONS (TABLE 1) 17

4.2 TRAIL FLAGGING 17

4.3 TRAIL CONSTRUCTION (FIGURES 1 - 4)..... 18

4.4 TRAIL TYPES (FIGURE 4.1)..... 19

4.5 ARMORED TREAD/STONE PITCHING (FIGURE 5)..... 19

4.6 ARMORED TREAD/TURF BLOCK PAVERS (FIGURE 6) 20

4.7 ROLLING GRADE DIP (FIGURE 7) 20

4.8 TERRACE (FIGURE 8) 21

4.9 ROCK RETAINING WALL (FIGURE 9) 21

4.10 INSLOPED BERMED TURN (BERM) (FIGURE 10)..... 22

4.11 INSLOPED SWITCHBACK (SWITCHBERM) (FIGURE 11)..... 22

4.12 ROCK BENCH..... 23

4.13 TECHNICAL TRAIL FEATURES, BOARDWALKS, AND BRIDGE (FIGURE 12)..... 23

4.14 ROCK RIP-RAP..... 24

4.15 COIR ROLL (BIO LOG) INSTALLATION (FIGURE 13)..... 24

4.16 CAUSEWAY OR TURNPIKE TRAIL CONSTRUCTION (FIGURE 14) 25

4.17 TRAIL CLOSURE OR TRAIL OBLITERATION (FIGURE 15) 25

4.18 MAP POST INSTALLATION (FIGURE 16) 25

4.19 TRAIL CAPPING (FIGURE 17)..... 25

4.20 WOOD CRIB WALL RETAINING WALL (FIGURE 18) 26

4.21 ROCK ARMORED FORD (FIGURE 19)..... 26

4.22 CULVERTS..... 26

4.23 MODIFICATIONS..... 26

4.24 TABLES AND FIGURES..... 27

SECTION 5: CONTRACTOR QUALIFICATIONS, REQUIREMENTS AND RESPONSIBILITIES ... 43

5.1 PROFESSIONAL ASSOCIATION 43

5.2 MOUNTAIN BIKE-OPTIMIZED EXPERIENCE..... 43

5.3 INSURANCE..... 43

5.4 WORKMAN’S COMPENSATION..... 43

5.5 TOOLS..... 43

5.6 MECHANIZED EQUIPMENT BEST PRACTICES 43

5.7 BACKCOUNTRY PROTOCOL..... 44

5.8 PERSONAL PROTECTIVE EQUIPMENT..... 44

5.9 TIMETABLE 44

5.10 MEETINGS AND PROGRESS REVIEWS..... 44

5.11 WHAT CONTRACTOR PROVIDES 44

5.12 FOOD AND WATER 44

5.13 TOILET FACILITIES 45

5.14 PARKING..... 45

5.15 PUBLIC SAFETY 45

5.16 ENVIRONMENTAL FOOTPRINT 45

5.17 FEES FOR LICENSES, PERMITS, AND INSURANCE..... 45

5.18 EMPLOYEE/SUBCONTRACTOR CONDUCT..... 45

5.19 EMPLOYEE COMPETENCE 45

5.20 COMPLIANCE WITH MODERN PRACTICES 46

5.21 CONDITION OF MATERIALS AND EQUIPMENT..... 46

5.22 DISPOSAL OF MATERIALS AND SUPPLIES NOT APPROVED 46

5.23 DISPOSAL OF MATERIALS AND SUPPLIES NOT USED..... 46

5.24 ACCESS CONTROL 46

5.25 USE OF PREMISES – STORAGE..... 46

5.26 TRAIL REHABILITATION..... 47

5.27 USE OF SUBCONTRACTORS..... 47

5.28 INDEMNITY..... 47

5.29 PROTECTION OF FINISHED CONSTRUCTION..... 47

SECTION 6: REGULATIONS AND STANDARDS48

6.1 JURISDICTIONAL REGULATION 48

6.2 DAVIS-BACON & PREVAILING WAGE..... 48

6.3 APPLICABLE LAWS AND COURTS 48

6.4 ANTI-DISCRIMINATION 48

6.5 ETHICS IN PUBLIC CONTRACTING..... 48

SECTION 7: TIMELINE AND SCHEDULE49

7.1 PROJECT TIMELINE 49

7.2 PRE-BID CONFERENCE AND SITE VISIT 49

7.3 DEADLINE FOR REQUESTS FOR CLARIFICATIONS/QUESTIONS..... 50

7.4 RESPONSES TO REQUESTS FOR CLARIFICATIONS DISTRIBUTED..... 50

7.5 BID SUBMISSION DEADLINE..... 50

7.6 ANTICIPATED AWARD ANNOUNCEMENT 50

7.7 CONTRACT AND INSURANCE CERTIFICATE 50

7.8 WORK COMPLETE 50

SECTION 8: BID SUBMISSION PACKAGE51

8.1 BID SUBMISSION..... 51

8.2 SUBMITTAL CHECKLIST 51

SECTION 9: BASIS FOR AWARD, RIGHT OF REJECTION, AND CANCELLATION.....51

9.1 BASIS FOR AWARD 51

9.2 RIGHT OF REJECTION 51

9.3 QUALIFICATIONS AND EXPERIENCE..... 51

9.4 ADDITIONAL INFORMATION 52

9.5 ESTIMATED QUANTITIES..... 52

9.6 PARTIAL AWARD..... 52

9.7 RIGHT OF CANCELLATION..... 52

SECTION 10: COMMUNICATION AND REQUEST FOR CLARIFICATIONS53

10.1 POINT OF CONTACT 53

10.2 REQUEST FOR CLARIFICATIONS..... 53

10.3 CONTACT PROTOCOL..... 53

10.4 EMAIL COMMUNICATION 53

SECTION 11: FINAL INSPECTION, SUBTANTIAL COMPLETION, RETAINAGE, WARRANTY AND PAYMENT.....54

1.0 Certification

DATE: JANUARY 18, 2019

I HEREBY CERTIFY THAT THIS PLAN, SPECIFICATION OR REPORT WAS PREPARED BY ME OR UNDER MY DIRECT SUPERVISION AND THAT I AM A DULY REGISTERED LANDSCAPE ARCHITECT UNDER THE LAWS OF THE STATE OF MINNESOTA.

NAME

REGISTRATION NUMBER

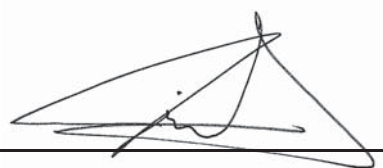

JAMES M. SHOBERG, LANDSCAPE ARCHITECT

45577

SECTION 1: PROJECT DESCRIPTION AND SCOPE

1.1 General Project Description

The Cyclists of Gitchee Gumees Shores (herein referred to as “COGGS”) is seeking a contractor to provide an experienced trail crew to construct approximately ±3.0 miles of new mountain bike-specific natural surface singletrack trails on public lands in Duluth, MN. This is Phase 8 of a multi-year project that seeks to create upwards of 100 miles of singletrack. Duluth, MN is situated at the western most point of the Great Lakes on the north shore of Lake Superior.

The surrounding city park lands demand a high standard-of-care during construction activities due to steep topography, exposed bedrock and proximity to trout streams. Blasting is not an anticipated component of this bid however rock breaking will be encountered in this build. For more information about soil conditions visit the National Cooperative Soil Survey at <http://websoilsurvey.sc.egov.usda.gov/>

The contractor will be responsible for implementing and maintaining the Stormwater Pollution Prevention Plan (SWPPP) supplied by the COGGS.

The trail alignment corridor has been flagged by COGGS with approval from the City of Duluth (herein referred to as the “City”). The flag line represents the center line of a 50 foot wide corridor. As part of this project the contractor is responsible for final field alignment and design and must remain within 25 feet on either side of the corridor flag line. It is also the responsibility of the contractor to remain 50’ away from private property where possible as depicted in the plan. If there is a need to go outside the corridor or get closer than 50’ to a private property the contractor must receive written Club approval.

The area is front country, with many areas of mobile phone coverage, and is located less than one hour from emergency medical service.

1.2 Mountain Bike-Specific Singletrack

It cannot be more strongly emphasized that this project is for purpose-built mountain bike natural surface singletrack trail. Desired characteristics include: cambered trail surfaces, insloped turns, aggressively rolling terrain, incorporation of native rock features, and seamless transitions between trail types. Trail features and flow should *progress* as a user gets deeper into the system; larger, tighter, more narrow examples of similar elements moving from “green” (easier) to “blue” (more difficult) to “black” (most difficult) areas. Along segments intended for more skilled trail users, optional lines available only to more-skilled riders are highly desirable and encouraged.

In partnership with the Club, the contractor will be expected to maximize the potential of the landscape hosting the trail corridors. Creativity is encouraged. A portfolio of previous mountain bike-focused work will be heavily weighted in the selection process.

1.3 Project Scope

To satisfy funding requirements for the project, the work outlined in this document shall be completed by November 1st 2019.

Overall, the project's scope of work includes up to approximately ±3.0 gross miles of new trail construction including: berms, switchberms, technical trail feature (TTF) boardwalks, rock armoring and bridges. The Storm Water Pollution Prevention Plan (SWPPP) outlines general construction information and best management practices (BMPs) as they apply to the stormwater pollution prevention as it relates to trail project construction activities.

This project is funded by private funding from the local mountain bike club Cyclist of Gitchee Gumees Shores (COGGS).

1.4 Additions and Deletions

No extras or additional work outside of the construction documents will be allowed or paid for unless such extras or additional work are ordered in writing by the Club, and the price fixed and agreed upon before such work is performed. The Club will not accept any overruns nor will it pay any quantities beyond those specified.

The Club shall have the right, without invalidating the contract, to make additions to or deductions from the work defined in this document, and in case such deductions or additions are made, an equitable adjustment of the addition to or deduction in cost shall be made between the Club and the contractor, but must be agreed to in writing.

1.5 Discrepancies

Should the contractor discover discrepancies in this document, the plans or specification, the matter shall at once be brought to the attention of the Club, and the discrepancies corrected before proceeding further. Bid tabulation sheets quantities take precedence over quantity discrepancies in the specifications or plans.

1.6 Project Location Descriptions

There are many potential locations for staging and trail access. This project goes through the heart of Duluth with many nearby road and parking areas. Contractor is to provide a request in writing for staging and laydown areas prior to the start of construction.

SECTION 2: PROJECT DETAILS

Below are brief project descriptions and important project details.

2.1 Quarry Park Connector – Project #1

Starting in Quarry Park this segment is about ½ mile following the eastern rim of the quarry starting in the quarry infield and terminating at Skyline Parkway. The lower portion follows an existing walking trail that will need to be rebuilt and slopes reduced to make it more beginner for bikes. We want the contractor to build this trail as a two-way green flow trail as beginner as possible wherever possible. Overall the running slope is expected to exceed what we consider beginner and should be the only spec that exceeds beginner specifications.

The terrain is mostly moderate slopes with portions of outcropped bedrock. There are significant piles of overburden that will be built through and can be utilized as a borrow source in this segment. Wetland flanks the eastern edge while a private parcel sitting in the middle of the site that must be avoided. Property lines of this parcel will be flagged in the field to ensure avoidance.

Once above the quarry the terrain mellows out a little bit and is a mix of rock bands, jumbled rock piles, and loamy sandy soils. The tree canopy is thin and there is patchy underbrush.

2.2 Brewer Park Connector – Project #2

Once above Skyline Parkway the terrain changes drastically. The first portion that parallels Skyline Parkway is dominated by high cliff bands, talus and scree slopes, large boulders and bedrock with some limited soils dispersed in between. The second portion that makes the connection up the hill is still very rocky but is not as steep and has more soils present to work with.

Overall this segment is about ½ mile in length and begins on Skyline Parkway terminating up the hill in Brewer Park tying into an existing trail. The portion that parallels Skyline Parkway is dominated by very steep side slopes and some moderate slopes. This build is to be constructed as a narrow advanced black diamond free-ride trail segment that is two-way but with a preferred direction of downhill. As an alternate we would like to have pricing to build this as a blue intermediate flow trail.

The contractor will work with the club to identify rock climbing/bouldering areas that are to be avoided by the trail. They will be marked in the field at the time of construction. Vegetation is sporadic with segments of brush and some larger trees.

2.3 Antenna Farm Phase II DT Spine – Project #3

From east to west this segment is approximately ½ mile in length and connects Hilltop Park to Enger Park through a residential area. It is to be constructed as a two-way green level flow trail as much as possible and as the terrain allows. At any point if the contractor does not feel beginner trail is possible they must receive written approval from the Owner prior to construction of that element.

This segments begins in Hilltop Park on an existing trail before dumping out onto a gravel road. Through this stretch expect to find soils dominated by sandy loam and gravel based on nearby projects. The underbrush is dense through this segment before it dumps out to a gravel road.

The central segment is the next portion that stays entirely within a 66 foot wide unplatted right-of-way. Property lines will be marked in the field to ensure construction stays on public lands. There is a lot of outcropped bedrock through this portion including two large bellies of bedrock. The easterly most belly can be avoided but the central belly is unavoidable. We have included details for an optional wood crib wall construction technique that the contractor may use if they deem necessary to traverse this bedrock segment. Through the bedrock areas there is little to no vegetation and through the forested segment the vegetation is at times a dense thicket of underbrush dominated by invasives.

The westerly most segment jumps back into Enger Park and follows a low cliff band with a mix of soils and boulders. The vegetation is mostly open with some sparse underbrush before it connects back into the existing trail system.

2.4 UMD DT Spine Segment – Project #4

This segment begins at Arrowhead Road and is approximately 1.0 mile in total length before it terminates on Brainerd Avenue. It is to be constructed as a two-way beginner green level flow trail. Half of this segment is within the boundary of the university Bagley Nature Center while the other half utilizes a narrow stretch of undeveloped land between a neighborhood and university parking lots and apartment buildings. Property lines will be marked in this segment as there is not much room to stray outside of the flagged corridor.

Based on site observations and nearby similar projects expect to find a mix of loamy sandy and gravelly soils. There is a segment thought the Bagley Nature area that has a high content of larger rock with a short portion of exposed bedrock. The site is densely forested throughout with variable underbrush conditions ranging from thick underbrush to open areas with little to no underbrush.

There are special considerations that must be abided by in this segment. Some vegetation will be marked in the field with tags that indicate the plant specimen is part of a research project. These specimens must not be disturbed and avoided during construction. There is a patch of invasive knotweed. The soil in the area of the knotweed cannot be disturbed or transported and a boardwalk must be built over the patch.

2.5 East Lester River Trail – Project #5

Approximately ½ mile in length this project is located at the eastern most terminus of the Duluth Traverse System in Lester Park on the north end of Duluth. It is to be constructed as a two-way beginner green level flow trail. As an alternate we would like to have pricing to build this as a blue intermediate traditional singletrack trail. The trail itself begins at the parking lot just off Lester River Road as an existing limestone path. No work needs to be done to this limestone portion of the trail.

Your flag line begins where the limestone path ends a few hundred yards up river. From that point there is an existing informal footpath about 12"-18" in width. It is in very poor condition and was not purpose built nor does it follow sustainability best practices. We will not be using this corridor and rerouting much of the alignment as all new trail.

This site's terrain is dominated by moderate side slopes with several areas of extreme slopes pinched between the river and the road with no room to vary from the flag line. There are also several cliff band areas where the trail will cross on the bare bedrock or pass very closely to or just above. Based on past construction projects in the area expect to encounter soils dominated by heavy red clays with little to no stone or rock present.

Exhibit B

Trail Specifications Matrix Duluth Traverse Trail System Version: 1.7 (01/18/19)

| Label | Working title | Difficulty Rating | Symbol ¹ | Use | Directional | Feature Frequency ² | Constructed Tread Width ^{3, 4} | Ave Trail Grade per 100' ⁵ | Max Trail Grade: climbing ⁵ | Max Trail Grade: descending ⁵ | Min Turn Radius | Max Turnpad Grade ⁷ | Max Berm/Turn Camber ⁸ | Corridor Width (4' above tread) | Corridor Height Minimum | Boardwalk Width | Exposure (without railing) ⁹ | Unavoidable Obstacles | Avoidable Obstacles (over 50% of tread or less) | Rollable Feature Height (Jumps, berms, etc.) | Roughness (surface texture) ⁹ | Tread and trail features | Notes |
|---------|-----------------------------------------------------------------------|-------------------|---------------------|-------------------|-------------|--------------------------------|-----------------------------------------|---------------------------------------|----------------------------------------|------------------------------------------|-----------------|--------------------------------|-----------------------------------|---------------------------------|-------------------------|-----------------|-----------------------------------------|----------------------------|-------------------------------------------------|----------------------------------------------|------------------------------------------|------------------------------------------------------------------------------------------------------------------------------------------|--------------------------------------------------------------------------------------------------------------------------------------------------------------------------------------------|
| Spec 1 | Green Singletrack (Traditional bike optimized shared-use singletrack) | Easier | Green Circle | bike, foot | Two-Way | Low | 48" | 5% | 20% | 20% | 10' | 10% | 15% | 48"-72" | 10'-12' | 48" | less than 36" | less than 2" | less than 6" | 12" | low | Firm trail surface. May include rock armored section. | |
| Spec 2 | Blue Singletrack (Traditional bike-optimized singletrack) | More Difficult | Blue Square | bike, foot | Two-Way | Medium | 36" | 7% | 25% | 50% (armored over 25%) | 8' | 15% | 30% | 36"-72" | 8'-12' | 36" | less than 48" | less than 8" | less than 24" | 24" | med | Modest rough tread is expected. May include steps and terraces. | May include features similar to those on easier "Bump and Pump" or "Jump" trails. |
| Spec 3 | Black Singletrack (Traditional technical singletrack) | Most Difficult | Black Diamond | bike, foot | Preferred | High | 18" | 10% | 50% (armored over 25%) | 100% (armored over 25%) | 6' | 15% | 50% | 36"-48" | 8'-12' | 24" | no limit | less than 18" | less than 48" | 36" | high, some very high | Significant unavoidable obstacles are expected. May include steps, stairs, rock gardens, loose rock, and significantly exposed sections. | Seek out rocky ridges. Selective machine work to create very organic appearing rock strewn tread. Most rock and tread work is aimed at sustainability rather than ease of passage. Trials- |
| Spec 4 | Green Flow Trail (Bump Pump) Singletrack | Easier | Green Circle | bike, foot | Preferred | High | 48" | 3-5% | 20% | 30% (armor as function of flow) | 15' | 10% | 30% | 48"-72" | 8'-10' | 48" | less than 36" | less than 2" | less than 6" | 12" | low | Firm trail surface. Rollers and berms. May include rock surfaced sections. | The Lester River Trail in Lester Park, Enger Park Trail and the Upper Cathedral Trail in Mission Creek are examples of this spectrum |
| Spec 5 | Blue Flow Trail (Bump Pump) Singletrack | More Difficult | Blue Square | bike, foot | Preferred | High | 36" | 7-10% | 30% | 100% (armor as function of flow) | 10' | 15% | 50% | 36"-72" | 10'-12' | 36" | less than 60" | less than 2" | less than 24" | 24" | low | Firm trail surface. Rollers, roller doubles, berms predominate. May include significant armored sections. | Demonstration trail at Spirit Mtn is an example of the upper end of this spectrum. |
| Spec 6 | Black Flow Trail (Bump Pump) Singletrack | Most Difficult | Black Diamond | bike | One-Way | High | 36" | 10-12% | n/a | 150% (armor as function of flow) | 7' | 25% | 150% | 36"-72" | 10'-12' | 36" | less than 120" | less than 8" | less than 48" | 36" | med | Firm trail surface. Rollers, roller doubles, berms predominate. May also include steps, stairs, rock gardens and exposed | |
| Spec 7 | Green Jump | Easier | Green Circle | bike | One-Way | Medium | 48"+ | 3-5% | n/a | 30% (armor as function of flow) | 20' | 10% | 150% | 48"-72" | 10'-12' | 60" | less than 36" | less than 2" | less than 6" | 18" | low | Smooth continuously cambered trail surface. Easily rollable jumps. | A green jump trail could fit within a stacked-loop system. Blue and Black are likely best done at a resort. |
| Spec 8 | Blue Jump | More Difficult | Orange Pill, medium | bike | One-Way | Low | 48"+ | 7-10% | n/a | 100% (armor as function of flow) | 15' | 15% | ∞% | 48"-72" | 12'-15' | 48" | less than 60" | less than 2" | less than 24" | 30" | low | Smooth continuously cambered trail surface. May include significant armored sections. More complex jump | Complete berms, plan on extreme drainage solutions - sumps + culverts. |
| Spec 9 | Black Jump | Most Difficult | Orange Pill, large | bike | One-Way | Low | 48"+ | 10-12% | n/a | 150% (armor as function of flow) | 15' | 25% | ∞% | 48"-72" | 12'-15' | 48" | less than 120" | less than 8" | less than 48" | 48" | med | Firm trail surface. May include rock surfaced sections. Some jumps may not be rollable. | Complete berms, plan on extreme drainage solutions - sumps + culverts. |
| Spec 10 | Green Gravity | Easier | Orange Pill, small | bike | One-way | Medium | 48" | 7-10% | n/a | 100% (armor as function of flow) | 20' | 15% | 150% | 48"-72" | 12' | 60" | less than 36" | less than 18" | less than 24" | 18" | high | Entry level downhill course. Will include rocks, steps, and terraces. Drops will be rollable. | For all DH types, potentially only at Spirit Mtn. |
| Spec 11 | Blue Gravity | More Difficult | Orange Pill, medium | bike | One-way | Medium | 36" | 10-15% | n/a | ∞% (mandatory drops) | 15' | 25% | ∞% | 36"-72" | 12' | 48" | less than 60" | less than 48" | n/a | 30" | very high | Intermediate level downhill course. Mandatory drops. Will include significant steps, stairs, rock gardens and exposed | |
| Spec 12 | Black Gravity | Most Difficult | Orange Pill, large | bike | One-way | High | 24" | 15-20% | n/a | ∞% (mandatory drops) | 15' | 25% | ∞% | 36"-72" | 12' | 48" | less than 120" | less than 72" | n/a | 48" | very high | Advanced level downhill course. Significant mandatory drops. Will include extreme terrain that has a high penalty | |
| Spec 13 | Gateway trail | Easiest | White Circle | bike, foot, horse | Two-Way | low | 48"+ | 3-5% | 10% | 15% | 12' | | 10% | | 10'-12' | 60" | | | | | | | Very front-country, likely connected to a recreation park. Typically under a mile. |
| Spec 14 | Accessible trail | Easiest | | bike, foot, horse | Two-Way | none | 36" min | 0-5% | 8.3% | 8.3% | 5' dia space | | | | | | 30" | less than or equal to 1/4" | none | | low, surface must be firm and stable | Full tread with obstacles, where possible, should be separated by a minimum of 48" | ADA, ABA, AASTHO spec trail. |
| Spec 15 | Adaptive trail | Varies | | bike, foot | Two-Way | varies | | | | | | | | | | | | | | | | | ADA, ABA, AASTHO spec trail. |

Footnotes...

1. Orange Pill Symbol assumes trails inside controlled-access facilities, like a bike park or resort.
2. Feature Frequency is averaged over long distances. Per 100': "low" = 2-3 features, "med" = 3-5 features, "high" = 5-10 features.
3. Constructed tread width may narrow over short distances to 50% of spec. Examples include rock or tree gateways.
4. Tread width also applies to bridges and boardwalks. Check with local regulations for overriding guidelines on width or any other requirements (height restrictions, railings, etc.).
- 5 & 6. Max grades climbing and descending refer to extremely short segments. 10 feet or less.
7. Turnpad grade measures the rise/fall across the turnpads at the base of any incline.
8. Max camber is measured at the top of the incline. More advanced berms will go to "vertical".
9. Roughness attempts to capture average tread coarseness. Tread area with obstacles: "low" = less than 5%, "med" = less than 20%, "high" = over 20%, "very high" = over 50%.

General Notes

Sustainable trails guidelines provide the foundation for all design + construction decisions ("half rule", frequent grade reversals, max grades function of soils + use, etc.). All trails should have a minimum grade and camber (in/outslope) of 3% to ensure a well-drained tread.

SECTION 3: FINISHED TRAIL CONSTRUCTION AND MAINTENANCE GUIDELINES

3.1 Trail Design

Design of any new segments or reroutes must be guided by the sustainable trail principles published by accepted resources such as the current editions of the *Trail Solutions*; *IMBA's Guide to Building Sweet Singletrack*; *Managing Mountain Biking*; *IMBA's Guide to Providing Great Riding*; the USDA's *Trail Construction and Maintenance Notebook* and the *Minnesota Department of Natural Resources' Trail Planning, Design, and Development Guidelines*.

3.2 Bike-Specific Trail Flow

All trails constructed as part of this project shall be natural surface singletrack trail that is purpose-built for mountain bicyclists, sometimes described as *flow trails*. A subset of the larger family of rolling contour trails, flow trails share the following basic characteristics:

- *Synergy with the landscape*: Making the most of what the natural terrain provides by using the trail to explore the topography and features (rocks, trees, waterways) present. Some describe a trail with good flow as one that has been revealed in the landscape, not so much as constructed.
- *Opposition to user forces*: Flow trails maximize the efficiencies afforded by using a bicycle, and are designed to counteract forces that direct a user off the trail. Bermed turns and cambered tread surfaces, for example, promote traction, safety, sustainability, and enjoyment.
- *Conservation of momentum*: The ideal trail avoids “flow killers” such as sharp turns, incongruent features, and disjointed climbs and descents. Instead, it utilizes undulations and cambered turns to reward smooth, deliberate riding and maximizes forward motion. A flow trail encourages a better understanding of the bicyclist/bicycle interface, allowing riders to reach that unique sensation of floating through the landscape.
- *Leading the user forward*: A sense of discovery, combined with a design that maximizes a rider's forward momentum, helps to draw the user forward. The trail is never repetitive or predictable, nor is it “awkward”, with variety and innovation combining to create an intuitive feel.

3.3 Trail Specifications

The trail system is composed of a number of loops and segments design, constructed, and maintained to a defined trail specification as outlined in the “Trail Specification Matrix”. Making use of a range of different specifications results in a *complete* trail system when creating the overall trail system masterplan. This method appeals to a wider range of users, with different fitness, technical proficiency, or preferred modality. It is important that individual segments and loop maintain consistent specification over their length to ensure visitors have the experience they expect.

A project-specific “Trail Specification Matrix” is included along with the definition of project units.

3.4 Erosion and Sedimentation Control

Management of erosion and sediment on this project is defined in the provided Storm Water Pollution Prevention Plan (SWPPP). All construction activities must conform to the requirements of the SWPPP. Any inconsistencies created by the construction specifications do not excuse the contractor violating the procedures and requirements laid out in the SWPPP.

No excavation or fill is permitted in wetlands. Wetlands will not be marked in the field. It is the responsibility of the contractor to consult with Club prior to doing any work within suspected wetlands areas.

3.5 Trail Construction Best Practices

To satisfy erosion and sediment control requirements, trail must be finished as the project advances. Any roughed-in corridors not being worked for 24 hours must be completed trail to reduce the exposure of non-compacted tread to moisture. Any segments requiring delayed finishing must be approved in advance by the Club. Any disturbed areas not part of active tread must be stabilized within 24 hours of not being worked with native duff from within the trail corridor or erosion control blanket and seed as defined in the SWPPP. Wood chips created from the slash as a result of the trail corridor clearing are an acceptable mulch alternative to weed free straw.

3.6 Corridor Clearing

Corridor clearing shall be confined to within four (4) feet of trail and backslope edges. Specific values are identified in the “Trail Specifications Matrix” included with the definition of project units.

3.7 Debris

Cut and scatter all branches, roots and brush to a maximum height of eighteen inches (18”) above grade. No debris shall be left within ten feet (10’) of trail. Butt-ends of any sawed limbs must face away from trail. Cut brush and slash must be disposed of in an upland location and must be kept out of streams, gullies, swales, low areas, and suspected wetlands.

3.8 Tread

All tread should be constructed as full bench whenever possible. If fill is required, it should be supported by a stone retaining wall or approved equal.

Specific tread widths are based on their difficulty rating and are specified in the “Trail Specifications Matrix” included along with the definition of project units. Narrower gateways through natural obstacles (trees, rock outcrops) are encouraged. Tread widths in areas of dynamic flow, jump landings, and insloped turns, for example, may be wider to accommodate the full range of riding experiences. Significant deviations from these examples require prior written approval from the Club.

3.9 Trees

These trails are to be built with minimal impact to the over story trees and the surrounding forest. Only brush and small trees should be removed from the trail corridor. Trees larger than 6" DBH require permission from the Club before they are removed. Removal of healthy trees approaching this size should be avoided and only done when there is not a better option. Dead, dying, and rotted trees can be removed to open up the trail corridor as necessary for grading or if they present a clear hazard to trail builders or trail users.

3.10 Rocks

Maximum size rock material to be left in trail is based on the difficulty rating and defined in the "Trail Specification Matrix". Specific values are enumerated in the "Trail Specifications Matrix" including definition of project units.

Rocks that are unearthed during grading shall be used as anchors or built into trail features and stabilized not more than five feet (5') away from the trail-edge. It is not permitted to allow rocks to roll down the slope. The trail will be routed around or over rocks and fractured stones that cannot be moved with the approved equipment.

These requirements do not apply in areas where rocky tread is integral to the flow goals of a specific segment (e.g., technical rock gardens, slabs that provide jump or "kicker" opportunities). Exceptions also apply in boulder fields or where only a portion of the tread is obstructed. All rock embedded in the trail surface should be stable. When used in structures, care will be taken to match rock to the immediate surroundings; grain patterns, lichen growth, etc. Excess tool marks on rocks shall be avoided as much as possible. Non-native rock may not be imported into a work area without approval of the Club.

3.11 Woody Material

Woody material such as stumps, logs, roots and brush shall be removed from the trail tread. No stumps less than twelve inches (12") in diameter shall be left within four feet (4') of the trail tread. Wood chips created from the slash as a result of the trail corridor clearing may be dispersed at a depth no greater than 4" and are an acceptable mulch alternative to weed free straw. Contractor may ONLY chip woody material that was created as a result of the corridor clearing.

3.12 Fall Zone Clearing

Areas adjacent to dynamic trail segments where visitors have a greater potential to exit the immediate trail corridor will be cleared of impact focusers; butt-end branches, stumps, and rocks under six-inch (6") diameter.

3.13 Backslope

Backslope of trail should be graded to three-to-one (3:1) slope or until it matches the existing slope. In areas where the backslope has the potential to become part of the active tread it must be finished to trail tread specifications.

3.14 Trail, Finished Condition

Hand finish and grading of trail tread, backslope, down slope spoils, and drainage features shall leave a surface that matches the texture of the surrounding forest floor while enabling water to drain off the trail.

3.15 Spoils Stabilization

All excavated materials not used in the trail tread or other constructed trail features must be stabilized within 24 hours of not being worked. Spoils should be distributed in a thin layer adjacent to the trail tread not more than 4" in depth. Care should be taken to avoid placing spoils in drainages, swales or wetlands. When possible, spoils must be mulched with native materials to discourage erosion while native seed stocks reestablish. In areas without adequate native duff mulch, wood chip mulch may be substituted along with the approved seed mix per the attached seed mix exhibit. In certain circumstances, installation of formal erosion control measures may be required.

3.16 Turns

A turn is defined as a change-of-direction that turns more than 90 degrees across the local landscape. All turns are to be bike optimized insloped turns. Turns that exceed 12" of insloped tread height above the surrounding landscape are defined as constructed features. The bid worksheet identifies constructed turns as either insloped switchbacks also known as switchberms or an insloped bermed turn or berm. If conditions warrant, a traditional rolling crown switchback may be substituted for a switchberm with prior written approval from the Club. Insloped turns that are less than 12" in height above the surrounding landscape are included in the contractors unit bid price for all trail construction types.

Insloped and off camber tread necessary for trail flow that are less than a 90 degree change in direction are not turns and are included in the contractors unit bid price for all trail construction types.

Acceptable values for turn radius, camber and turnpad grade are identified in the trail specifications. Turns should be constructed to have good flow for wheeled trail users. All turns must include an entrance and exit rolling grade dip. Building through uneven grades, flat areas and undulations local to a specific turn is included in the contractor's unit bid price.

Turns that are less than 12" in insloped height are included in the contractors unit bid price for all trail types. Berms and switchberms that are over 12" in height are quantified in "Bid Worksheet B".

If it is determined in the field that additional turns or an alternative type of turn is necessary than what was specified in the plans, the contractor must request written approval from the Club prior to construction.

See 5.9 Berm (figure 10) and 5.10 Switchberm (figure 11) for unit turn types.

3.17 Brollers (Bermed Rollers)

A broller is defined as tilted tread surface that is insloped or off camber in excess of the standard tread out slope of 5%. Brollers do not result in a change of direction across the landscape and do not cross the fall line. Brollers are included in the unit bid price for all trail construction types and are not considered berms or turns.

3.18 Grade Reversals

A designed grade reversal or constructed rolling grade dip should occur at least every one hundred feet (100') and preferably more frequently. Any grade reversal must be strongly anchored with a significant landscape feature, boulder, or large tree or trees, to discourage short cutting.

In mountain bike-specific trails, grade reversals also double as flow elements, such as rollers, jumps, and pump/rhythm sections. In this context grade reversal shape, size, and placement should reflect the specifications for its location within the system. Specific details will be determined by the contractor in partnership with the Club.

3.19 Above-Grade Earthen Structures

Any portion of trail rising above the grade of its surroundings must be composed of mineral soil. If soil is scarce, a rock core may be used so long as it provides less than fifty percent (50%) of the total volume of the structure. Use of organic materials, duff, woody materials, etc., is absolutely prohibited.

Fill structures must have a fill slope of at least the angle of repose of the local soil. A retaining wall may be substituted for a fill slope with permission of the Club. Fill structures must be completely stabilized and compacted in no greater than six-inch (6") lifts. Acceptable techniques include track-packing or compaction via a dedicated tamping unit. Hand tamping is not acceptable. Raw soil faces that do not become tread must be mulched and seeded in the same fashion as spoils and satisfy the terms of the project SWPPP.

Examples of above-grade earthen structures include aggressive grade reversals ("rollers", "brollers", "jumps"), berms, switchberms and turn pads on insloped switchbacks.

3.20 Water Diversions

All tread should be out-sloped at five percent (5%). When not possible or desirable due to purpose-built in-sloping, resource concerns, or obstructions, water can be directed down the trail for up to fifty feet (50') before a water diversion location.

3.21 Invasive Species

To reduce the spread of invasive plant species all hand tools and mechanized equipment should be free of soil, seeds, and clean of any dirt and mud when entering a project site. When transferring materials between distinct locations within town or within the project site all tools and equipment must again be cleaned to discourage transport of invasives to the local landscape.

Equipment is subject to inspection at the start and will be requested to be removed and replaced if found to have soils or seeds present from a sources not native to the location. This will be done at the expense to the contractor.

3.22 Filter Strips

Filter strips are vegetated areas downslope of the trail corridor intended to treat sheet flows coming off the tread. Filter strips function by slowing down flow velocities, filtering out sediments, and providing an opportunity for infiltration into the underlying

soils. Properly mulched spoils may be designated as part of the filter strip. Filter strips shall not be used as regular travel-ways for equipment and materials. Areas with inadequate filter strip capacity above waterways may require installation of formal erosion control measures to satisfy erosion and sediment control plan requirements.

At all times, filter strip characteristics must satisfy the terms of the project Stormwater Pollution Prevention Plan (SWPPP).

3.23 Environmental and Historic Preservation

The corridors identified in the provided design have been vetted through an assessment process to ensure they respect sensitive environmental and historic areas. The construction shall avoid any disruption or dislocation of sensitive cultural resources found on the site unless expressly authorized in writing by the Club. Any known sensitive cultural areas will be communicated to the contractor in writing before construction begins. In the event that previously unidentified historical artifacts are found during the construction process, trail construction must be immediately suspended in that area until it can be evaluated and a determination made on how to proceed. The Club will need to make final determination on how to proceed around sensitive cultural resources after consulting with appropriate archeologist personnel. The trail may be rerouted around the sensitive area or special accommodations may be made such as boardwalk. The decision on how to proceed will depend on the type and sensitivity of the resource and the distance separating it from the planned trail.

3.24 Signage and Wayfinding

Installation of the map post is the responsibility of the contractor. The map and content itself and other signage is the responsibility of the Club and its partners. Signage and its installation will comply with all the requirements of the authorized governing unit. Construction documents, (figure 16) and maps will identify the signage requirements, locations, frequency, and physical design plus materials standards.

3.25 Mechanized Equipment Best Practices

All track marks will be raked smooth. Affected area will be finished to have a *nature shape*, e.g., spoils piles rounded, smoothed and cleared of significant brush, blade edges blended. A spill kit suitable for five gallons of fluid will be onsite and within 500 feet of mechanized equipment whenever equipment is being operated. Scarring of trees is to be avoided. If scarring occurs contractor is responsible to paint with colors that match the color and pattern of the damaged tree to prevent infection or further degradation of the tree.

Machine service and fueling is not permitted within 500 feet of a wetland or drainage. Machine access is restricted to the trail corridor. Separate access routes may only be created and used with prior written permission of the Club. Any approved access route must be retired and reclaimed back to its original pre-existing condition upon project completion.

SECTION 4: UNIT DEFINITIONS AND DETAIL DRAWINGS

Any accompanying figures are for illustrative purposes only and do not relieve contractor of the need to satisfy written requirements. All units may not be used in all projects. Additional units may be required. In this case, the Club will establish their definition via a change order process and the contractor must request in writing additional units if the amount is not sufficient in the bid document prior to construction.

4.1 Trails Specifications (table 1)

A “Trail Specifications Matrix” provides the foundation for the possible trail styles and a starting point for their defining characteristics. Contractor should always start here, whether composing their bid or designing/constructing trail elements. The Club understands that all trail, and especially bike-specific trail, is an art form strongly driven by local conditions and anticipates a collaborative effort between all parties involved.

Note that all types fit within the sustainable trail guidelines framework. While short specific grades may exceed typical suggested maximums, armoring is suggested in these cases. It is not acceptable to sacrifice “the half rule” or eliminate grade reversals to meet experience driven goals. When creating trails at these upper limits grade reversals are more important than ever.

A high-level summary of the various styles detailed in the matrix:

- *Traditional* – Typical shared-use natural surface singletrack as described in the standard trail texts. May include bike-specific elements, like in-sloped turns, berms, rollers, rollers, and jumps.
- *Bump and Pump* – Natural surface singletrack strongly influenced by pump tracks. Distinguishing feature is the high frequency of roller features. Proper shaping and spacing of rollers is critical, both to increase their utility as a method of propulsion and to match the intended speed and flow style of the segment. All turns are insloped. Tread surface is smoother than average. More difficult Bump and Pump segments may add smaller technical features and tread texture.
- *Jump* – A natural surface trail more focused on jump opportunities. Similar to Bump and Pump but with longer features less frequently placed. Tread is wider than average in recognition of the dynamic riding style likely on these segments. Corridor clearing limits are larger as well for similar reasons. Most Jump segments are directional.
- *Gravity* – An extremely technical downhill-specific trail. More difficult Gravity segments include mandatory drops in the tread. These segments may include structures to manufacture the desired experience when natural terrain is lacking. May include elements of Bump and Pump or Jump. Gravity trails are directional.

4.2 Trail Flagging

In this project, the centerline of a 50' wide trail corridor has been flagged by COGGS. The plans and specifications are based on this trail corridor. Final trail design is the responsibility of the Contractor within this corridor.

Corridor is marked with blue hanging drop flags. Final trail design should be at least fifty feet (50') from property boundaries unless otherwise authorized by the Club or identified in the plans.

Contractor shall mark with flagging tape all trees over six inches (6") DBH that are to be removed. Final determination on removal lies with the Club.

The trail should have a grade reversal a minimum of every one-hundred feet (100'). Trail should follow a rolling contour alignment and abide by the Half Rule. Grades must match the trail type defined by the "Trail Specification Matrix" for a specific segment.

4.3 Trail Construction (figures 1 - 4)

Trail construction unit costs are a combination of trail specification and landscape type. For each project, the specification is constant. But as the landscape changes, different construction units apply, matching the local terrain. Trail construction unit types A, B, and C are identified in the plan set and on the bid worksheets.

Measurement and payment for trail construction is based on landscape averages as depicted in the plan set. Grading through localized uneven grades, flat areas and undulations is included in the contractor's unit bid price for all trail unit construction types.

Creation of typical trail features as enumerated in the specifications (ex. Rollers and Brollers) are included in the trail construction units.

Each linear foot unit shall satisfy the enumerated guidelines for the specification associated with the specific segment. Trail width guidelines apply to active tread only; backslope and any fill slopes are not included. Tread variance will satisfy the guidelines for its location in the system. Note the global design attempts to match trail specifications to the landscape most suited for that type. In local landscapes where there is a mismatch, the contractor will be expected to modify the area to match the trail specification. An example is creating an easier "green" style trail through a locally rocky area. However, in this specific set of projects we are allowing "blue" construction through the rocky areas.

The trail corridor shall be cleared of all woody plants less than four inches (4") DBH. The extent of corridor clearing will meet the requirements for the specific trail type. Any stumps resulting from the clearing should be excavated and removed. Any woody debris not used in trail closure should be removed from sight of the trail or arranged to blend into the landscape.

Limb trimming will be done to open up the trail corridor as defined in specification for the specific segment. Limb trimming and pruning shall be completed using approved trimming techniques that comply with the guidelines for tree care operations from the American National Standards Institute (ANSI) contained in the ANSI A300 Pruning Standards and ANSI Z133.1-2000.

The trail tread shall consist of packed earth or rock. Any stumps and/or roots should be excavated and removed from the trail tread. Backslope dimensions are derived from surrounding area such that they satisfy the earlier stated three-to-one (3:1) definition. Any stumps and/or roots in the backslope should be flush-cut. In areas where the backslope has the potential to become part of the active tread (ex. naturally formed in-slopes or berms) it must be finished to trail tread specifications.

The trail should contain frequent grade reversals. To encourage self-cleaning the grade of the drains at the bottom of the grade reversals must be at least fifteen percent (15%) and typically not greater than twenty-five percent (25%). If the drain grade exceeds twenty-five percent (25%) then installing Rock Rip-Rap (see Section 5 – Rock

Rip-Rap) may be requested by the Club in the bottom of the drain to prevent head-cutting. If grade reversals result in a fill slope, these slopes and the associated feature(s) will be finished to satisfy the above-grade earthen structure guidelines. Contractor is expected to create frequent grade reversal regardless of the local landscape, this is included in low sideslope Type A trail construction. This may require localized topography modification, borrow pits and raised tread when building through landscapes with low slope angles.

Any downslope spoils must be distributed such that no berm is present. When distributing, care shall be taken to match the local terrain. Spoils must be stabilized within 24 hours of not being worked with a covering of forest duff. In areas with insufficient duff, sterile wood chips may be substituted for forest materials. Excess soil shall not be distributed into drainages, wetlands or adjacent to streams. Refer to the SWPPP for further details.

If borrow pits are created in the course of trail construction they will be finished to satisfy the requirements of the trail and its surroundings: slopes graded to the local angle of repose, stumps and roots trimmed, spoils stabilized and covered with forest duff. Borrow pit wall must be broken down to blend into the surrounding natural landscape slopes.

For billing purposes, trail construction is measured along the centerline of the tread.

4.4 Trail Types (figure 4.1)

Trail types are broken into three categories:

- Type "A" (Low Sideslope Trail) 3%-15% Sideslope
- Type "B" (Medium Sideslope Trail) 16%-60% Sideslope
- Type "C" (High Sideslope Trail) 61%+ Sideslope

Measurement and payment for trail construction types is based on the slope averages found in the field.

Grading through low spots, flatter areas, earthen piles, landslides, miscellaneous debris and fallen woody material is included in the contractor's unit bid price for each trail construction type. Builder is expected to create frequent grade reversals regardless of the local landscape. This may require localized topography modification including but not limited to raised tread, borrow pits and sumps when building through landscape with low slope angles such as "Type A Trail".

Contractor cannot invoice for both trail construction and constructed features of a given linear foot of trail.

4.5 Armored Tread/Stone Pitching (figure 5)

Width of armored tread should be at least 1.5 times the width of the local trail specification to permit users to find their line as the trail matures, and at least two (2) times in areas where more variation is likely (e.g., jump landings, insloped turns).

Stone pitching must extend at least ten inches (10") deep with a minimum of two-thirds (2/3) of the rock buried below the surface of the surrounding grade. Stones should be stable and aligned perpendicular to the direction of travel. Each end of a pitched section shall be supported by larger "bookend" stones embedded in the ground. Stones used for armoring should be two inches (2") to twenty-four inches (24") thick and

twelve inches (12”) to forty-eight inches (48”) wide. Voids shall be filled with compacted native soil, crushed rock, and/or crusher fines. Additional guide stones may be necessary along the edges of the trail if the final surface of the trail appears more rugged than the adjacent landscape.

For billing purposes, armoring is measured along the centerline of the tread. This unit includes the construction of the trail as well as armoring. Contractor cannot invoice for both trail construction and armoring of a given linear foot of trail.

4.6 Armored Tread/Turf Block Pavers (figure 6)

Turf block pavers are an alternate armoring technique to stone pitching where it is difficult to source appropriate native stone. As turf block pavers allow a more predictable tread surface, they are particularly appealing for “green”-style trails or for flow elements where excessive tread variance is not desired (e.g., high-speed insloped turns, some constructed jump elements).

Width of armored tread should be at least 1.5 times the width of the local trail specification to permit users to find their line as the trail matures, and at least two (2) times in areas where more variation is likely (e.g., jump landings, insloped turns). Turf blocks pavers must be installed as directed by manufacturer’s recommendations. Final installation should be nominally at-grade with the surrounding landscape. Individual paver blocks should be completely supported to reduce the chance of breakage. Height variance and joint spacing should both be less than one-half inch (0.5”). Blocks should be laid in a pattern to minimize joint lines. Paver voids are filled with local materials compacted to reduce settling.

For billing purposes, armoring is measured along the centerline of the tread. This unit includes the construction of the trail as well as armoring. Contractor cannot invoice for both trail construction and armoring of a given linear foot of trail.

4.7 Rolling Grade Dip (figure 7)

A rolling grade dip is a drainage feature added to existing trail. The minimum length of the drain portion shall be six feet (6’) and the rise must be at least ten feet (10’) long; the height differential between the bottom of the dip and the top of rise shall be approximately twelve inches (12”) to twenty-four inches (24”). The sides of rise must have a fill slope of at least two-to-one (2:1) or the angle of repose of the local soil, whichever is greater.

To encourage self-cleaning the grade of the drains at the bottom of the grade reversals must be at least fifteen percent (15%) and typically not greater than twenty-five percent (25%). If the drain grade exceeds twenty-five percent (25%) then installing Rock Rip-Rap (see Section 5 – Rock Rip-Rap) in the bottom of the drain to prevent head-cutting may be requested by the Club. If grade reversals result in a fill slope, these slopes and the associated feature(s) will be finished to satisfy the above-grade earthen structure guidelines.

Rolling grade dips must be sited at least thirty feet (30’) uphill from significant turns in order to reduce the effects of unweighting on higher speed users. Exceptions on these dimensions and requirements may be made on a site-by-site basis to accommodate terrain constraints. In certain locations the Club may determine that

smaller structures reinforced with large rocks that fit the character of the trail may be an acceptable substitute.

A rolling grade dip is billed as a “whole” unit.

4.8 Terrace (figure 8)

A terrace is a combination of landing, drain, retaining wall, and step useful for creating sustainable shared-use trail in steeper corridors than would be supported by the natural surface tread alone. Steps are used to accelerate the climb/descent while the use of landings between risers allows continued use by bicycles and equestrians. Terraces may be incorporated in new trail construction or applied as a corrective maintenance measure.

Step risers should be constructed out of stone; rot-resistant wood may be substituted with the approval of the Club. Maximum riser height is determined from the step height requirements of the trail segment. The riser shall be battered in the direction of uphill travel. A riser may be assembled from multiple stones with the understanding it must withstand the dynamic loading of climbing and descending users.

The landing must have a minimum length of at least 1.5 times the stride or wheelbase of the longest users. Each landing must contain a drain to the downhill side; it is not acceptable for a landing to drain over its riser. Drain differential must be at least six inches (6”). The fill required to create the landing is included in this unit.

The downhill edge of the landing must be supported by a retaining wall of stone; rot resistant wood may be substituted with the approval of the Club. The landing’s retaining wall must satisfy all the requirements of a stand-alone wall (see Section 5 – Rock Retaining Wall).

A terrace is billed per riser. For example, the figure shows parts of three (3) terraces

4.9 Rock Retaining Wall (figure 9)

A rock Crib Wall or Rock Retaining Wall is defined as a more than one row of stones stacked on top of each other greater than 12” in height specifically designed to hold back soils and raise the tread to meet variations in the running grade of the trail tread. A single row of stones placed at the downslope of a tread in order to create a full bench are not considered a retaining/crib wall and are included in the contractors unit price for that specific trail construction type.

The bidding unit of a rock retaining wall is square-feet, calculated from the exposed vertical face, Square Face Foot (SQ FF). Rock retaining walls should be stable and battered (inclined back into the slope) a minimum of fifteen percent (15%) from vertical. All walls should have rubble backfill of at least six inches (6”) in depth behind the wall to allow for drainage and to prevent damage from frost heaves. The base of the wall should be placed on firm compacted mineral soil or rock outcroppings. Any small stones used to “chink” larger stones in place should be placed in the back of the wall. The top of the wall shall not be counted in the width of the trail tread. The top layer of stones shall be installed in a manner to avoid being accidentally dislodged by trail users.

Deadmen (stones that extend from the wall into the slope) should be used to ensure integrity. There should be one deadman for every five square face foot (5 SQ FF) of wall.

4.10 Insloped Bermed Turn (Berm) (figure 10)

A berm is defined as an insloped change-of-direction that turns more than 90 degrees across the local landscape *not requiring* the trail to cross the fall line and is over 12” in height above the surrounding landscape. Trail tread that uses an existing embankment to change direction is also not a berm and is included in all trail construction unit types.

Acceptable values for berm radius, camber and turnpad grade are identified in the “Trail Specifications Matrix”. Berm radii should be consistent.

Fill structure for a berm will comply with composition, compaction, and fill slope requirements of an above-grade earthen structure.

For billing purposes, a berm is measured along the centerline of the tread by the linear foot at the point where the berm is over 12” in height above the bypass trail grade. This unit includes the construction of the bypass trail as well as the berm. Contractor cannot invoice for both trail construction and creating a berm over a given linear foot of trail. Locations and lengths of berms are identified in the plans.

4.11 Insloped Switchback (Switchberm) (figure 11)

A switchberm is defined as an insloped change-of-direction that turns more than 90 degrees across the local landscape *requiring* the trail to cross the fall line and is over 12” in height above the surrounding landscape. The switchberm unit includes any walls, armoring, setup berm, and drainage features associated with the structure as well as the trail itself.

Switchberm units are broken into three different units based on the sideslope of the surrounding terrain: Type “A” for low sideslopes, Type “B” for medium sideslopes and Type “C” for high sideslopes.

Each switchberm or insloped switchback requires a grade reversal or rolling grade dip before and after; these shall not be counted as separate units for payment purposes. The dips for these drainage features should be a minimum of six feet (6’) long. To encourage self-cleaning the grade of the drains at the bottom of the reversal/dip must be at least fifteen percent (15%) and typically not greater than twenty-five percent (25%). If the drain grade exceeds twenty-five percent (25%) then installing Rock Rip-Rap (see Section 5 – Rock Rip-Rap) in the bottom of the drain to prevent head-cutting may be requested by the Club. The uphill dip should be sited to minimize unweighting effects for higher speed users.

All switchberms or insloped switchbacks will be created with an insloped turnpad. Specifications for radius and cross slopes across the turn are defined in the “Trail Specifications Matrix” for the particular trail segment. Turning radii should be consistent. Turns with a running grade of twenty percent (20%) or greater in the apex should have a rock armored drain two feet (2’) wide following the inside of the turn. Interior of legs shall be anchored by and filled with large rocks and/or woody debris to discourage shortcutting.

If required, the fill structure for the turnpad will comply with composition, compaction, and fill slope requirements of an above-grade earthen structure. Club may require that a retaining wall be employed in place of a fill slope. Any retaining structures will be constructed of stone and comply with all rock retaining wall specifications. If multiple switchbacks are required, they will be sited to minimize “stacking”. Stacking is defined

as the placement of subsequent turns and associated drains and support structures in close proximity to the same fall line area of a hill or slope.

A switchberm is billed as a “whole” unit. The unit starts at the initiation of the uphill and completion of the downhill drainage structures. Quantities, type, and locations are identified in the plans.

4.12 Rock Bench

Rock bench construction is defined as trail tread construction through areas of exposed bedrock and slick rock where rock breaking and or blasting may be required. The rock found in Duluth is weathered at the surface and often fractured lending rock breaking a proven technique to get through these difficult areas. It is not anticipated that any blasting will be required as part of this project.

In order to save on construction costs construction through rocky areas a variation from the Green Trail specification to the Blue Traditional Trail Specification as enumerated in the “Trail specification Matrix” is allowed. However, effort must be made to keep the construction as close to the Green Specification as possible.

Rock bench construction is billed per the linear foot. If a bedrock area does not require any rock breaking or blasting to allow the passage of the trail no billable units will be applied to that portion of the trail.

4.13 Technical Trail Features, Boardwalks, and Bridge (figure 12)

Contractor is to provide typical shop drawings of the actual boardwalks planned to be constructed for approval by the Club for a given segment of TTF boardwalk based on the engineered construction documents found in the plan set.

TTFs and Boardwalks should have a playful and organic appearance to better match the natural environment. Recommendations include curved structures instead of straight lines or angles and trail deck that pitch, yaw, and vary in width.

Specific guidelines for TTFs and boardwalks are included in the plan set supplied for the project.

General guidelines include the following. Wooden structures must be designed and constructed with the assistance of an experienced professional. Acceptable materials for the riding/deck surface must be rough cut lumber and includes: Cedar, Tamarack, Black Locust, and Treated Pine. All other lumber used in the construction can be either rough cut or planed dimensional treated pine lumber. Treated lumber shall be treated in accordance with AWWA Standard C2/C9 with ACQ 0.4 LBS/CF Ret. And 0.6 LBS/CF Ret. for 6x6's and wood in contact with the ground. Unapproved treated lumber, creosote soaked railroad ties, or similar lumber cannot be used since these would introduce toxins into the natural environment.

All cuts and drilled holes shall be saturated with 2 coats of copper naphthenate in a 2% solution. Allow treatment to absorb into wood prior to applying second coat. Avoid applying treatment over water and be extra careful whenever applying this treatment over or near water to prevent contaminating the water. Follow the treatment manufacturer's recommendations.

Hardware shall be corrosion/rust resistant, such as triple dipped hot dip-hot dipped galvanized or stainless steel, intended for outdoor use, and matched to the material to insure long-term integrity. All hardware shall meet ASTM A307. All hardware that is hot

dipped galvanized shall meet ASTM A153. To maintain consistency though out the trail system all fastener heads shall be T25 hex heads. Nails are not an acceptable fastener and will be rejected.

Deck materials should be rough-cut or finished with a slip-prevention coating to maximize traction. Approaches and configuration of structures shall be adjusted to reduce the accumulation of organic material on deck surface. A fall zone sufficient to accommodate the likely trajectory of a trail user accidentally leaving the structure shall be cleared of all materials that could focus impact (e.g., stumps, sharp rocks, woody materials).

Pre-engineered TTFs are an acceptable alternative to custom construed wooden features. Deck material on pre-engineered TTF must match the acceptable deck materials as described in this specification section.

To reduce the amount of toxic chips introduced into the landscape, preparatory tasks (primary cutting and drilling, refinishing of cut edges of all treated lumber) shall occur offsite. At the project site, all final drilling, fitting, and retreating will be done in a "temporary workshop" area where a tarp or similar is used to capture chips and any spilled preservatives.

This unit includes design, materials, preparatory tasks, mobilizing materials into the project area, and installation.

For billing purposes, a boardwalk or bridge is measured along the centerline of the tread. This unit includes the construction of the trail as well as the boardwalk. Contractor cannot invoice for both trail construction and boardwalk of a given linear foot of trail.

4.14 Rock Rip-Rap

Rock Rip-Rap is a six inch (6') deep layer of placed stone intended to stabilize slopes with concentrated storm flow. Typically this technique will be used to protect drains of rolling grade dips and drainage channels below an armored crossing. Individual stones should be gabion-class or equivalent. Rock Rip-Rap is included in the contractors unit bid price for trail construction or constructed feature.

4.15 Coir Roll (Bio Log) Installation (figure 13)

Coir Rolls or Bio Logs are formal erosion control measures. They are installed in areas where the existing vegetative filter strip is inadequate to prevent sediment from reaching adjacent water courses. See project SWPPP for additional detail.

Rolls/Logs are placed parallel to trail and/or anticipated concentrated flows, set in a minor indentation excavated approximately two inches (2") deep. They are held in place with one inch-by-one inch (1"x1") or one inch-by-two inch (1"x2") wooden bio degradable stakes driven through the center of the roll/log at least six inches (6") into the ground, stopping about two inches (2") above the roll/log. Use five (5) stakes twenty inches (20") to twenty-four (24") long in the typical roll/log. Set the roll/log with foot-tamped backfill on the uphill side to prevent water from flowing underneath.

Erosion control prevention is billed on a per project basis as a lump sum.

4.16 Causeway or Turnpike Trail Construction (figure 14)

A causeway or turnpike is defined as an elevated trail tread utilizing mineral fill material confined by stable edge materials on both sides such as stone or rot resistant timber and is to be used when constructed through poorly drained areas. This application cannot be used in wetlands. Where suspected wetlands are present a boardwalk must be constructed to avoid disturbance.

A ditch can be dug parallel to and on both sides of the causeway to improve drainage. This variation is often called a turnpike. The material excavated from the ditches can be used to help fill the causeway if they are composed of mineral soil. The interior of the turnpike must be excavated down to mineral soil to create a firm and stable base for the fill material.

Causeway or turnpike trail tread construction is billed per the linear foot.

4.17 Trail Closure or Trail Obliteration (figure 15)

Compacted tread will be scarified to encourage regrowth of native seed stock. Small plants and other nearby growth will be transplanted into scarified treadway. Seed and mulch meeting the mix requirements of the SWPPP may be used in this application. Exposed soils will be covered with local leaf litter. Trail tread will be disguised with woody debris. If trail is incised, check dams will be placed at a minimum of every twenty feet (20') to capture sediment. If trail is actively eroding, grade reversals will be added to stem continued damage. Trail corridor will be erased via the placement of vertical debris. If length of trail to be closed is greater than one hundred (100) linear feet than vertical debris must extend a minimum of fifty feet (50') from each end or until visible sight line is diminished, whichever is greater.

For billing purposes, closure is measured along the centerline.

4.18 Map Post Installation (figure 16)

Install map post according to (figure 16). Treated lumber shall be treated in accordance with AWPA Standard C2/C9 with ACQ 0.4 LBS/CF Ret. And 0.6 LBS/CF Ret. for 4x4 map posts and wood in contact with the ground. Unapproved treated lumber, creosote soaked railroad ties, or similar lumber cannot be used since these would introduce toxins into the natural environment. Map post locations to be marked in the field by the Club.

4.19 Trail Capping (figure 17)

Trail capping is for those locations where the underlying native mineral soils do not support usage under normal trail conditions. Typical soils found in these locations include fat clays and water saturated soils not in wetlands. These locations are to be identified at the time of construction in the field by the contractor. Any zones that are to be capped must be quantified by the contractor and submitted to the Club in writing for approval prior to capping. For bidding purposes, trail capping is measured by the linear foot (LIN FT).

4.20 Wood Crib Wall Retaining Wall (figure 18)

In this application the Wood Crib Wall or Wood Retaining Wall is to be anchored to exposed smooth unfractured bedrock. Any fractured stone is to be chipped away until a smooth clean surface is exposed. The bottom timber shall be cut to meet the contour of the bedrock. The stacked timbers are to be anchored to the bedrock with steel rods and epoxy suitable for rock to wood exteriors must be used. See (figure 18) for specific construction details.

Treated lumber shall be treated in accordance with AWWA Standard C2/C9 with ACQ 0.4 LBS/CF Ret. And 0.6 LBS/CF Ret. for 4x4 map posts and wood in contact with the ground. Unapproved treated lumber, creosote soaked railroad ties, or similar lumber cannot be used since these would introduce toxins into the natural environment.

This detail is to be only used when stone or other natural materials are unavailable or likely to fail. This construction technique is specifically designed to hold back soils and raise the low end of the tread to meet variations in the cross slope of the trail tread. This bid item includes the mineral backfill used on the side of the wall that is retaining soils to create the trail tread at a 3% to 5% cross slope.

For bidding purposes, wood retaining wall is bid by the linear foot (LIN FT), and is measured from the exposed top beam by the wall.

4.21 Rock Armored Ford (figure 19)

Grade reversals will be created in the trail tread prior to the crossing on each bank. Maximum grade on each approach is thirty percent (30%) for a maximum distance of fifty feet (50'). Armored tread surface will extend through the stream and up the banks until a grade of less than ten percent (10%) can be achieved. The armored tread will be flush with stream bottom to discourage failures from cavitation. Armoring will extend downstream one-half (1/2) the required maximum tread width of trail tread to discourage headcutting. For bidding purposes Rock Armored Fords are measured by the unit.

4.22 Culverts

Pipe culverts may be corrugated plastic pipe (CPP) only. Remove organics in ditch bottom for culvert to sit on solid ground. Place culvert ends flush with the ditch bottom. Place rocks around the culvert's upstream end to armor the bank against erosion.

Install culvert according to manufacturer's specifications, especially those relating to ground cover to prevent collapsing. Generally, the greater of ("half the pipe diameter" or "12 inches") is the minimum cover to ensure that a culvert will not collapse under load or float up over time and become exposed.

4.23 Modifications

Modifications to the specifications may be allowed, however, they must be made to the Club in writing.

4.24 Tables And Figures

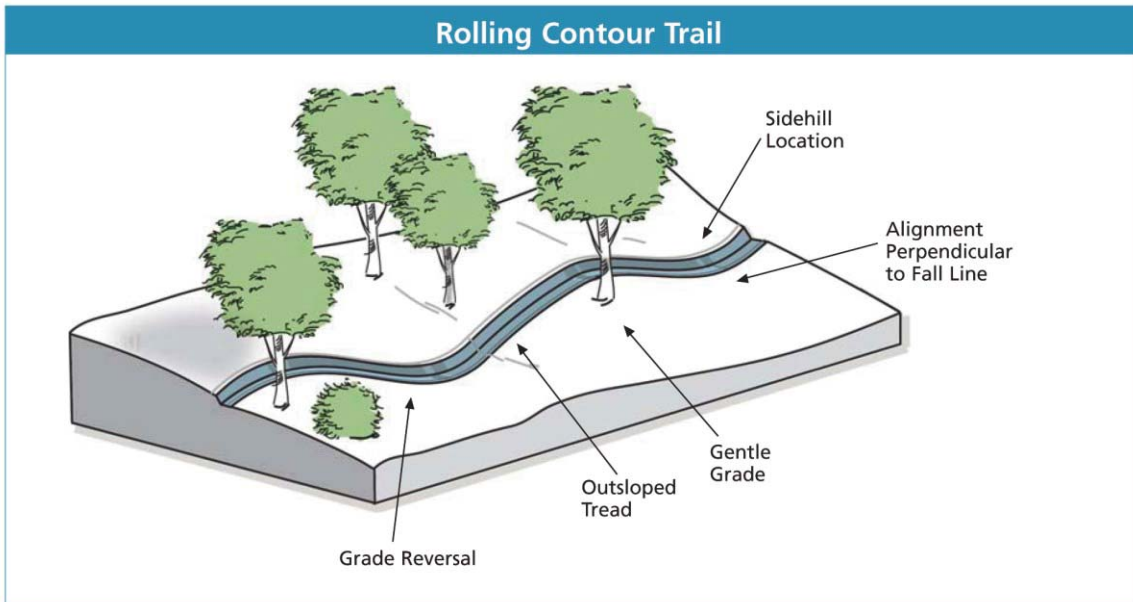

Figure 1: Rolling Contour Trail

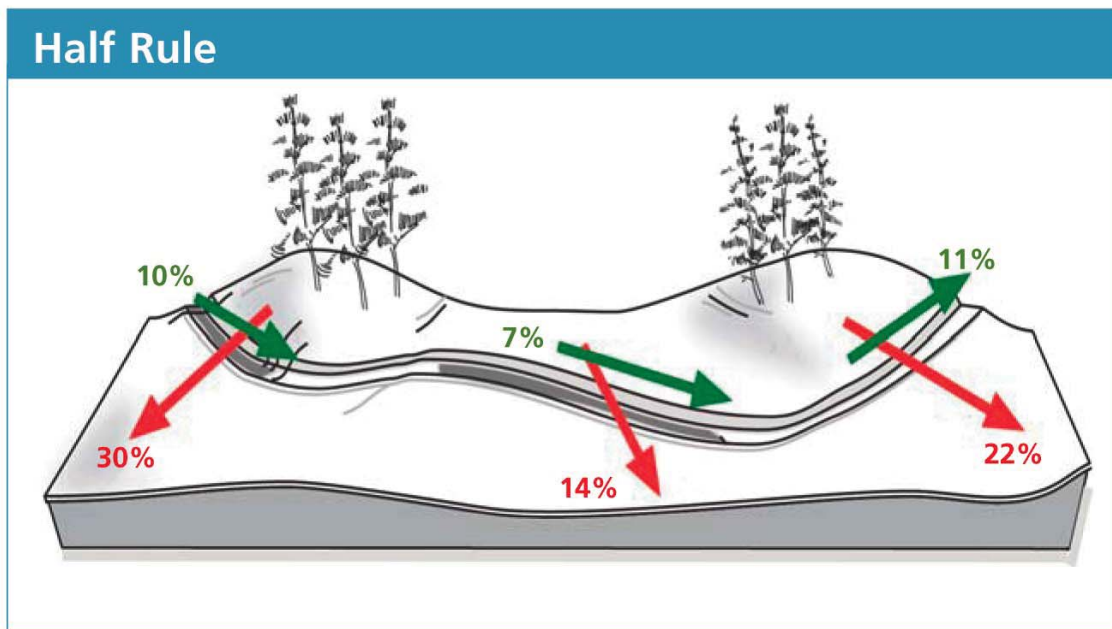

Figure 2: Illustration of "The Half Rule"

Full Bench Trail

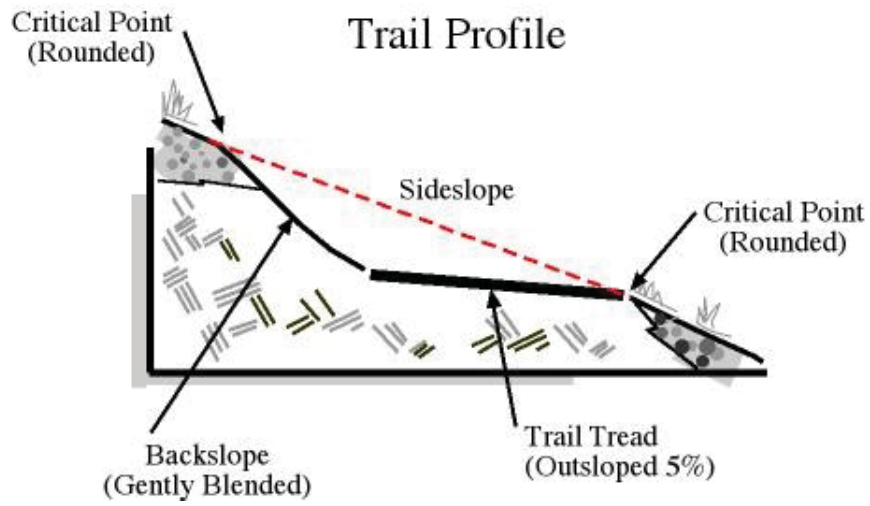
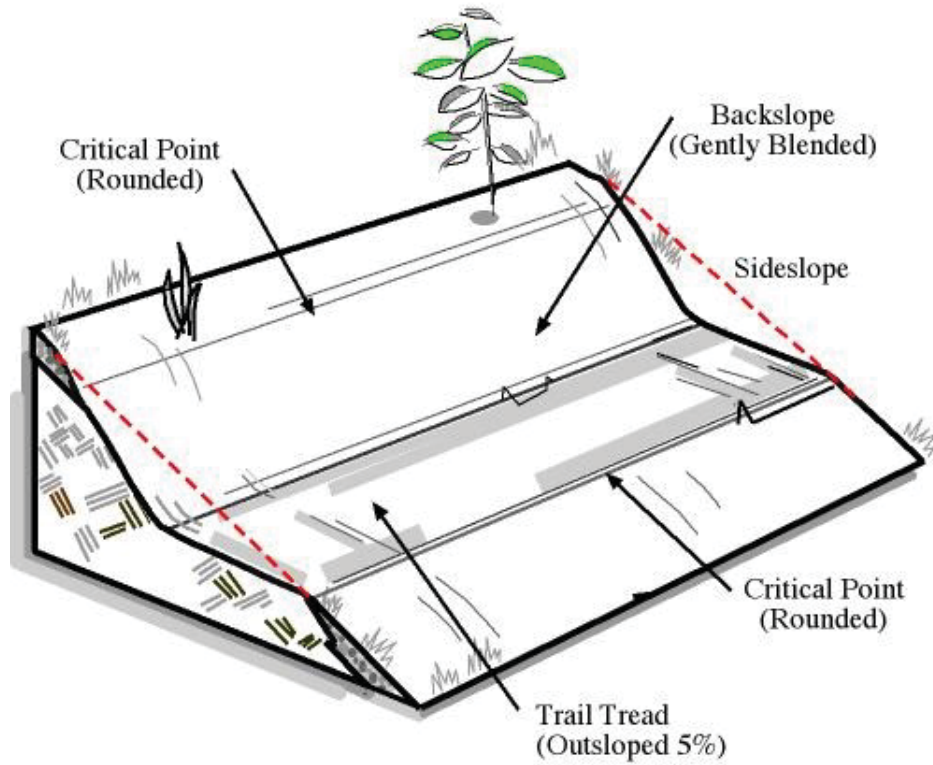

Figure 3: Full Bench Trail

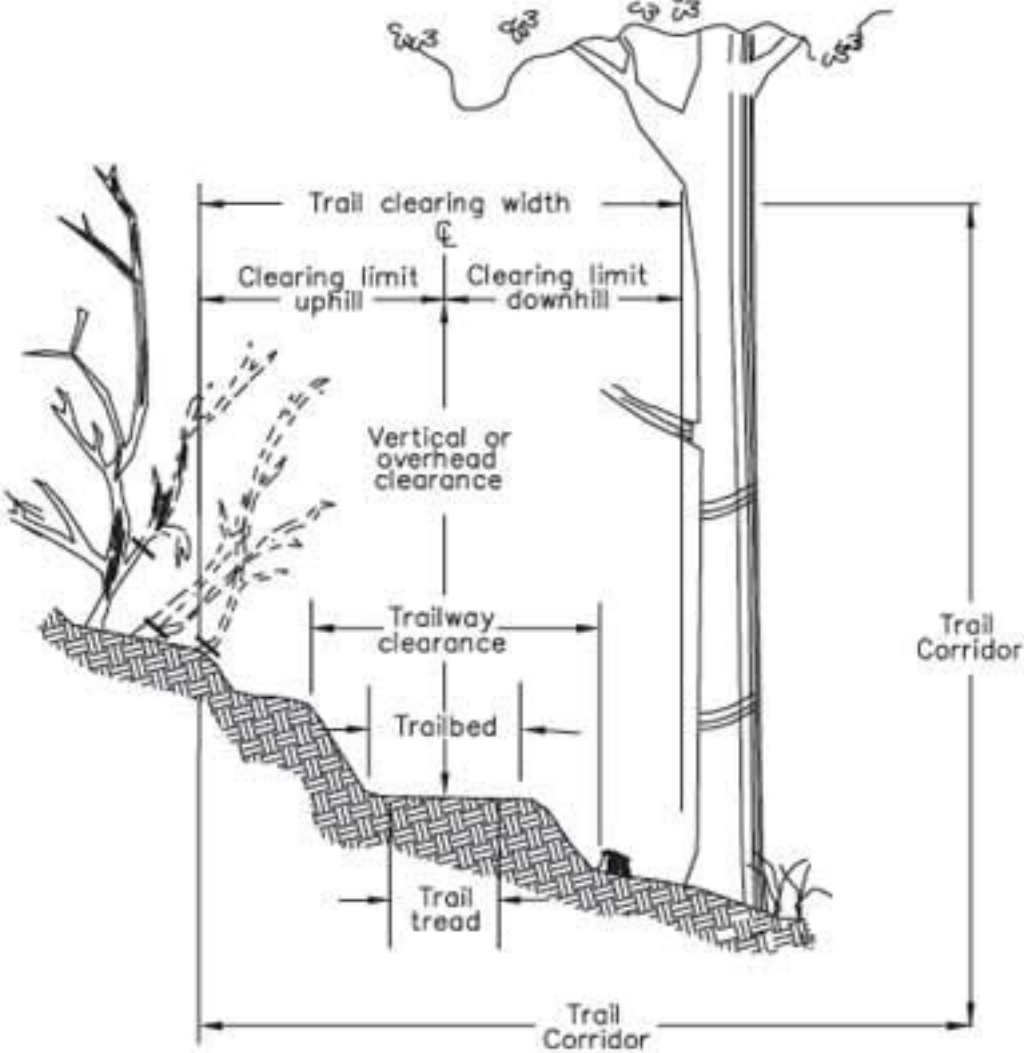
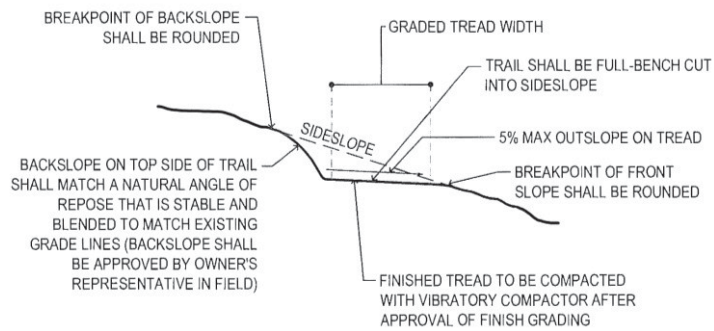
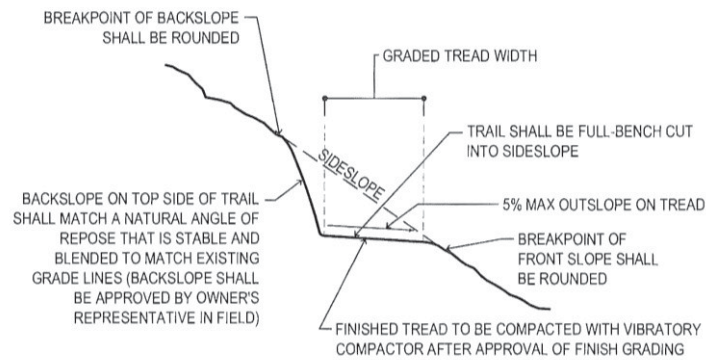

Figure 4: Clearing limits



Type A Type "A" (Low Sideslope Trail) 3%-15% Sideslope



Type "B" (Medium Sideslope Trail) 16%-60% Sideslope

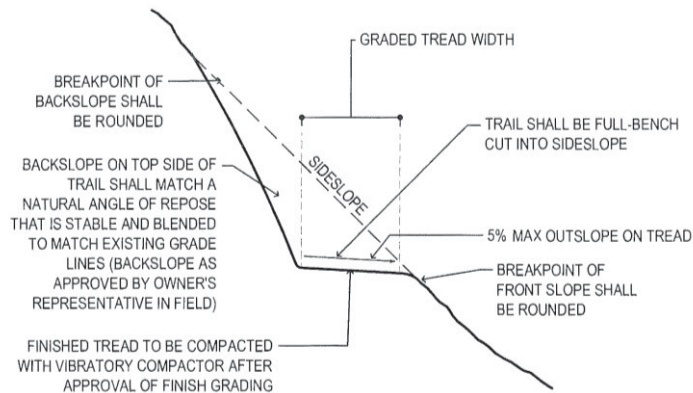

Type "C" (High Sideslope Trail Trail) 61%+ Sideslope

Figure 4.1: Trail Types

Stone Pitching

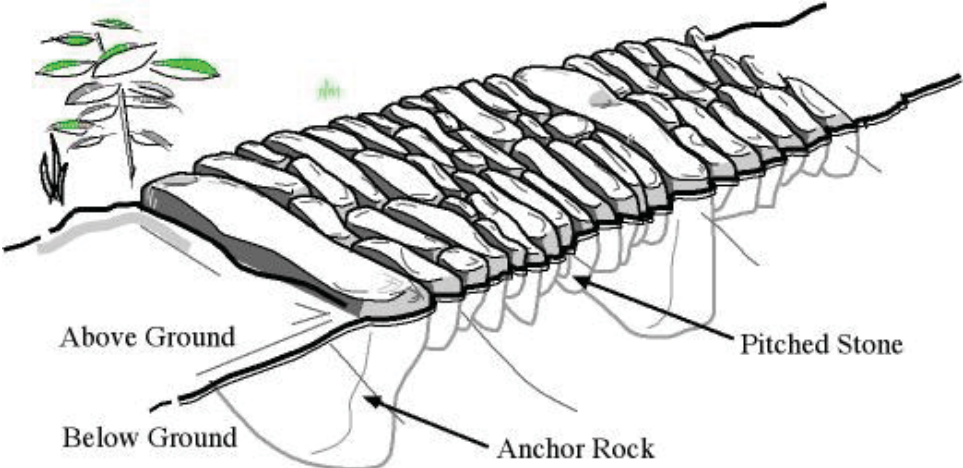

Figure 5: Tread Rock Armoring

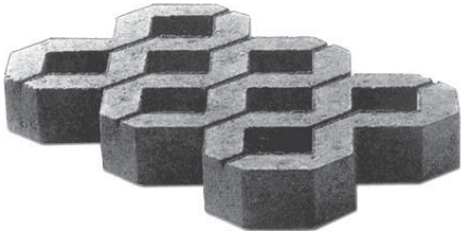

Figure 6: Turf Block Pavers

Rolling Grade Dip

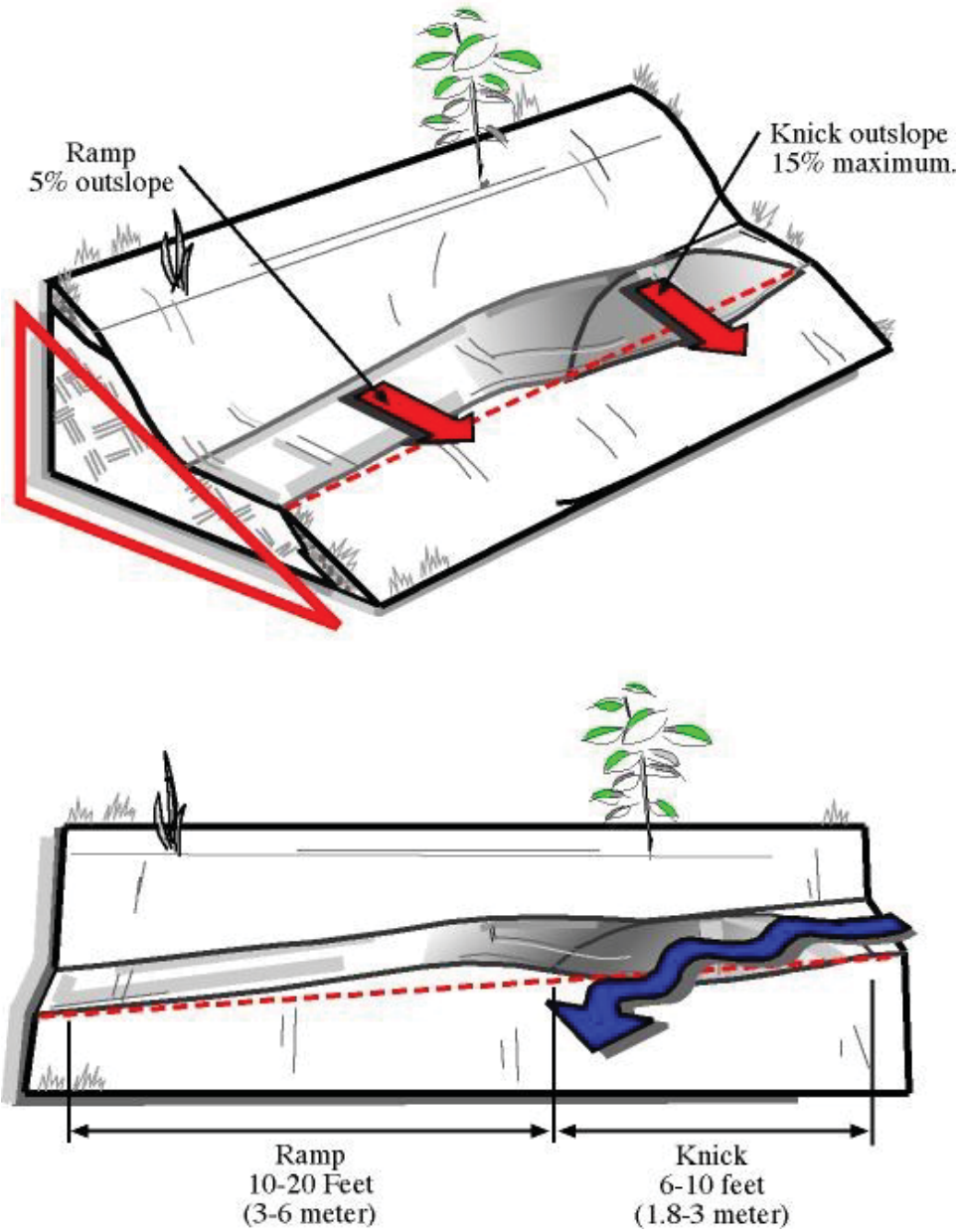

Figure 7: Rolling Grade Dip

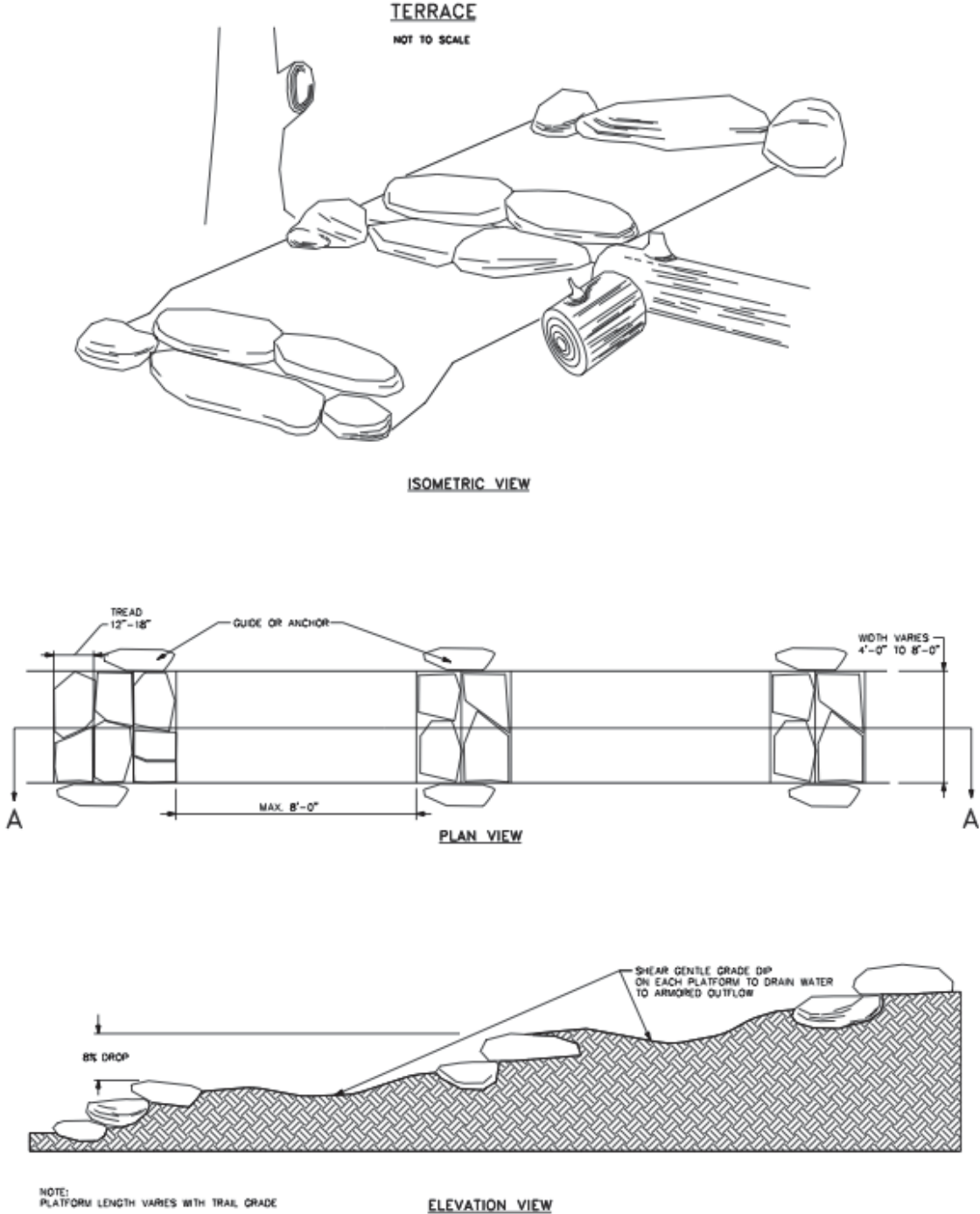

Figure 8: Terrace

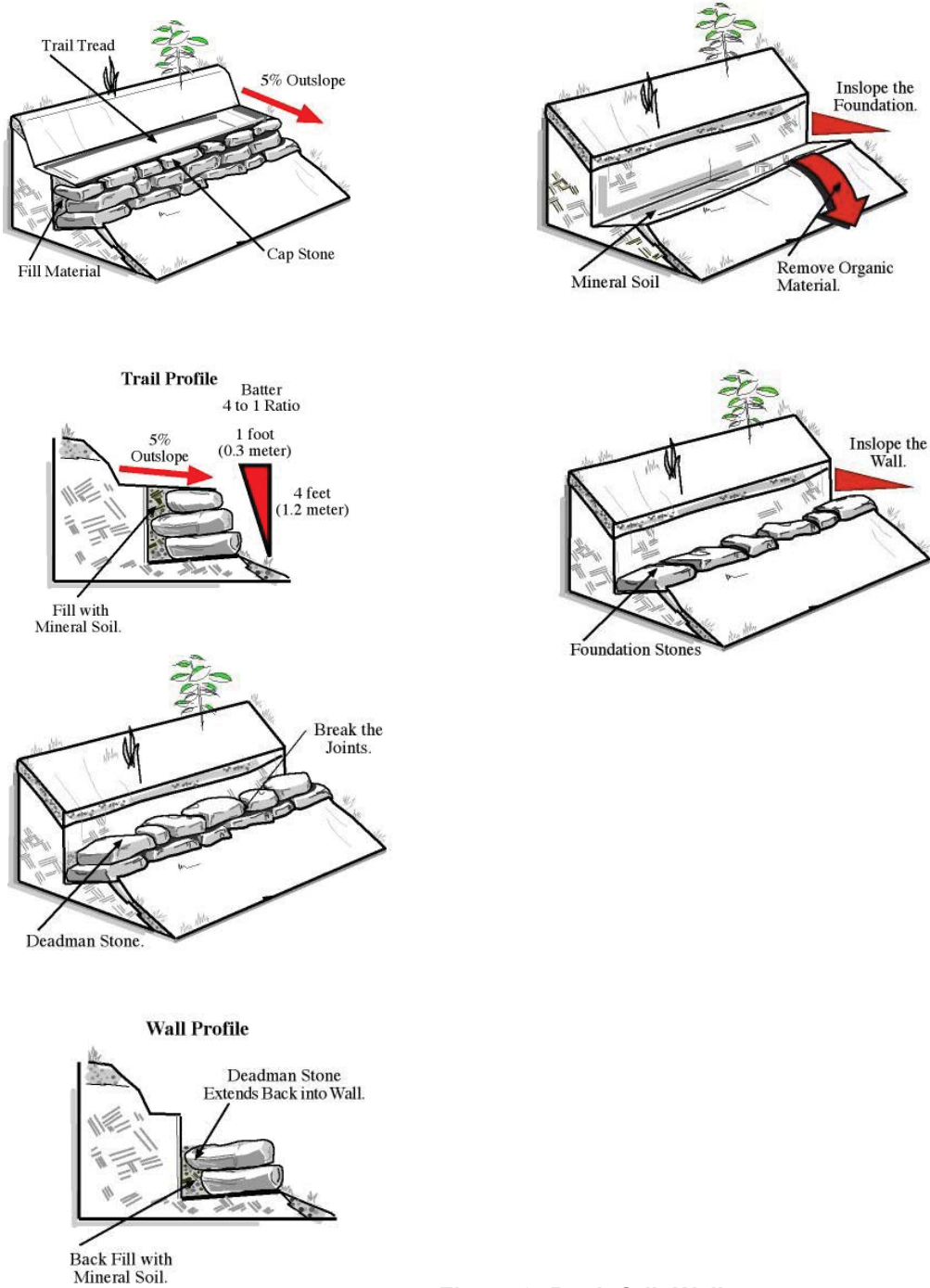

Figure 9: Rock Crib Wall

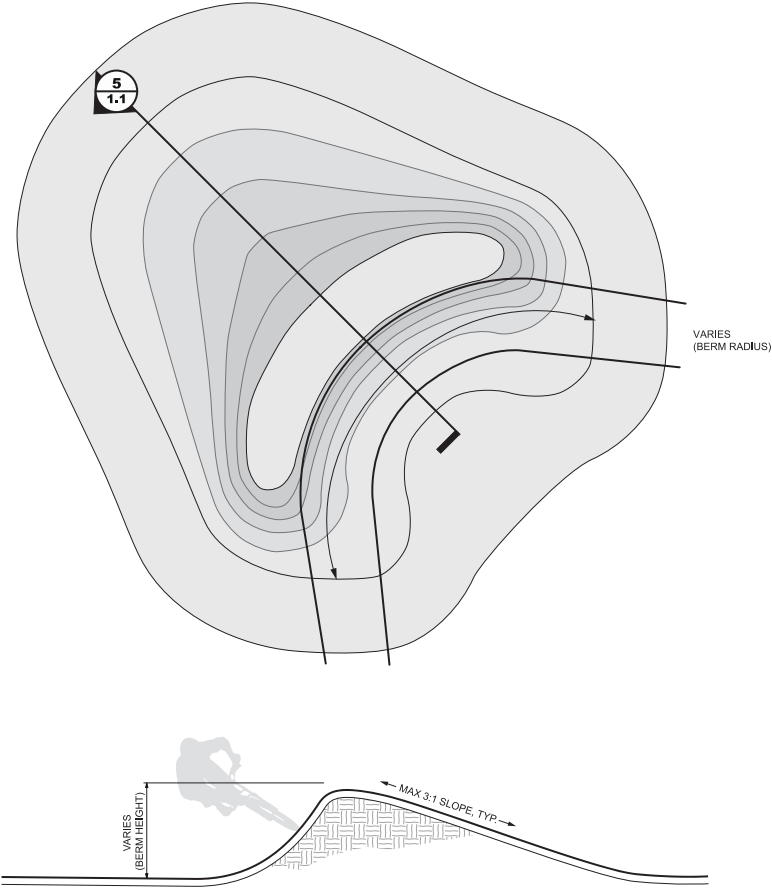

Figure 10: Berm

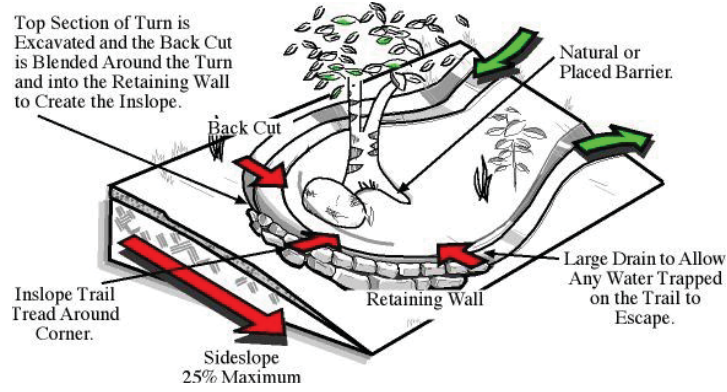
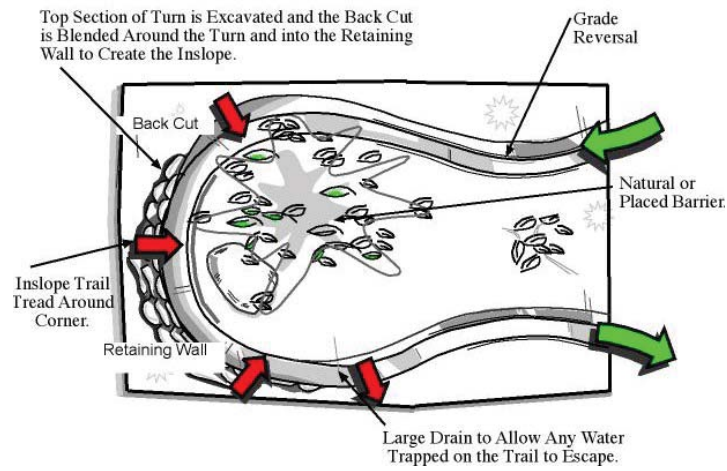

Figure 11: Insloped Switchback (Switchberm)



Figure 12: Technical Trail Feature Boardwalk (TTF)

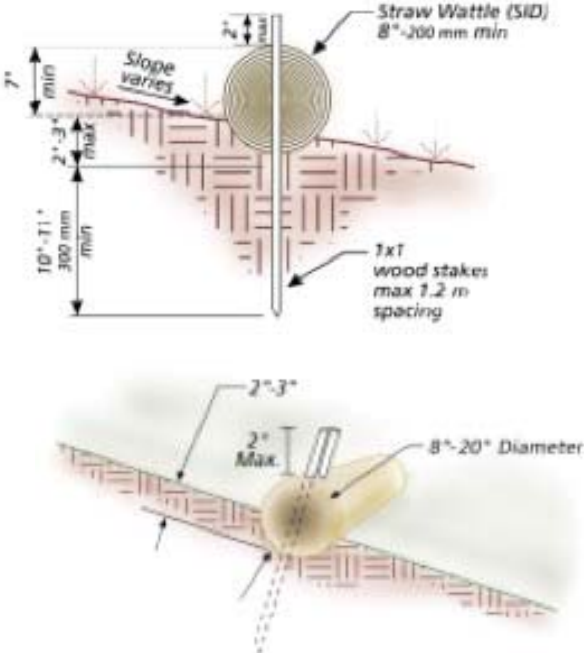

Figure 13: Coir Roll (Bio Log) Installation



Figure 14: Causeway or Turnpike Trail Construction

Trail Closure and Reclamation

Ensure smooth transition from existing trail to new trail.

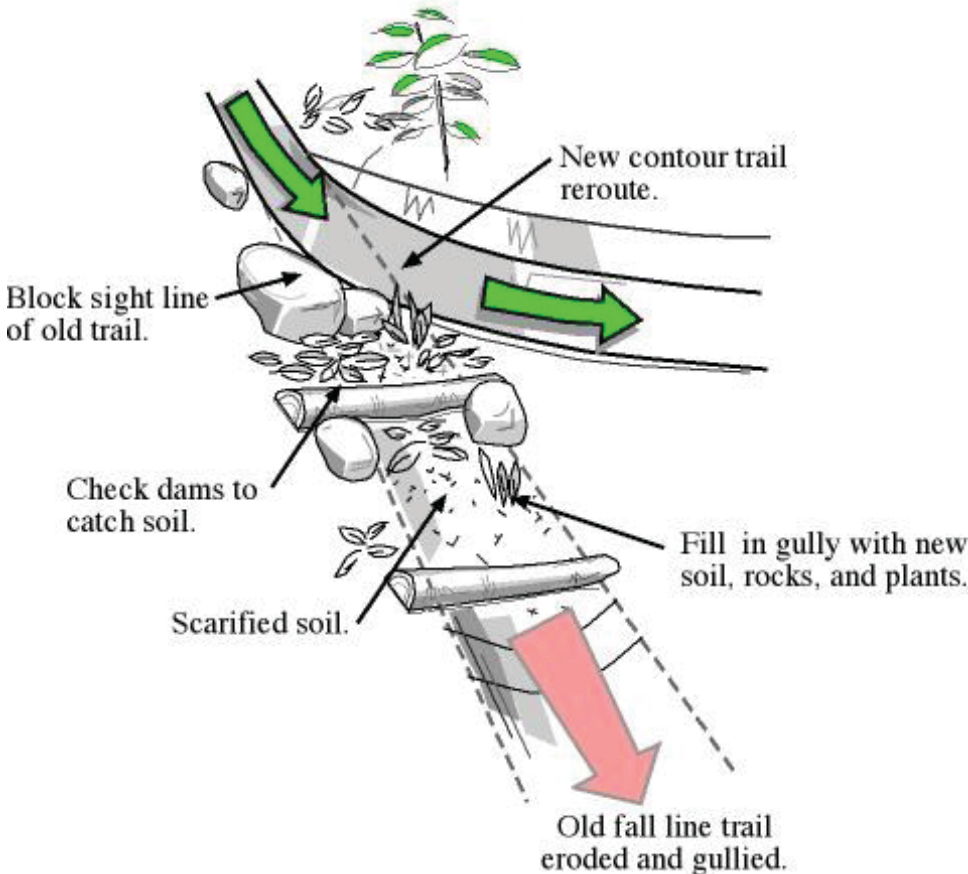

Figure 15: Trail Closure

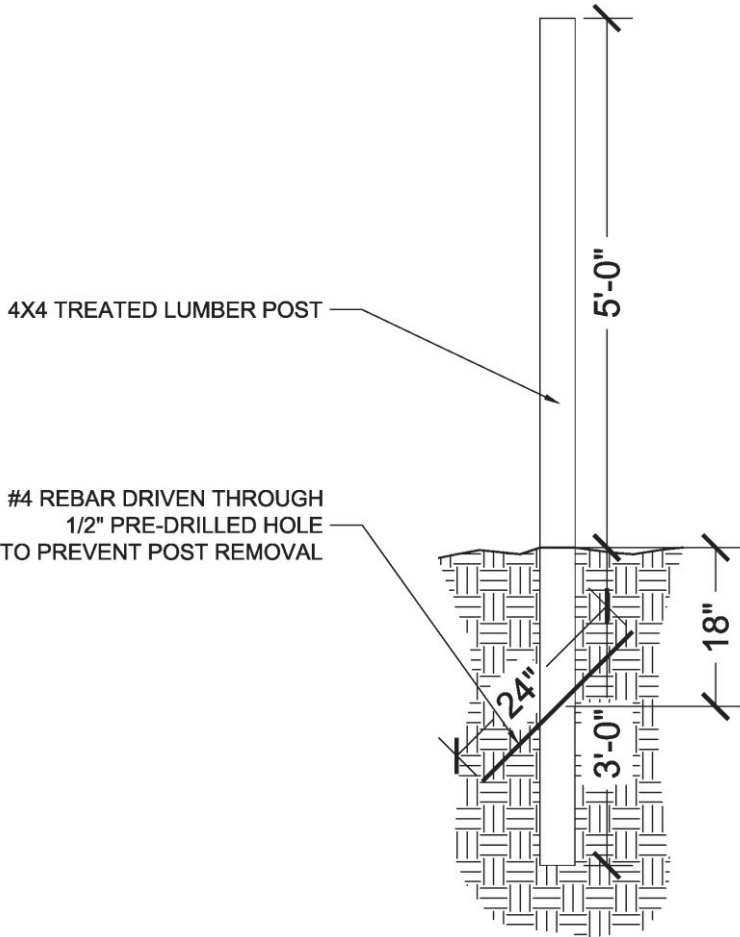

Figure 16: Map Post Installation (NTS)

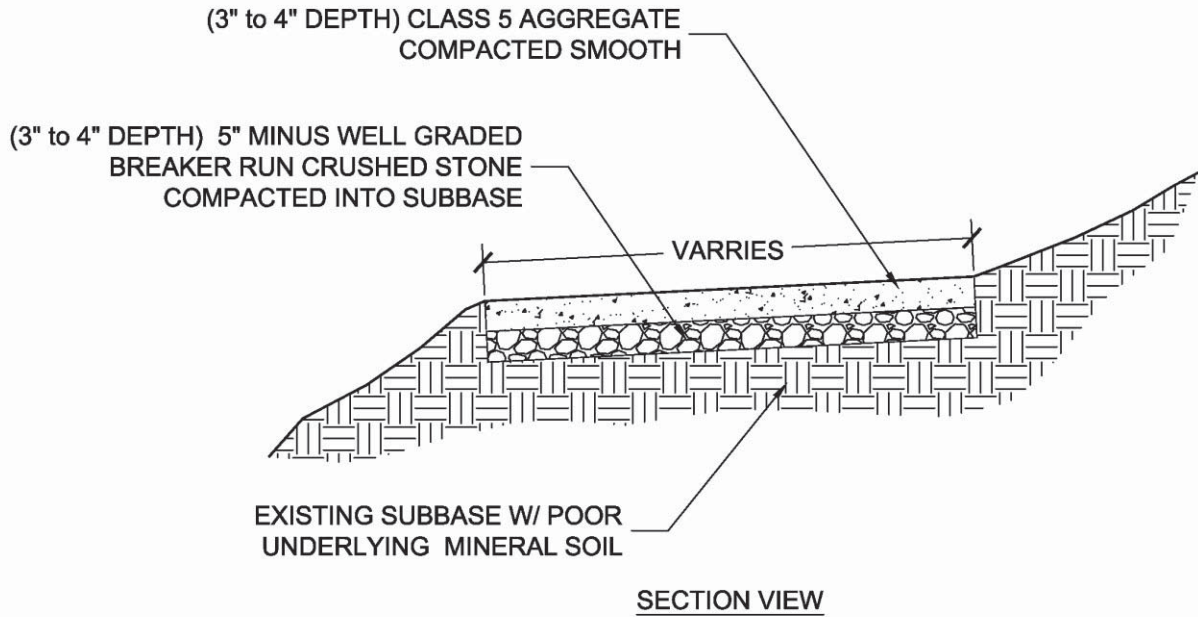

Figure 17: Trail Capping (NTS)

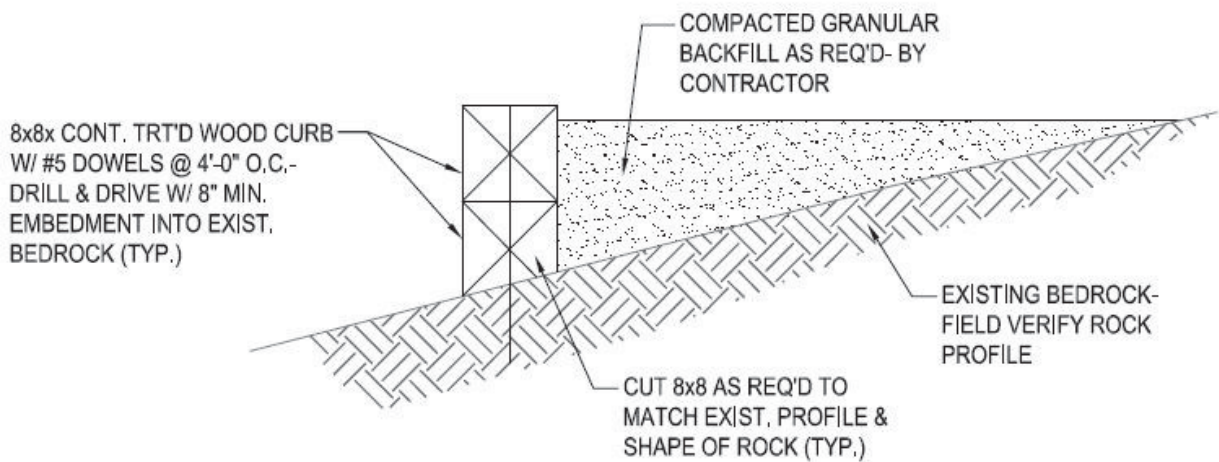

Figure 18: Wood Crib Wall (NTS)

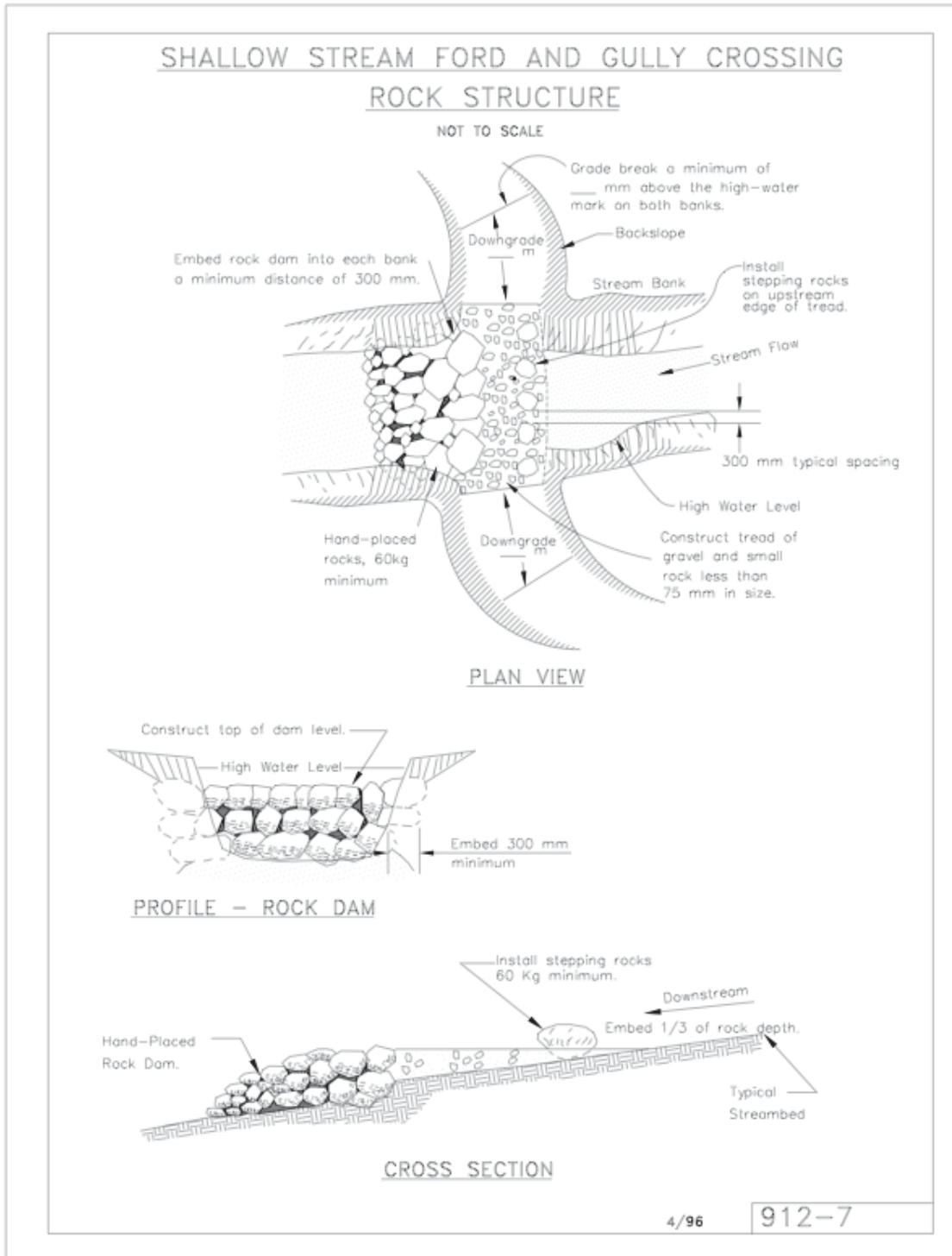

Figure 19: Shallow stream ford and gully crossing rock structure

SECTION 5: CONTRACTOR QUALIFICATIONS, REQUIREMENTS AND RESPONSIBILITIES

5.1 Professional Association

The contractor shall be a Professional Trailbuilders Association (PTBA) member in good standing. Equivalent professional experience and ability, as determined by the Club, is acceptable.

5.2 Mountain Bike-Optimized Experience

The contractor shall have demonstrable experience in building sustainable mountain bike-optimized singletrack trail in a backcountry environment. Mountain bike-optimized singletrack is that which maximizes the fun and efficiency of the bicycling experience through the provision of trail features and macro and micro design techniques.

5.3 Insurance

The contractor shall carry one and a half million dollars (\$1,500,000) in Commercial General/Umbrella Liability insurance and shall furnish a certificate listing the Club and its partner the City of Duluth as additional insureds. The certificate shall show the type, amount, class of operations covered, effective dates, and dates of expiration of policies.

5.4 Workman's Compensation

The Club reserves the right to request proof of compliance with workmen's compensation laws.

5.5 Tools

The contractor shall perform the required work using hand tools and/or small mechanized equipment that is a maximum of fifty inches (50") in width. Equipment with adjustable width tracks should be able to reduce track width to less than fifty inches (50"). Some sites may not be suitable for equipment this large and other sites may not be suitable for any mechanized equipment regardless of size due to terrain constraints. Permanent modification of trail outside the scope of work to accommodate equipment access (e.g., widening of an existing trail) is not desirable and must be specifically approved by in advance by the Club.

5.6 Mechanized Equipment Best Practices

Using mechanized equipment equipped with tracks is strongly recommended. On project work, tracks are required for heavy equipment (greater than 500 lbs. gross weight).

All equipment will be clean and free of debris before introduced to work site. Equipment is subject to inspection at the start and during the project.

All mechanized equipment shall be in good mechanical condition, free of any fluid leaks and be equipped with spark arrestors if applicable.

Each machine will be equipped with a readily accessible fully charged fire extinguisher. Heavy equipment must have two extinguishers. Mounting locations

should be chosen such that at least one fire extinguisher is accessible in the event of a rollover.

A spill kit with appropriate capacity must be mounted on the machine or available within 500 feet whenever equipment is operating.

Any equipment that does not meet these criteria shall be shut down until in compliance. If not correctable it will be removed from the project site at the request of the Club and at no additional cost to the Club.

As part of their bid package, the contractor will be asked to supply the expected list of mechanized equipment required to complete the project.

5.7 Backcountry Protocol

The Contractor's crew shall be familiar with backcountry operation and safety protocols as well as be familiar and adept at "leave no trace" practices.

When operating mechanized equipment, at least two workers will be in close proximity to provide assistance in the event of an emergency. Each worker will have a cell phone or radio with them that can be used to summon emergency service personnel. At least one GPS type device should be on hand at each worksite to help give location information to emergency dispatch personnel.

5.8 Personal Protective Equipment

It is the responsibility of the contractor to ensure that all employees working on the project equipped with and are using as appropriate the proper Personnel Protective Equipment (PPE) for the work being done. It is the contractor's responsibility that PPE be deployed where appropriate for the work being performed. The contractor must have at least one OSHA-compliant First Aid Kit readily available at each worksite.

5.9 Timetable

As part of their bid package, the Contractor will provide an approximate timetable and schedule detailing how all project work will be met.

5.10 Meetings and Progress Reviews

The contractor shall meet with the Club and designated City representative at the beginning of each work week or as otherwise agreed upon by both parties to: review progress, check completed trail and trail features against the construction documents for completeness, tabulate completed work for payment and project expectations for the upcoming week.

5.11 What Contractor Provides

The contractor shall provide the necessary supervision, equipment, materials, and tools to perform specified trail maintenance and trail construction on identified trails and sites, including fuel for any mechanized equipment/tools and any and all personal protection and safety equipment required.

5.12 Food and Water

The Contractor shall be responsible for providing food and water for self and staff.

5.13 Toilet Facilities

The contractor will be responsible for providing worksite sanitary facilities (ex. Porta-potties) for project staff or make alternate arrangements as appropriate for work areas where restroom facilities are not readily accessible.

The use of Porta-potties will be dependent on the location of the worksite relative to vehicle accessibility and concerns about potential vandalism in remote locations.

5.14 Parking

Construction personnel shall confine parking of private vehicles to within the area of the project limits or to those parking spaces available on public streets or pull off parking areas along skyline parkway and or public parking lots.

5.15 Public Safety

The Contractor shall ensure that reasonable precautions are taken to protect the public at all times where work is being performed.

5.16 Environmental Footprint

Contractor will be expected to institute practices to minimize the environmental footprint of construction activities. Examples are minimizing the running time of idle mechanized equipment, cutting treated lumber away from wetlands or standing water, clean-up of spills and trash, and staying within the designated trail corridor of 50'.

5.17 Fees for Licenses, Permits, and Insurance

All costs for required licenses and insurance shall be borne by the contractor. Permits necessary for land access and environmental permits are the responsibility of the Club and will be in place at the time of construction.

5.18 Employee/Subcontractor Conduct

All of the contractor's employees and subcontractors shall conduct themselves in a proper manner at all times. Intoxication or any unsafe behavior by the contractor's employees while performing duties related to this contract is strictly prohibited. The contractor will be required to remove from the site any individual whose continued employment or retainer is deemed to be contrary to the public interest or inconsistent with the best interests of this trail construction project, and will not use such individual to perform services under this contract.

Smoking is prohibited in City of Duluth public spaces and is not permitted at any of the project locations.

5.19 Employee Competence

The contractor may be required to immediately remove from the worksite any employee or subcontractor of the contractor who is incompetent or who endangers persons or property or whose physical or mental condition is such that it would impair

the employee's ability to satisfactorily perform the work. Notification to the contractor shall be made by voice promptly and confirmed in writing as soon as possible. No such removal shall reduce the contractor's obligation to perform all work required under this contract.

5.20 Compliance with Modern Practices

All work shall be performed and completed in a thoroughly skillful, efficient and professional manner in accordance with best modern practices, regardless of any omissions from the attached specifications and/or drawings.

5.21 Condition of Materials and Equipment

All materials and equipment incorporated into the trail shall be new or otherwise in good working order and shall comply with the applicable standard in every case where such a standard has been established for the particular type of material in question.

5.22 Disposal of Materials and Supplies Not Approved

Materials, supplies, etc., that have been delivered to the job but do not comply with specifications and have not been approved, upon notification, the contractor shall immediately remove from the premises any such condemned material, supplies, etc., and replace them with material, supplies, etc., in full accordance with the specifications.

5.23 Disposal of Materials and Supplies Not Used

Materials, supplies, etc., have been delivered to the job but are not used shall be removed from the site and properly disposed by the contractor. Tossing treated wood scraps into the surrounding landscape or placed under completed boardwalk or bridge segments is not permitted.

5.24 Access Control

The contractor is prohibited from installing gates, cables, chains, fences, and other types of barricades to limit access to the project site without prior written permission from the Club. It is anticipated that some type of access control will be necessary to control access to the trail that is under construction and is strongly encouraged. It will be up to the Contractor to determine the best access control prescription.

5.25 Use of Premises – Storage

Contractor shall confine its apparatus, storage of materials, and operation of its employees/subcontractors to limits indicated by law, ordinance, permits, and/or directions of the Club, and shall not unreasonably encumber the premises with project materials. Before any work is undertaken the contractor shall consult with the Club and secure from Club the use of such space as may be available for the storage of materials and/or equipment. Contractor will be held responsible for any damage done in connection with the use of this location for storage.

The Club is not responsible for any damages that may occur to the contractor's equipment during storage whether it is from natural causes or caused by man from such unlawful acts as theft, vandalism, and arson. The contractor is responsible for providing

their own property insurance. The contractor is responsible for providing their own storage and transportation equipment such as trailers, tarps, locks, or other security devices.

5.26 Trail Rehabilitation

The Contractor shall rehabilitate sections of trail that will be closed as a result of trail realignment. Any travel-ways or temporary access routes or trails created as a result of construction and/or ingress/egress will be restored to their original pre-existing condition.

5.27 Use of Subcontractors

The Contractor shall be able to use subcontractors to complete the work provided the subcontractors meet all qualifications and satisfy all conditions defined in this RFQ. Contractor is responsible for all actions of their subcontractor.

Subcontractor staff must be described in the bid submission. Use of subcontractors not described in the bid submission will only be allowed with written permission from the Club.

5.28 Indemnity

The contractor shall indemnify, save, and hold harmless the Club, City of Duluth,, the land owner, and their employees and agents, against any and all claims, damages, liability and court awards including costs, expenses, and attorney fees and related costs, incurred as a result of any act or omission by the contractor, or their employees, agents, subcontractors, or assignees pursuant to the terms of this contract.

5.29 Protection of Finished Construction

Contractor shall assume the responsibility for the protection of all finished construction, until at which the Club accepts in writing the work as substantially complete. The Contractor shall repair and restore any and all damage of finished work to its original state if damage occurred prior to the club accepting the trail as substantially complete.

Where responsibility can be established for damage to finished construction, the cost for repair or replacement shall be charged to the party responsible.

SECTION 6: REGULATIONS AND STANDARDS

6.1 Jurisdictional Regulation

The work shall comply with all laws, ordinances and regulations of all legally constituted authorities having jurisdiction over any part of this work. These requirements supplement the specifications and shall take precedence in case of conflict.

6.2 Davis-Bacon & Prevailing Wage

Davis-Bacon and prevailing wage requirements “do not apply” in this contract.

6.3 Applicable Laws and Courts

This solicitation and any resulting contract shall be governed in all respects by the laws of the State of Minnesota and any litigation with respect thereto shall be brought in the courts of the State.

6.4 Anti-Discrimination

By submitting their bids, bidders certify to the State that they shall conform to the provisions of the Federal Civil Rights Act of 1964, as amended, and where applicable, the Americans With Disabilities Act.

During the performance of this contract, the contractor agrees as follows:

1. The contractor will not discriminate against any employee or applicant for employment because of race, religion, color, sex, national origin, age, disability, or any other basis prohibited by state law relating to discrimination in employment, except where there is a bona fide occupational qualification reasonably necessary to the normal operation of the contractor. The contractor agrees to post in conspicuous places, available to employees and applicants for employment, notices setting forth the provisions of this nondiscrimination clause.
2. The contractor, in all solicitations or advertisements for employees placed by or on behalf of the Contractor, will state that such contractor is an equal opportunity employer.
3. Notices, advertisements and solicitations placed in accordance with federal law, rule or regulation shall be deemed sufficient for the purpose of meeting these requirements.

The contractor shall include the provisions of item 1 above in every subcontract or purchase order over ten thousand dollars (\$10,000) so that the provisions will be binding upon each subcontractor or vendor.

6.5 Ethics in Public Contracting

By submitting their bids, bidders certify that their bids are made without collusion or fraud and that they have not offered or received any kickbacks or inducements from any other bidder, supplier, manufacturer or subcontractor in connection with their bid, and that they have not conferred on any person having official responsibility for this procurement transaction any payment, loan, subscription, advance, deposit of money,

services or anything of more than nominal value, present or promised, unless consideration of substantially equal or greater value was exchanged.

SECTION 7: TIMELINE AND SCHEDULE

7.1 Project Timeline

The project schedule is as follows:

| | |
|----------------------|-------------------------------------------------------|
| various | Site visit by request (non-mandatory) |
| January 18, 2019 | Bid posting |
| February 07, 2019 | Bid opening submission deadline (end of business day) |
| February 14-15, 2019 | Anticipated award announcement |
| November 1, 2019 | Work complete |

7.2 Pre-Bid Conference and Site Visit

Due to the importance of potential contractors having a clear understanding of the specifications and requirements of this solicitation, a non-mandatory pre-bid conference/site visit will be held by contractor request and on an as needed basis. All bidders shall bring a copy of the solicitation. Any changes resulting from this conference will be noted in a written amendment to the solicitation. Failure to attend will not relieve the contractor from responsibility for estimating properly the difficulty and cost of successfully performing the work, or for proceeding to successfully perform the work without additional expense to the Club. The Club assumes no responsibility for any conclusions or interpretations made by the contractor based on information made available at the conference. Nor does the Club assume responsibility for any understanding reached or representation made by any of its representatives or agents before the execution of this contract, unless that understanding is expressly stated in this contract.

Bidders are cautioned that in no event shall failure to familiarize themselves with requirements of this solicitation, or to resolve ambiguous or inconsistent terms or conditions of this solicitation or proposed contract, constitute grounds for a claim of any kind after contract award.

As the project area occupies a large footprint, it may not be possible to visit all the trail corridors during the pre-bid conference. That does not relieve the bidder of their responsibility to be aware of the conditions over the entire site. It is expected that a worthwhile review of these sites may require at least two days.

~~The pre-bid conference/site visit will be held at~~

-
 Date: _____XXXX
 Time: _____XXXX
 Location: _____XXXX

Bidders should wear clothing suitable for hiking in the upper Midwest. The pre-bid tour should be concluded by 6pm. Bidders should bring adequate food and water for a full day on the trail.

7.3 Deadline for Requests for Clarifications/Questions

All requests for clarification must be submitted in writing to Jim Shoberg via email to jberg_21@hotmail.com and Adam Sundberg to adamsundbergdc@gmail.com

7.4 Responses to Requests for Clarifications Distributed

Response(s) to written requests for clarification will be distributed to recipients of the bid package via email only.

7.5 Bid Submission Deadline

All bid submissions are due February 07, 2019 end of business day 5:00 pm Central Time.

7.6 Anticipated Award Announcement

The contract award announcement is anticipated to occur no later than February 14-15, 2019.

7.7 Contract and Insurance Certificate

The successful bidder will be required to execute a written contract with the Club within ten (14) days after notice of acceptance of his proposal. In the event the successful bidder fails or refuses to execute a formal contract as required within ten (14) days after notice of acceptance of his bid, the Letter of Acceptance of their proposal may be revoked, and all obligations of the Club in connection herewith will be canceled.

Before work commences, an insurance certificate will be provided to the Club that fulfills the contractor's responsibilities for insurance as detailed in this document.

7.8 Work Complete

All work shall be completed and approved by the Club before November 01, 2019.

SECTION 8: BID SUBMISSION PACKAGE

8.1 Bid Submission

Each bid must be submitted via email to with the title of the email clearly marked as "**DULUTH TRAVERSE 2019 COGGS BID**" and delivered to:

Jim Shoberg jberg_21@hotmail.com &
Adam Sundberg adamsundbergdc@gmail.com

Each bid must be received prior to the deadline on the date set forth per the aforementioned schedule. Faxed bids will NOT be accepted.

It is the contractor's responsibility to verify the receipt of the email bid submission by the Club.

8.2 Submittal Checklist

The bid package must contain each of the following. Incomplete bid packages may not be considered.

- Completed bid worksheets A and B (see section 13 and attachments A and B)
- A recommended project schedule and timetable.
- Three (3) references from previous mountain bike-specific trail construction projects.
- One (1) letter of recommendation from a previous client.
- A detailed list of work accomplished from past comparable or relevant projects. The list shall include a 1-3 paragraph description of the project, client name and contact information, and dates during which the work was executed.

SECTION 9: BASIS FOR AWARD, RIGHT OF REJECTION, AND CANCELLATION

9.1 Basis for Award

The Club reserves the rights to eliminate for consideration for award any or all offers at any time prior to the award of the contract; to negotiate with bidders in the competitive range; and to award the contract to the bidders, or combination of bidders, submitting the bid determined to represent the best values.

9.2 Right of Rejection

The Club reserves the right to waive any informality in any bid, to reject any or all bids in whole or part, with or without cause, and/or to accept the proposal that in its judgment will be in the best interest of the citizens of Minnesota.

9.3 Qualifications and Experience

The qualifications and experience of the contractor in completing similar work will be given equal weight to price of the bids in determining value of qualified bids. It is considered in the best interest of the Club to allow consideration of award to other than the lowest bidder or most qualified bidder.

9.4 Additional Information

The Club reserves the right to request that the bidder supply additional information prior to the award of the contract should such action be deemed in the Clubs best interest.

9.5 Estimated Quantities

For all specifications that contain more or less quantities, it shall be understood and agreed that quantities listed in the Project Details and Worksheet B are estimated only and may be increased or decreased in accordance with the actual normal requirements of the Club and that the Club in accepting any bid or portion thereof, contracts only and agrees to purchase only the services in such quantities as represent the actual requirements of the Club.

The Club reserves the right to change the quantities at its discretion and it is understood that this will have no effect on the price per unit quoted by the bidder.

9.6 Partial Award

The Club reserves the right to award a partial award of only some of the projects contained within the solicitation or to award separate projects to separate bidders. The projects contained within this solicitation are diverse in nature and it is possible that one contractor will not be the most suitable bidder for all the projects. It is recommended to bid on all the projects, but is not required. For this reason a one-time mobilization rate is requested as a separate line item. Upon award a contractor will be allowed to bill for one mobilization regardless of the number of sub-projects included in their contract.

9.7 Right Of Cancellation

In the event a contractor is awarded more than one project, and performs that project in a manner deemed unacceptable to the Club, in the Club's sole discretion, the Club reserves the right to issue a Notice of Cancellation of remaining projects. Upon the issuance of the Notice of Cancellation, the contractor shall have fifteen (15) days to cure the deficiencies in the prior project to the Club's satisfaction. If the contractor is unwilling or unable to cure such deficiencies, the Notice of Cancellation will become effective at the end of the fifteen (15) day period, and the award of the additional projects will be deemed cancelled. In the event of a cancellation under this paragraph, both the Club and the contractor agree that each shall bear their respective costs, and the contractor shall not be entitled to any payment for the remaining projects that are the subject of the Notice of Cancellation.

SECTION 10: COMMUNICATION AND REQUEST FOR CLARIFICATIONS

10.1 Point of Contact

Questions concerning this proposal shall be via email and directed to:
Jim Shoberg jberg_21@hotmail.com &
Adam Sundberg adamsundbergdc@gmail.com
Verbal responses to questions are not binding.

10.2 Request for Clarifications

All requests for clarification shall be submitted via email to the project contact by Responses to all questions will be distributed via email to all respondents who requested a copy of the RFQ package.

10.3 Contact Protocol

Bidders SHALL NOT make any contact or communications with any member of the Evaluation Committee, or any other agent, officer, or representative of the Club or associated partners in regards to this solicitation.

10.4 Email Communication

Email communication is the primary method of receiving and responding to written requests for clarification. It is solely the bidders' responsibility to ensure that they have received all emails distributed and that any emails they have sent to the project contact have been received.

SECTION 11: FINAL INSPECTION, SUBSTANTIAL COMPLETION, RETAINAGE, WARRANTY AND PAYMENT

Upon the substantial completion of the contract work, the Club shall accompany the contractor on an inspection of the work to create a final punch list. All defects found in the work that do not meet the intent of the construction documents will be corrected before payment will be authorized.

Substantial completion is defined as the point at which the requirements of the construction documents have been met and the Club issues a letter of acceptance.

Final payment will be made upon substantial completion and approval of work per sub-project minus a 5% retainage. This retainage is held for a one year warranty period and starts on the date of substantial completion as outlined in the letter of acceptance.

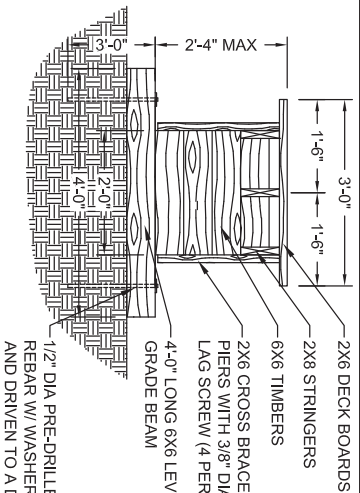

36" WIDE BOARDWALK
NOT TO SCALE

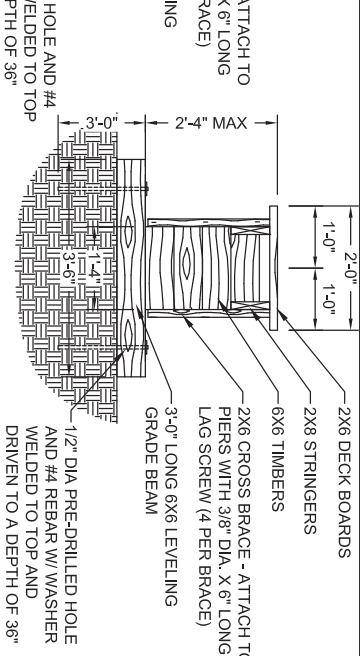

24" WIDE BOARDWALK
NOT TO SCALE

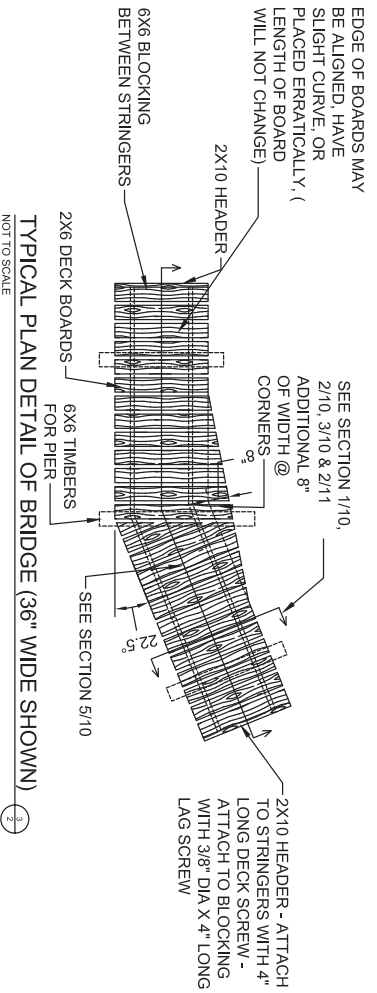

TYPICAL PLAN DETAIL OF BRIDGE (36" WIDE SHOWN)
NOT TO SCALE

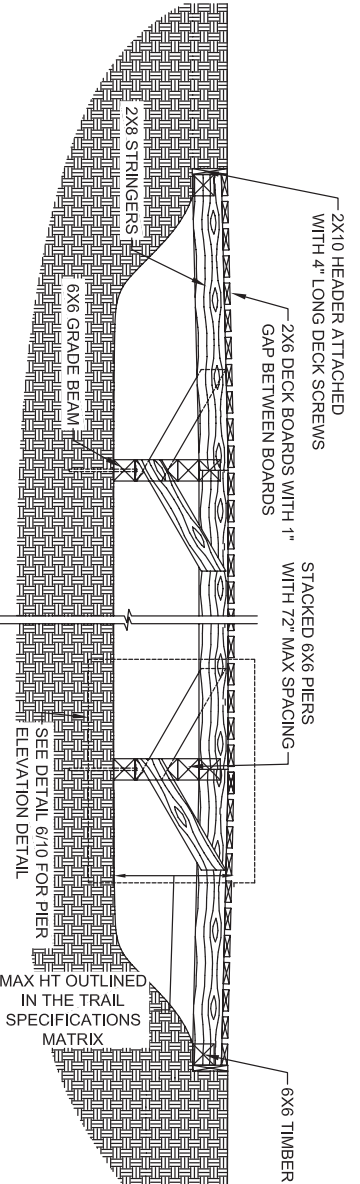

TYPICAL ELEVATION DETAIL FOR BOARDWALK (WET AREA CROSSINGS)
NOT TO SCALE

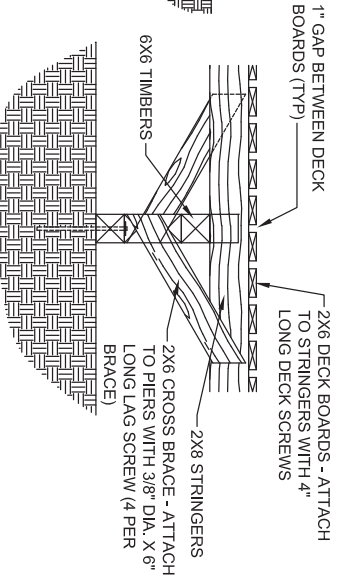

TYPICAL ELEVATION @ PIER LOCATION
NOT TO SCALE

- DETAIL NOTES:**
1. FINAL BOARDWALK FIELD DESIGN IS THE RESPONSIBILITY OF THE CONTRACTOR AND SHALL BE BASED ON THE ENGINEERED CONSTRUCTION DOCUMENTS HEREIN AND IN THE SPECIFICATIONS.
 2. CONTRACTOR IS TO PROVIDE A TYPICAL BOARDWALK AND BRIDGE SHOP DRAWING THAT IS PLANNED TO BE CONSTRUCTED IN THE FIELD FOR APPROVAL BY THE LANDSCAPE ARCHITECT.
 3. LUMBER SHALL BE SIZED TO THE FULL DIMENSIONS SHOWN ON THE PLANS, UNLESS NOTED OTHERWISE. ALL LUMBER SHALL BE A ROT-RESISTANT SPECIES OR TREATED ACCORDING TO THE OPTIONS INDICATED IN THE SPECIFICATIONS.
 4. ACCEPTABLE MATERIALS FOR THE DECK RIDING SURFACE MUST BE ROUGH CUT LUMBER AND INCLUDES: CEDAR, TAMARACK AND TREATED PINE. ALL OTHER LUMBER USED IN THE CONSTRUCTION CAN BE EITHER ROUGH CUT OR DIMENSIONAL TREATED PINE LUMBER.
 5. ROT-RESISTANT TREATMENTS OTHER THAN THOSE LISTED MUST BE APPROVED BY THE LANDSCAPE ARCHITECT PRIOR TO BIDDING.
 6. LEVELING GRADE BEAMS SHALL BE SHIMMED AS NECESSARY TO MEET DESIRED PITCH OF STRUCTURE AND ANCHORED TO THE GROUND WITH A MINIMUM OF 36" LONG #5 REBAR DRIVEN THROUGH A PRE DRILLED HOLE IN THE TIMBER.
 7. SELECT FASTENERS AND HARDWARE IN ACCORDANCE WITH THE SPECIFICATIONS
 8. SIZES, LENGTHS AND EXTENT OF ALL BOARDWALKS, ROCK HARDENED TREAD, BRIDGES AND BERM TO BE FIELD FIT AT TIME OF CONSTRUCTION.
 9. BOARDWALK & BRIDGE CONSTRUCTION LOCATIONS WILL BE DETERMINED IN THE FIELD BY THE CONTRACTOR AND SUBMITTED TO THE OWNER FOR APPROVAL.
 10. CUT BRUSH AND SLASH MUST BE DISPOSED IN AN UPLAND LOCATION AND MUST BE KEPT OUT OF STREAMS, GULLES, SWALES, WET AREAS, AND LOW AREAS. SEE SPECIFICATIONS FOR DETAILS.
 11. NO EXCAVATION OR FILL PERMITTED IN WET AREAS. IT IS THE RESPONSIBILITY OF THE CONTRACTOR TO CONSULT WITH THE OWNER PRIOR TO DOING ANY WORK WITHIN SUSPECTED WET AREAS.
 12. WOOD RAMPS OR STONE PITCHING MAY BE REQUIRED BEFORE AND AFTER BRIDGES AND BOARDWALKS. APPLICATION WILL BE DETERMINED IN THE FIELD. BY THE CONTRACTOR AND MUST BE APPROVED BY THE OWNER PRIOR TO CONSTRUCTION. PAYMENT FOR RAMPS WILL BE ADDED TO THE TOTAL LENGTH OF THE BOARDWALK AND PAYMENT FOR STONE PITCHING WILL BE PER THE UNIT BID PRICE OF ROCK ARMORING.

- DETAIL NOTES:**
1. FINAL BOARDWALK FIELD DESIGN IS THE RESPONSIBILITY OF THE CONTRACTOR AND SHALL BE BASE ON THE ENGINEERED CONSTRUCTION DOCUMENTS HEREIN AND IN THE SPECIFICATIONS.
 2. CONTRACTOR IS TO PROVIDE A TYPICAL BOARDWALK AND BRIDGE SHOP DRAWING THAT IS PLANNED TO BE CONSTRUCTED IN THE FIELD FOR APPROVAL BY THE LANDSCAPE ARCHITECT.
 3. LUMBER SHALL BE SIZED TO THE FULL DIMENSIONS SHOWN ON THE PLANS UNLESS NOTED OTHERWISE. ALL LUMBER SHALL BE A ROT-RESISTANT SPECIES OR TREATED ACCORDING TO THE OPTIONS INDICATED IN THE SPECIFICATIONS.
 4. ACCEPTABLE MATERIALS FOR THE DECK RIDING SURFACE MUST BE ROUGH LUMBER AND NOT SMOOTH. ALL LUMBER SHALL BE TREATED PINE. LUMBER WHEN TREATED IN THE PACK AND NOT TREATED PINE, CAN BE EITHER ROUGH CUT OR DIMENSIONAL TREATED PINE LUMBER.
 5. ROT-RESISTANT TREATMENTS OTHER THAN THOSE LISTED MUST BE APPROVED BY THE LANDSCAPE ARCHITECT PRIOR TO BIDDING.
 6. LEVELING GRADE BEAMS SHALL BE SHIMMED AS NECESSARY TO MEET DESIRED PITCH OF STRUCTURE AND ANCHORED TO THE GROUND WITH A MINIMUM OF 3/8" LONG #6 REBAR DRIVEN THROUGH A PRE DRILLED HOLE IN THE TIMBER.
 7. SELECT FASTENERS AND HARDWARE IN ACCORDANCE WITH THE SPECIFICATIONS
 8. SIZES, LENGTHS AND EXTENT OF ALL BOARDWALKS, ROCK HARDENED TREAD, BRIDGES AND BERMS TO BE FIELD FIT AT TIME OF CONSTRUCTION.
 9. BOARDWALK & BRIDGE CONSTRUCTION LOCATIONS WILL BE DETERMINED IN THE FIELD BY THE CONTRACTOR AND SUBMITTED TO THE OWNER FOR APPROVAL.
 10. CUT BRUSH AND SLASH MUST BE DISPOSED IN AN UPLAND LOCATION AND MUST BE KEPT OUT OF STREAMS, GULLES, SWALES, WET AREAS, AND LOW AREAS. SEE SPECIFICATIONS FOR DETAILS.
 11. NO EXCAVATION OR FILL PERMITTED IN WET AREAS. IT IS THE RESPONSIBILITY OF THE CONTRACTOR TO CONSULT WITH THE OWNER PRIOR TO DOING ANY WORK WITHIN SUSPECTED WET AREAS.
 12. WOOD RAMPS OR STONE PITCHING MAY BE REQUIRED BEFORE AND AFTER BRIDGES AND BOARDWALKS. APPLICATION WILL BE DETERMINED IN THE FIELD. BY THE CONTRACTOR AND MUST BE APPROVED BY THE OWNER PRIOR TO CONSTRUCTION. PAYMENT FOR RAMPS WILL BE ADDED TO THE TOTAL LENGTH OF THE BOARDWALK AND PAYMENT FOR STONE PITCHING WILL BE PER THE UNIT BID PRICE OF ROCK ARMORING.

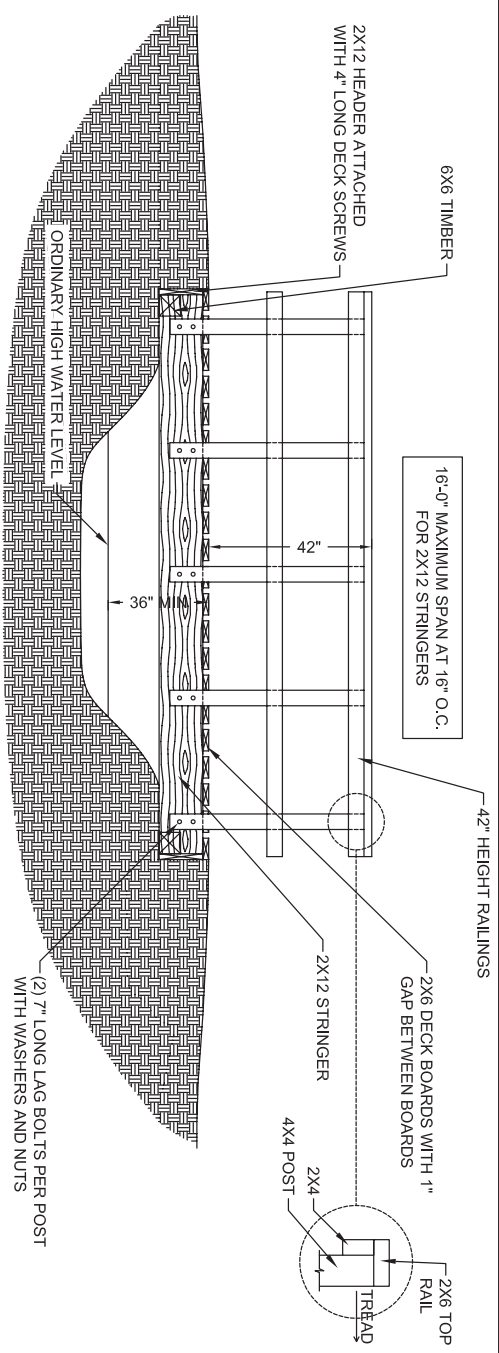

TYPICAL ELEVATION DETAIL FOR BRIDGE (CREEK CROSSINGS)
NOT TO SCALE

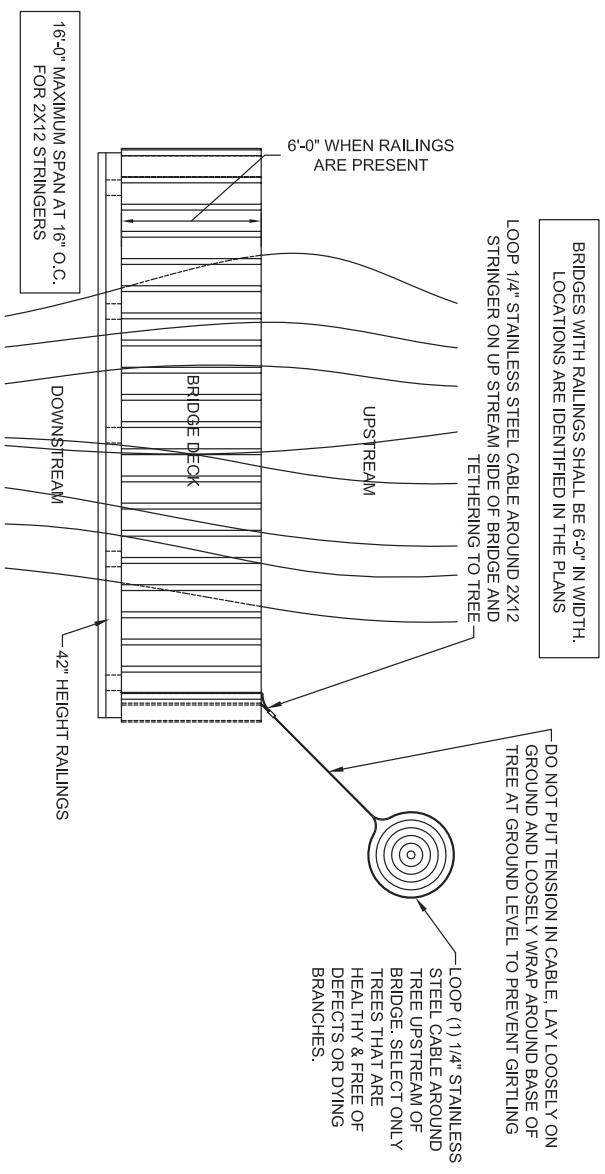

TYPICAL PLAN DETAIL FOR BRIDGE (CREEK CROSSINGS)
NOT TO SCALE

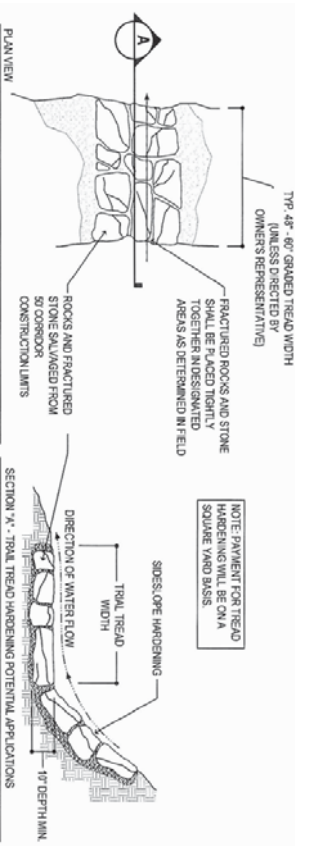

CONSTRUCTION NOTE:

BACKFILL BEDDING MATERIAL SHALL BE 3\"/>

TRAIL TREAD ROCK ARMORING AND SIDESLOPE ARMORING DETAIL
NOT TO SCALE

1

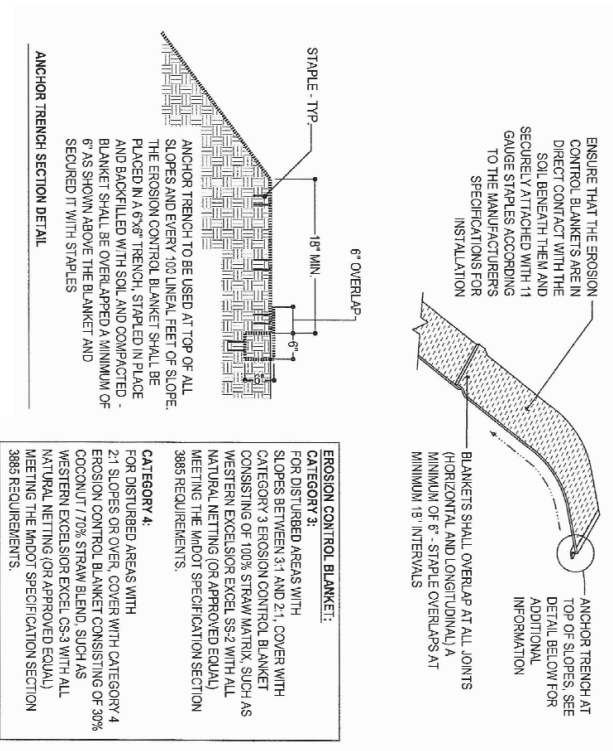

EROSION CONTROL BLANKET:

CATEGORY 3: FOR DISTURBED AREAS WITH SLOPES BETWEEN 3:1 AND 2:1, COVER WITH CATEGORY 3 EROSION CONTROL BLANKET CONSISTING OF 100% STRAW MATRIX, SUCH AS WESTERN EXCEL SORS EXCEL SS2 WITH ALL NATURAL NETTING (OR APPROVED EQUAL) MEETING THE MDOT SPECIFICATION SECTION 3885 REQUIREMENTS.

CATEGORY 4: FOR DISTURBED AREAS WITH 2:1 SLOPES OR OVER, COVER WITH CATEGORY 4 EROSION CONTROL BLANKET CONSISTING OF 30% COCOONUT / 70% STRAW BLEND, SUCH AS WESTERN EXCEL SORS EXCEL CS3 WITH ALL NATURAL NETTING (OR APPROVED EQUAL) MEETING THE MDOT SPECIFICATION SECTION 3885 REQUIREMENTS.

WOOD FIBER BLANKET DETAIL
NOT TO SCALE

2

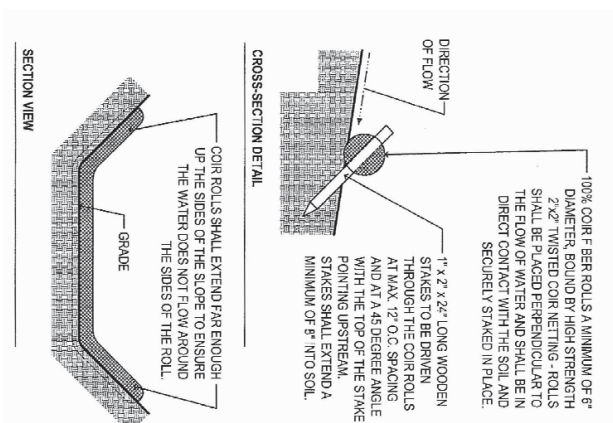

CROSS-SECTION DETAIL

100% COIR FIBER ROLLS A MINIMUM OF 6\"/>

COIR ROLL DETAIL
NOT TO SCALE

3

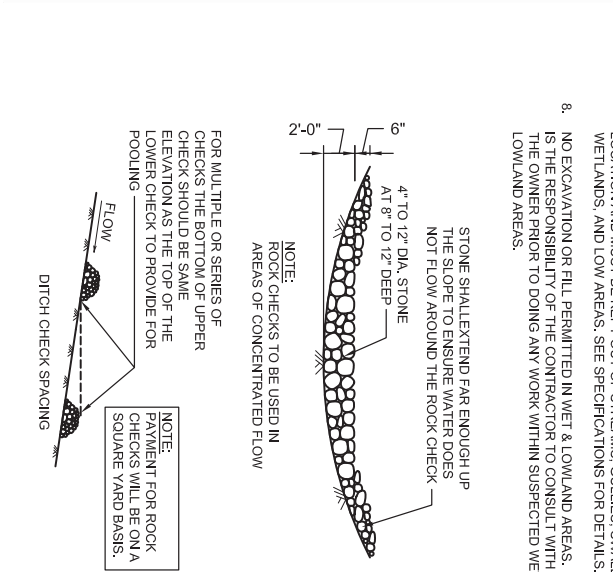

NOTE: ROCK CHECKS TO BE USED IN AREAS OF CONCENTRATED FLOW

STONE SHALL EXTEND FAR ENOUGH UP THE SLOPE TO ENSURE WATER DOES NOT FLOW AROUND THE ROCK CHECK

FOR MULTIPLE OR SERIES OF CHECKS THE BOTTOM OF UPPER CHECK SHOULD BE SAME ELEVATION AS THE TOP OF THE LOWER CHECK TO PROVIDE FOR POOLING

NOTE: PAYMENT FOR ROCK CHECKS WILL BE ON A SQUARE YARD BASIS.

ROCK CHECK DETAIL
NOT TO SCALE

4

- SWPPP NOTES:**
1. ALL DISTURBED AREAS NOT PART OF ACTIVE TREAD TO BE STABILIZED WITHIN 7 DAYS OF NOT BEING WORKED. SEE (SWPPP) STORM WATER POLLUTION PREVENTION PLAN FOR DETAILS.
 2. WHENEVER POSSIBLE USE NATIVE DUFF MATERIALS FOUND IN THE TRAIL CORRIDOR AS A MULCH FOR COVERING SOIL EXPOSED BY BACKSLOPE AND DOWNSLOPE CUTS. WOOD CHIPS MADE FROM WOODY MATERIAL CLEARED AS A RESULT OF THE CORRIDOR CLEARING ARE AN ACCEPTABLE ALTERNATIVE TO NATIVE DUFF MULCH.
 3. FOR SLOPE ANGLES UNDER 3:1 USE TEMPORARY EROSION CONTROL SEED MIX AND FOR DISTURBED AREAS THAT ARE LACKING ADEQUATE NATIVE DUFF MATERIAL.
 4. FOR SLOPE ANGLES 3:1 AND OVER USE PERMANENT EROSION CONTROL SEED MIX AND EROSION CONTROL BLANKET FOR LAND SLIDE AREAS AND AREAS OF HEAVY DISTURBANCE. THESE AREAS MUST BE APPROVED BY THE OWNER.
 5. SEE SWPPP FOR SEED MIX DETAILS.
 6. AFTER COMPLETION OF ALL GRADING, THE TRAIL TREAD SHALL BE MECHANICALLY COMPACTED TO ITS SPECIFIED WIDTH USING A VIBRATORY PLATE, SHEEPS FOOT, OR OTHER APPROVED EQUAL COMPACTOR.
 7. CUT BRUSH AND SLASH MUST BE DISPOSED IN AN UPLAND LOCATION AND MUST BE KEPT OUT OF STREAMS, GULLIES, SWALES, WETLANDS, AND LOW AREAS. SEE SPECIFICATIONS FOR DETAILS.
 8. NO EXCAVATION OR FILL PERMITTED IN WET & LOWLAND AREAS. IT IS THE RESPONSIBILITY OF THE CONTRACTOR TO CONSULT WITH THE OWNER PRIOR TO DOING ANY WORK WITHIN SUSPECTED WET & LOWLAND AREAS.

EXHIBIT D

City of Duluth Incident/Injury Report

Supervisor to complete within 24 hours of incident/injury. If injury required treatment by a medical provider, attach medical documentation. Completed forms should be emailed to accidentreporting@duluthmn.gov.

| | | |
|-----------------------------------------------------------------------------------------------------------------------------------------------------------------------------------------------------------|------------------------------------------------------------------------------------------------------------------------------|--------------------------------------------|
| Date of incident/injury: | <input type="checkbox"/> Employee <input type="checkbox"/> Non-Employee | Department/Division: |
| Choose one that best describes this claim: <input type="checkbox"/> Incident only, no medical care <input type="checkbox"/> Medical only, no lost time <input type="checkbox"/> Injury includes lost time | | |
| Initial treatment sought: | <input type="checkbox"/> Hospital ER <input type="checkbox"/> Clinic <input type="checkbox"/> Refused to see MD / None | Doctor/clinic name, address, phone number: |

| | | | | |
|---------------|-------------|-----------------------------------------------------------------------|--------|----------------|
| Last name: | First name: | MI: | SSN: | |
| Address: | | | | |
| City: | State: | Zip code: | Phone: | Date of birth: |
| Date of hire: | Occupation: | Gender: <input type="checkbox"/> Male <input type="checkbox"/> Female | | |

| | |
|--------------------------------------------------------------------------------------------------------------------------|--------------------------------------------------|
| Did accident, injury, or incident occur on employer's premises? <input type="checkbox"/> Yes <input type="checkbox"/> No | Name and address of the place of the occurrence: |
|--------------------------------------------------------------------------------------------------------------------------|--------------------------------------------------|

| | | |
|---------------------------------------------------------------------------------------------|----------------------------------------------------------------------------------------------------------|--------------------------------------------------------------------------------------------------------------|
| Time employee began work: _____ <input type="checkbox"/> a.m. <input type="checkbox"/> p.m. | Time of accident, injury, or incident: _____ <input type="checkbox"/> a.m. <input type="checkbox"/> p.m. | |
| Date employer notified of accident, injury, or incident: _____ | Date employer notified of lost time: _____ | |
| First date of any lost time: _____ | Return to work date: _____ | RTW with restrictions: <input type="checkbox"/> Yes <input type="checkbox"/> No <input type="checkbox"/> N/A |

Describe the nature of the accident, injury, or incident. Be specific. Include body parts affected.

Describe the activities when the accident, injury, or incident occurred with details of how it happened.

What tools, equipment, machines, objects and/or substances were involved?

| | | |
|--------------------------------------------------------------------------------------------|---------------------------------|------------------------------|
| Incident investigation conducted: <input type="checkbox"/> Yes <input type="checkbox"/> No | Date supervisor notified: _____ | Date report completed: _____ |
| Supervisor name: _____ | Supervisor phone number: _____ | |

Names and phone numbers of witnesses:

Incident was a result of: safety violation machine malfunction product defect motor vehicle accident N/A

Supervisor comments:

What actions have been taken to prevent recurrence?

City of Duluth Incident/Injury Report

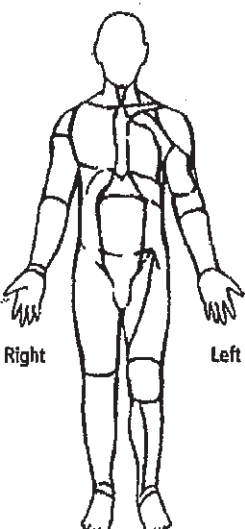
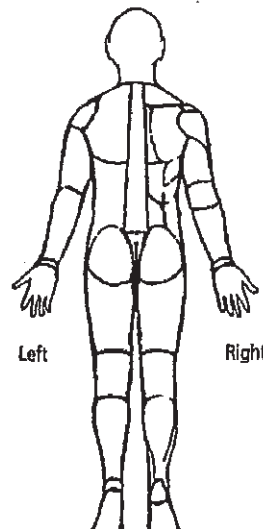
| | |
|-------------------------------------------------------------------------------------------------------------------------------------------------------------------------------------------------------------------------------------------------------------------------------------------------------------------------------------------------------------------------------------------------------------------------------------------------------------------------------------------------------------------------------------------------------------------------------------------------------------------------------------------------------------------------------------------------------------------------------------------------------------------------------------------------------------------------------------------------------------------------------------------------------------------------------------------------------------------------------------------------------|---------------------------------------------------------------------------------------------------------------------------------------------------------------------------------------------------------------------------------------------------------------------------------------------------------------------------------------------------------------------------------------------------------------------------------------------------------------------------------------------------------------------------------------------------|
| <p>CAUSE</p> <p><input type="checkbox"/> Slip and fall</p> <p><input type="checkbox"/> Struck by equipment</p> <p><input type="checkbox"/> Lifting or moving</p> <p><input type="checkbox"/> Caught (in, on, or between)</p> <p><input type="checkbox"/> Needle puncture</p> <p><input type="checkbox"/> Object in eye (<input type="checkbox"/> Right <input type="checkbox"/> Left)</p> <p><input type="checkbox"/> Repetitive/overuse</p> <p><input type="checkbox"/> Other (specify): _____</p> <p>TYPE OF INJURY</p> <p><input type="checkbox"/> Scrape/bruise</p> <p><input type="checkbox"/> Sprain/strain</p> <p><input type="checkbox"/> Puncture wound</p> <p><input type="checkbox"/> Cut/laceration</p> <p><input type="checkbox"/> Concussion</p> <p><input type="checkbox"/> Bite</p> <p><input type="checkbox"/> Chemical burn/rash/breathing difficulties</p> <p><input type="checkbox"/> No apparent injury</p> <p><input type="checkbox"/> Other (specify): _____</p> | <p style="text-align: center;">MARK AREAS OF INJURY BELOW:</p> <p style="text-align: center;">Areas can be marked by typing an "X" in the text box wherever needed.</p> <div style="display: flex; justify-content: space-around;"> <div style="text-align: center;"> <p>Front</p>  </div> <div style="text-align: center;"> <p>Back</p>  </div> </div> |
|-------------------------------------------------------------------------------------------------------------------------------------------------------------------------------------------------------------------------------------------------------------------------------------------------------------------------------------------------------------------------------------------------------------------------------------------------------------------------------------------------------------------------------------------------------------------------------------------------------------------------------------------------------------------------------------------------------------------------------------------------------------------------------------------------------------------------------------------------------------------------------------------------------------------------------------------------------------------------------------------------------|---------------------------------------------------------------------------------------------------------------------------------------------------------------------------------------------------------------------------------------------------------------------------------------------------------------------------------------------------------------------------------------------------------------------------------------------------------------------------------------------------------------------------------------------------|

| COMPLETE FOR VEHICLE, EQUIPMENT, OR PROPERTY DAMAGE | | | |
|----------------------------------------------------------------------------------------------------------------------------------------------------------------------------------------------------------------------------------------|----------------------------------------------------------------|-------------------------------------------------------------------------------------|-----------------------------------------------------------------------------------------------------------------|
| <p>For vehicle accidents: Attach sketch and additional information of how vehicle accident occurred.</p> <p>Include street names, direction of travel, locations of vehicles, objects and traffic control devices (↑ North)</p> | | | |
| Incident Location: _____ | | Time of incident: _____ <input type="checkbox"/> a.m. <input type="checkbox"/> p.m. | |
| Police called: <input type="checkbox"/> Yes <input type="checkbox"/> No | | Police Traffic Accident Report ICR #: _____ | |
| City vehicle, property, or equipment involved | Description: _____ | | |
| | Vehicle #: _____ | Make/Model: _____ | Year: _____ |
| | Describe damage: _____ | | |
| Non-city vehicle, property, or equipment involved | Owner full name: _____ | | <input type="checkbox"/> Driver <input type="checkbox"/> Passenger <input type="checkbox"/> Other |
| | Owner address: _____ | | |
| | Owner phone number: _____ | | Vehicle license #: _____ |
| | Make/Model: _____ | Color: _____ | Year: _____ |
| | Describe damage: _____ | | |
| Weather conditions: | Roadway conditions: | Light conditions: | Approximate temperature: _____ °F |
| <input type="checkbox"/> Clear <input type="checkbox"/> Wind | <input type="checkbox"/> Dry <input type="checkbox"/> Mud | <input type="checkbox"/> Night | Estimated speed: _____ mph |
| <input type="checkbox"/> Rain <input type="checkbox"/> Cloudy | <input type="checkbox"/> Wet <input type="checkbox"/> Paved | <input type="checkbox"/> Day | Vehicle: <input type="checkbox"/> Loaded <input type="checkbox"/> Empty |
| <input type="checkbox"/> Fog <input type="checkbox"/> Sleet | <input type="checkbox"/> Snow <input type="checkbox"/> Unpaved | <input type="checkbox"/> Good | What was load: _____ |
| <input type="checkbox"/> Snow | <input type="checkbox"/> Ice | <input type="checkbox"/> Poor | Drug and/or alcohol test? <input type="checkbox"/> Yes <input type="checkbox"/> No <input type="checkbox"/> N/A |

The Incident/Injury Form should be printed and signed by supervisor and employee. Completed forms can be scanned to accidentreporting@duluthmn.gov.

Supervisor Signature: _____

Date: _____

Employee Signature: _____

Date: _____